

19579

(DE)	MONTAGEANLEITUNG:	DREHTÜR 1-TLG. + SEITENWAND IN FLUCHT + SEITENWAND IM WINKEL
(GB)	INSTALLATION INSTRUCTIONS	HINGED DOOR + IN LINE FIXED PANEL + FIXED PANEL IN 90°
(FR)	NOTICE DE MONTAGE	PORTE PIVOTANTE + PAROI FIXE EN LIGNE + PAROI FIXE À 90°
(CZ)	NÁVOD K MONTÁŽI:	OTOČNÉ DVEŘE + BOČNÍ STĚNA V ROVINĚ + BOČNÍ STĚNA 90°
(PL)	INSTRUKCJA MONTAŻU:	DRZWI OBROTOWE + ŚCIANKA BOCZNA W LINIE + ŚCIANKA BOCZNA 90°
(SK)	NÁVOD NA MONTÁŽ:	JEDNOKRÍDLOVÉ DVEŘE + PEVNÁ STĚNA + BOČNÁ STĚNA 90°
(NL)	MONTAGE INSTRUCTIE:	DRAAIDEUR MET VASTE WAND IN LIJN + VASTE WAND
(SW)	MONTERINGSINSTRUKTION:	SVÅNGDÖRR MED JUSTERBART PARTI + FAST PARTI I VINKEL
(RO)	INSTRUCȚIUNI DE MONTAJ:	UȘĂ PIVOTANTĂ DINTR-O BUCATĂ + PARTE FIXĂ ÎN CONTINUARE+ PERETE LATERAL PE COLȚ
(DK)	MONTERINGS ANVISNING:	SVINGDØR I LINJE X FAST VEGG
(UA)	ІНСТРУКЦІЯ З МОНТАЖУ:	ПОВОРОТНІ ДВЕРІ З ПАНЕЛЮ В ОДНІЙ ЛІНІЇ + ФІКСОВАНА ПАНЕЛЬ
(NO)	MONTERINGS ANVISNING:	SVINGDØR I LINJE X FAST VEGG

1. - 13.



14. - 22.









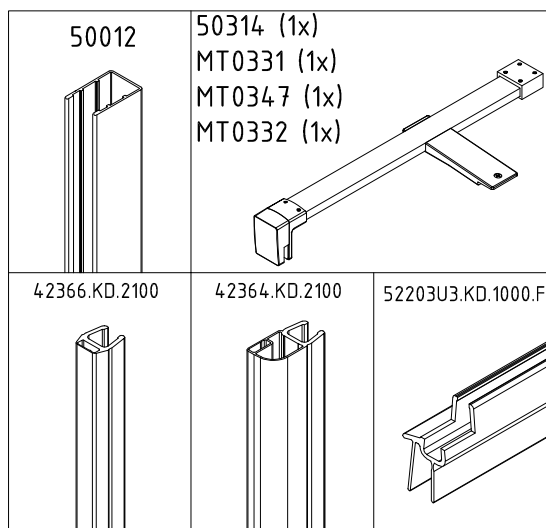
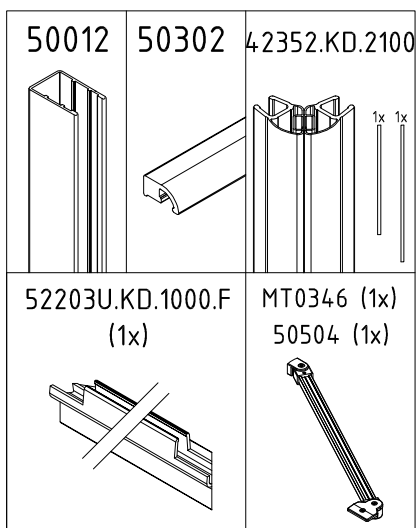
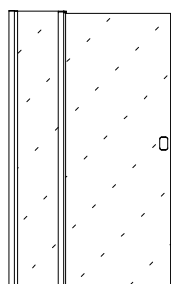
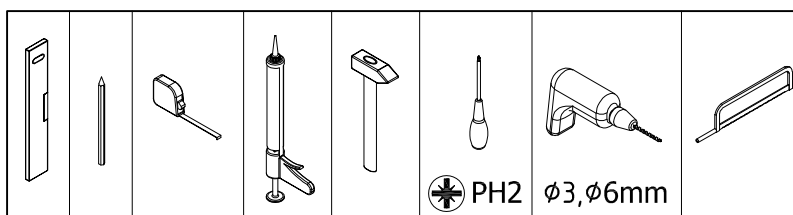



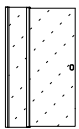

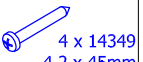





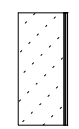

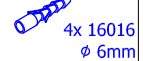

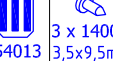

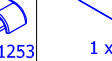

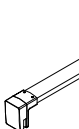
Benötigtes Werkzeug:
Necessary tools:
Outil Nécessaire:
Nářadí potřebné pro montáž:
Potrzebne narzędzia:
Potrebne náradie:
Benodigde gereedschappen:
Nödvändiga verktyg:
Instrumente necesare:
Følgende verktøy:
Необхідні інструменти:
Følgende verktøy:

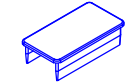
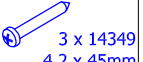

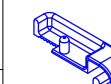
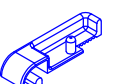
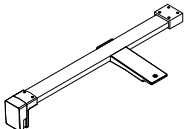
1x

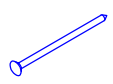

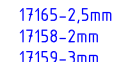
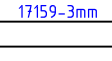
Zubehör:
 Equipment:
 Accessoires:
 Příslušenství:
 Dodatki:
 Príslušenstvo:
 Accessoires:
 Tillbehör:
 Accesorii:
 Tilbehør:
 Аксессуары:
 Tilbehør:

	 1 x 11221	 1 x 51339	 4 x 14349 4,2 x 45mm	 3x51381	 1 x 51348	 1 x 51272	 1 x 51273	 1 x MT0345
	 1 x 14041 3mm	 1 x 51399	 4x 16016 Ø 6mm	 3x51338	 54013	 3 x 14003 3,5x9,5mm	 1 x 51254	 1 x 51253
	 1 x 51339	 1 x 51399	 3 x 14349 4,2 x 45mm	 3x51381	 3x51338	 1 x 51274	 1 x 51275	
 1 x 14139 4,2 x 50mm	 1 x 16016 Ø 6mm	 1 x 11221	 17165-2,5mm	 17158-2mm	 17159-3mm	 1x51422		

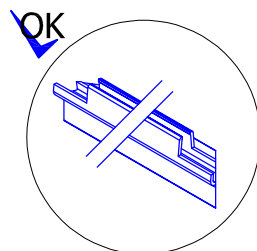
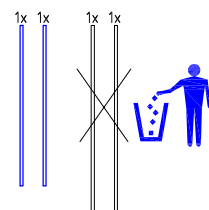
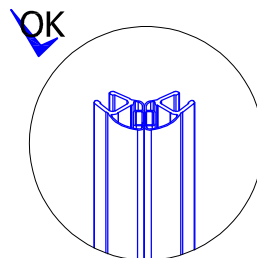
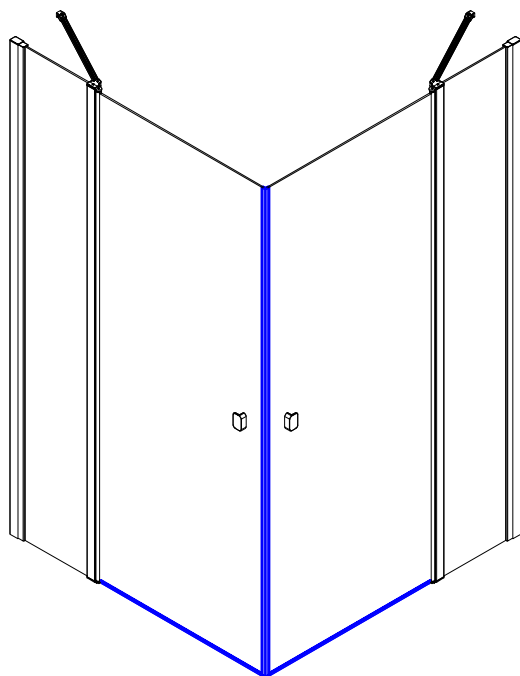
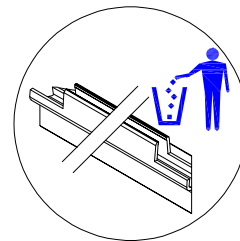
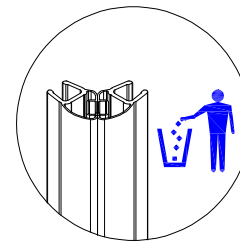
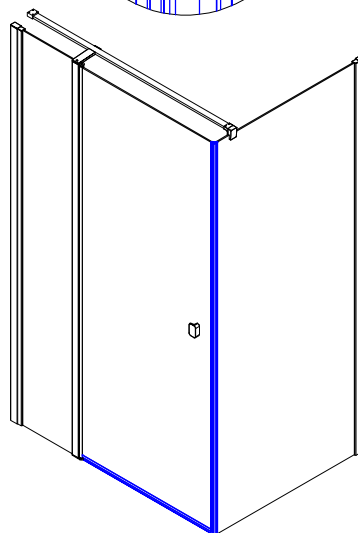
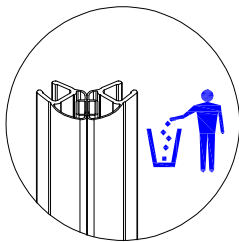
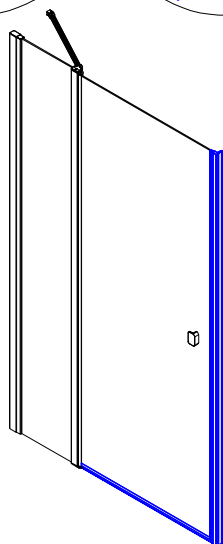
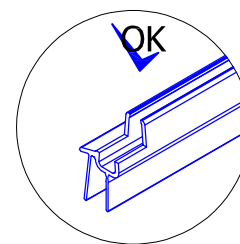
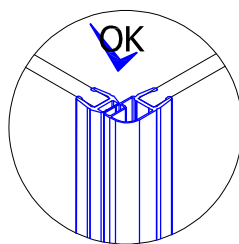
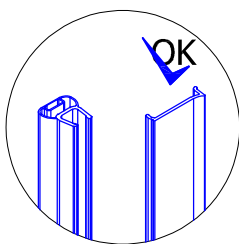
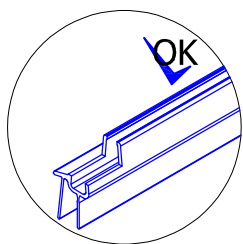
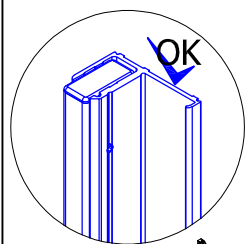

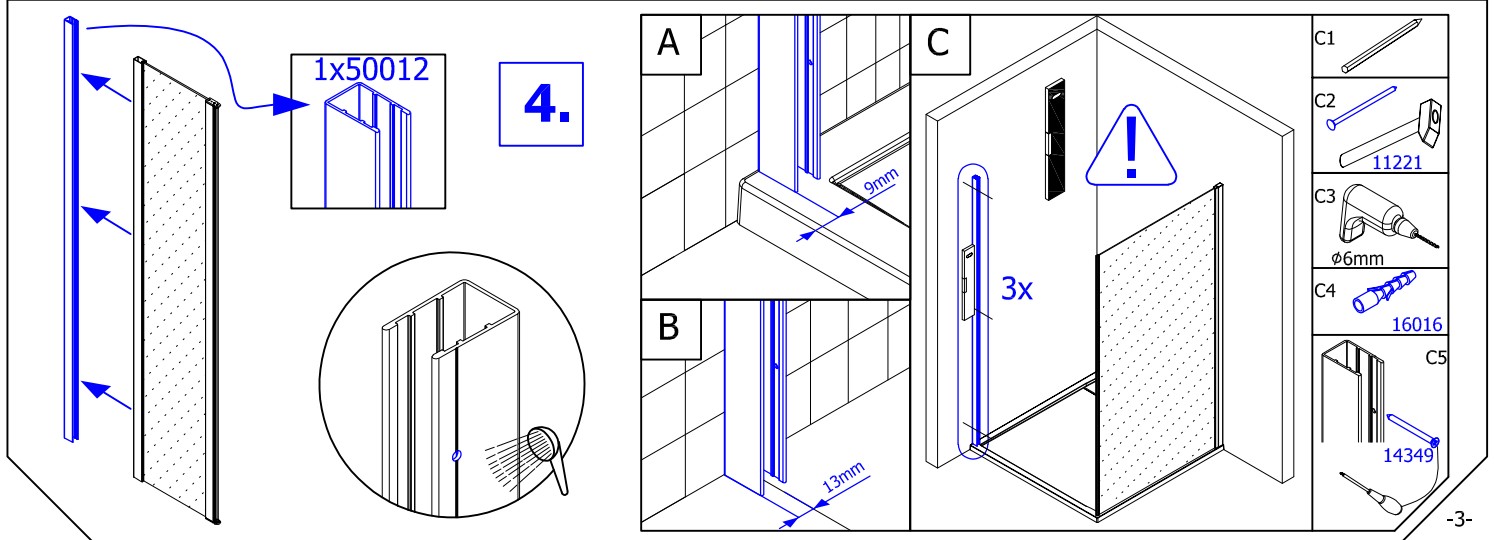
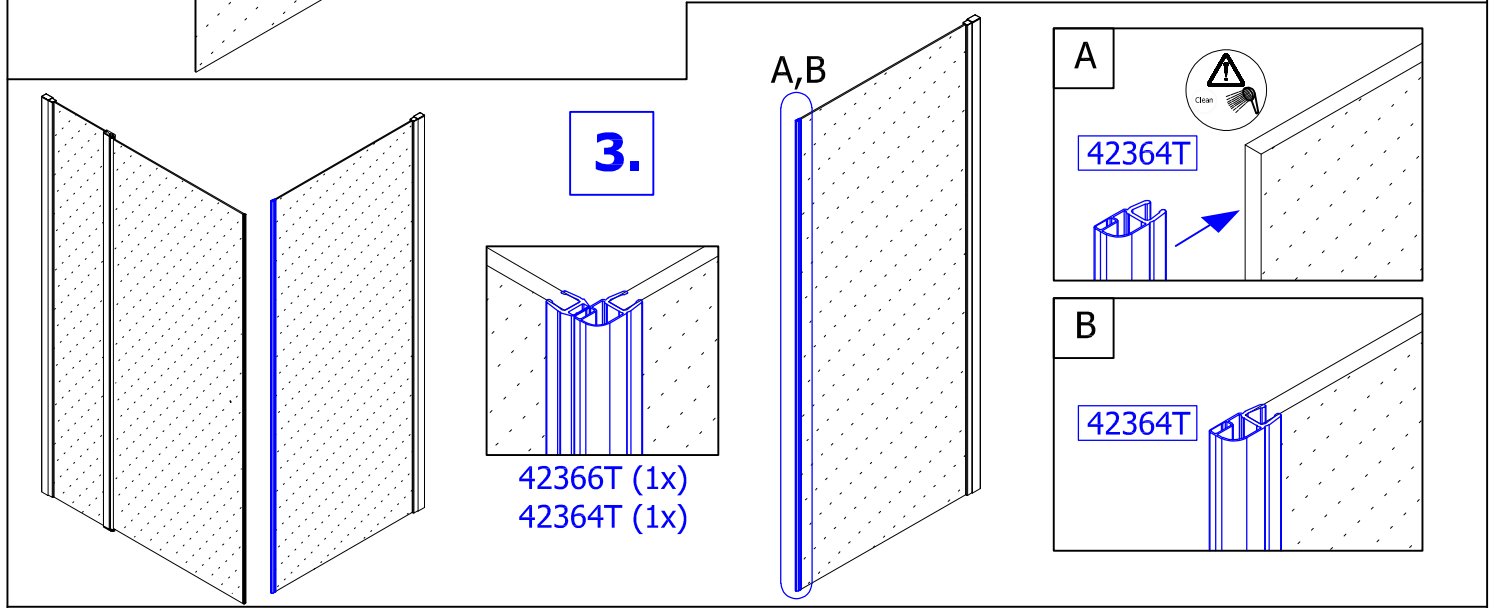
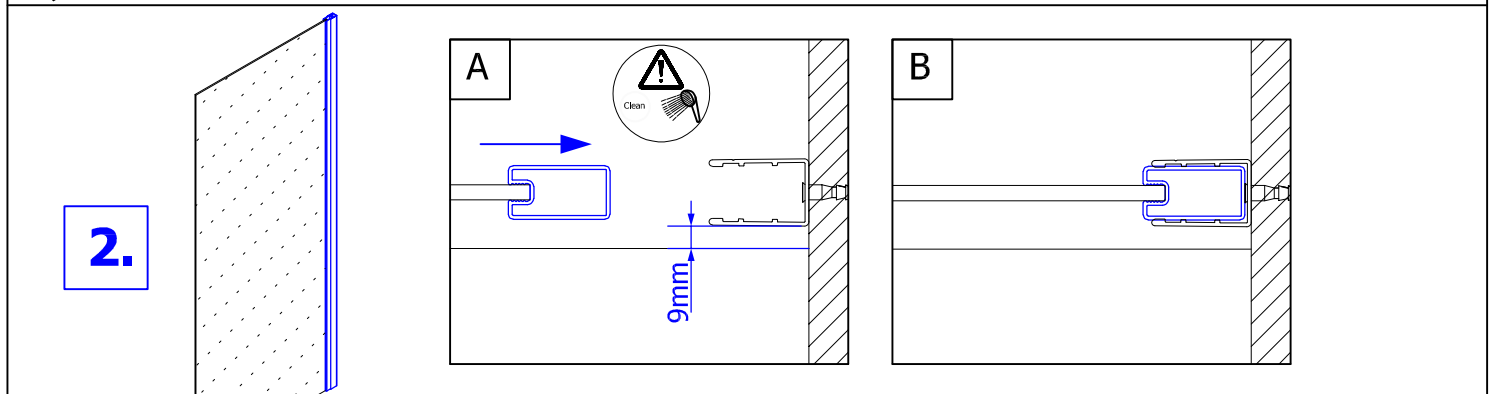
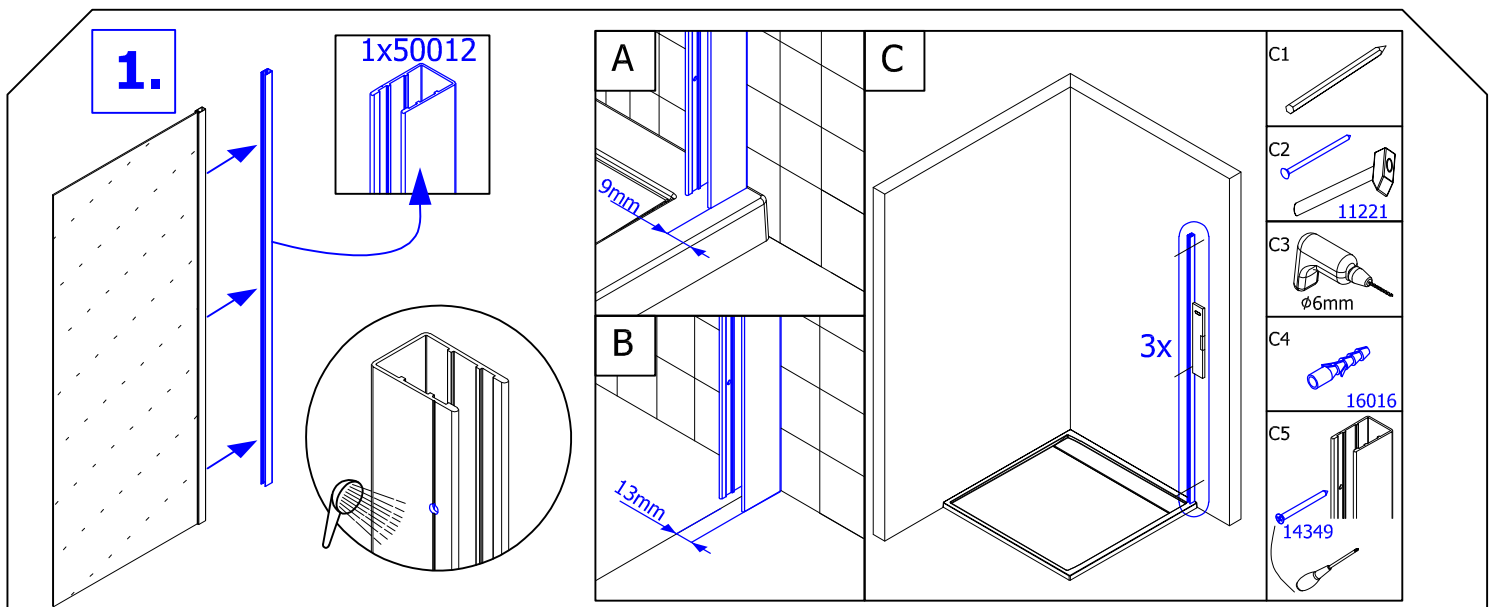

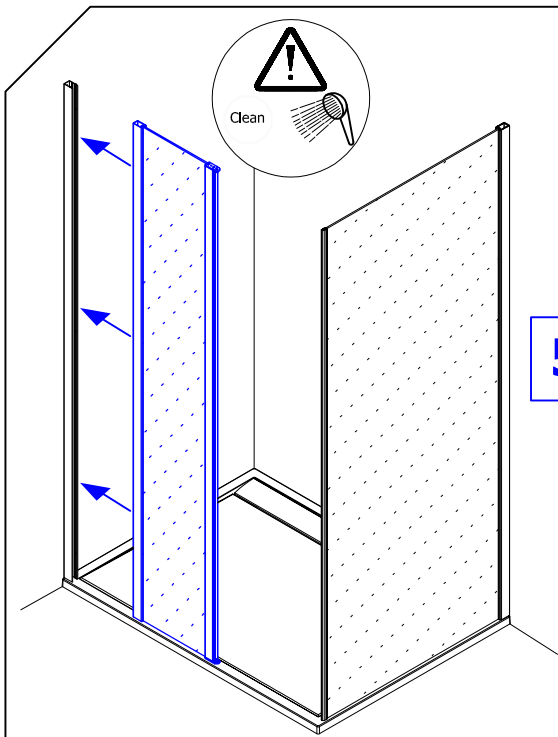

5.

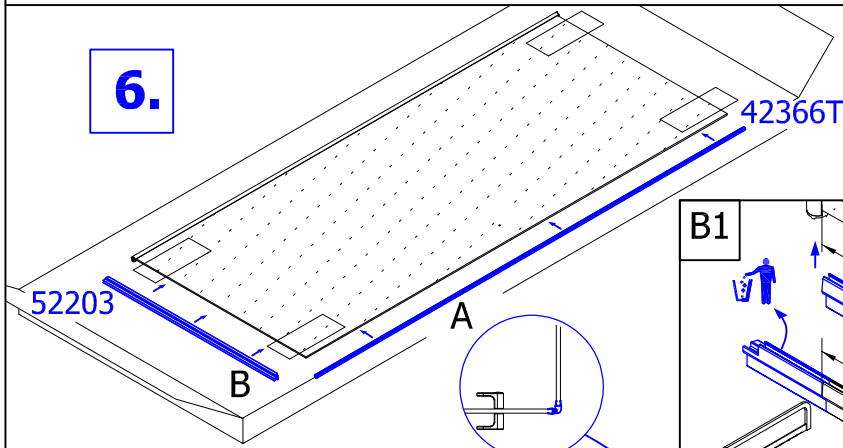
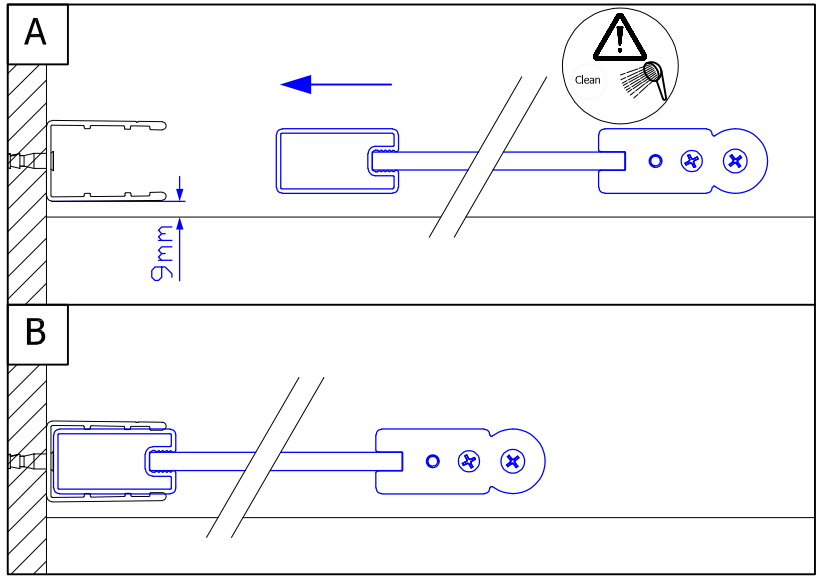

6.

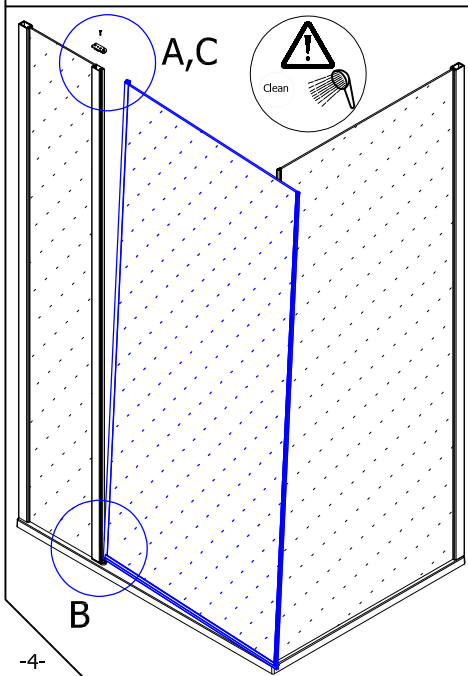
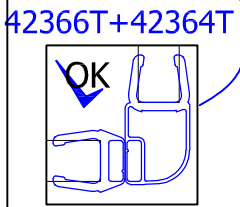
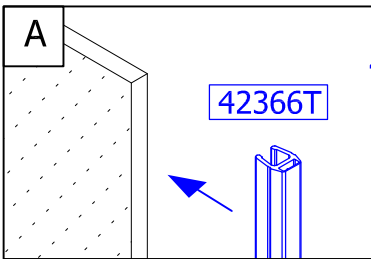
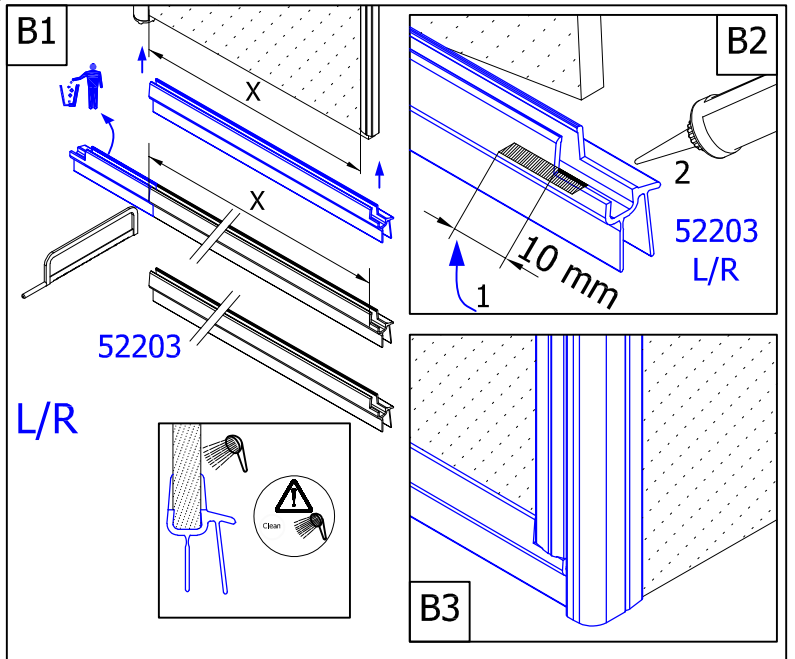

7.

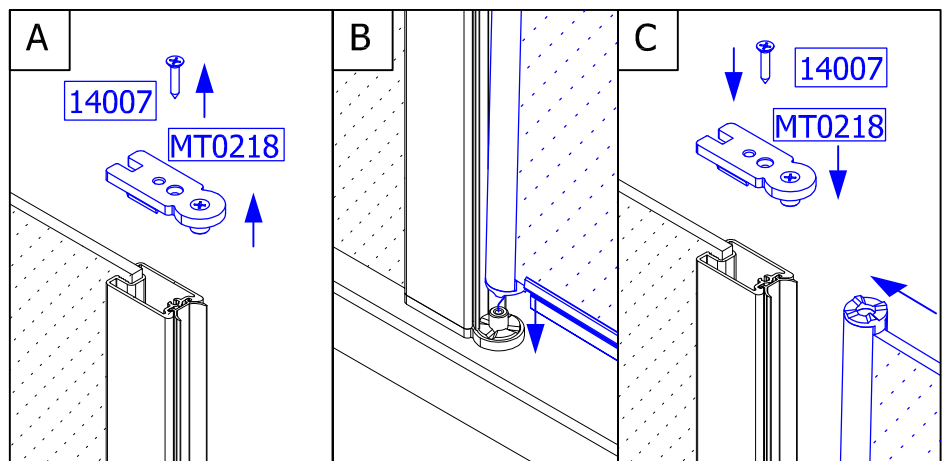

8.

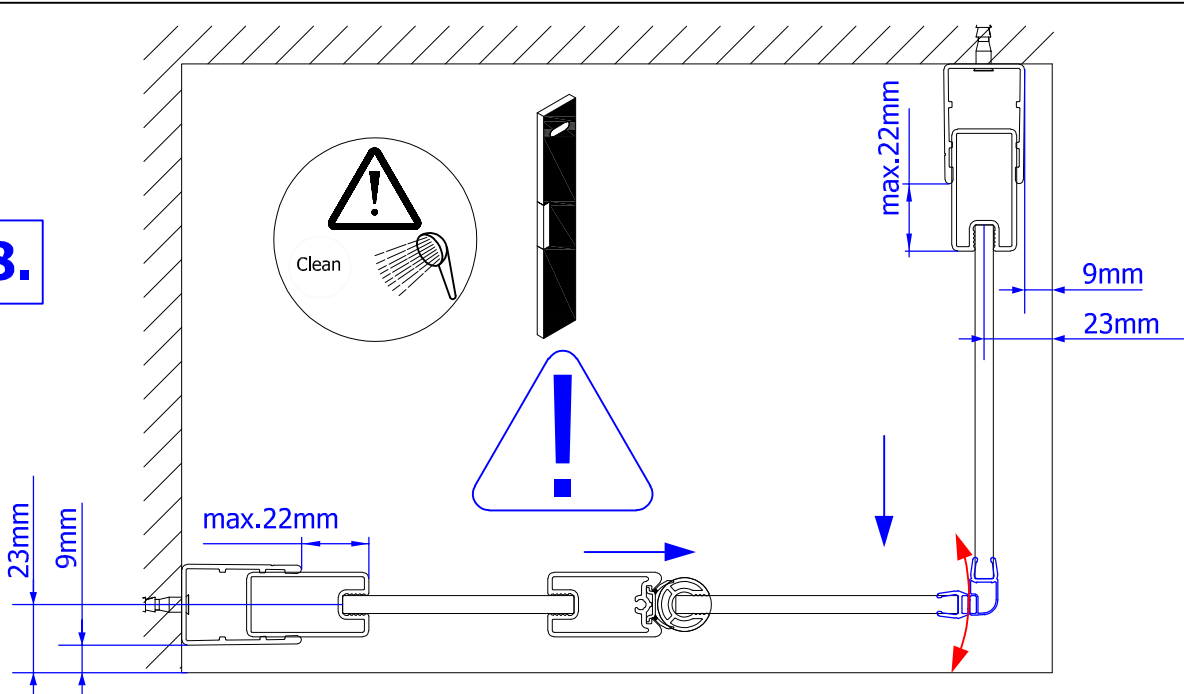

9.

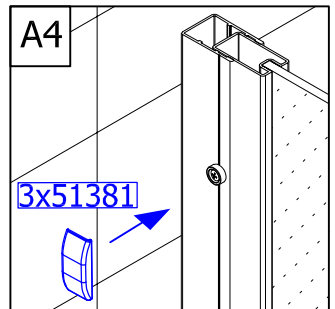
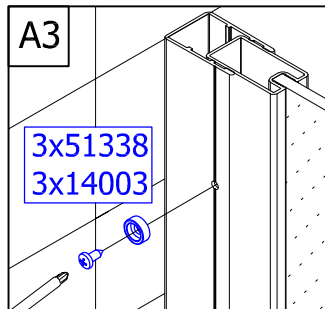
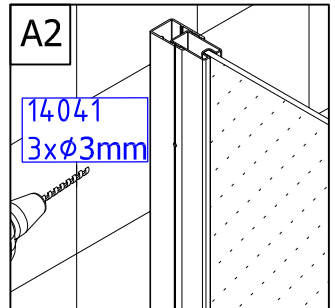
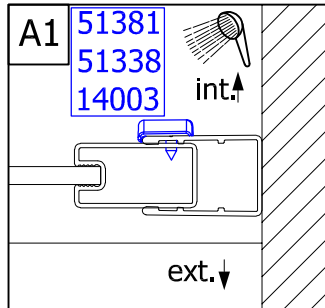
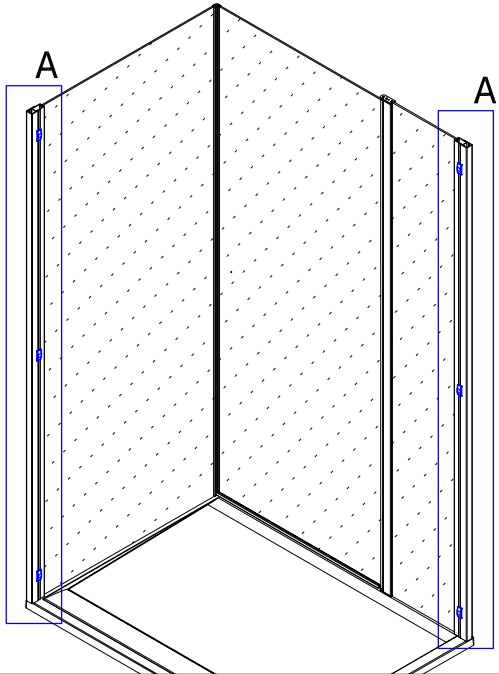

10.

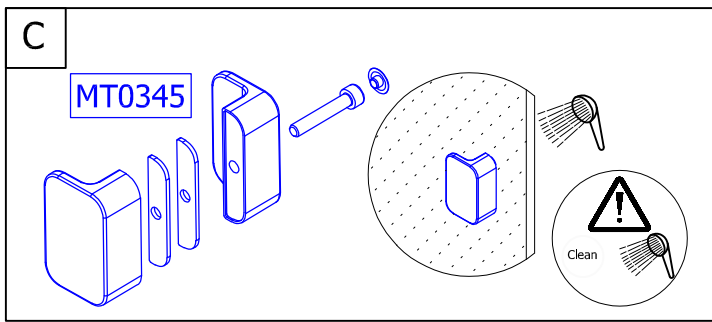
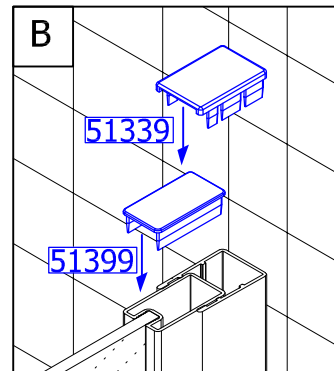
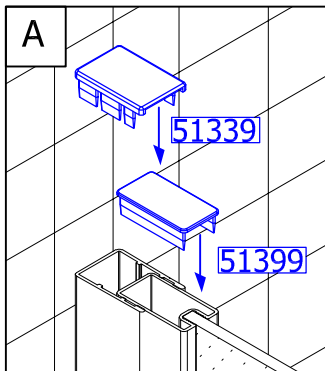
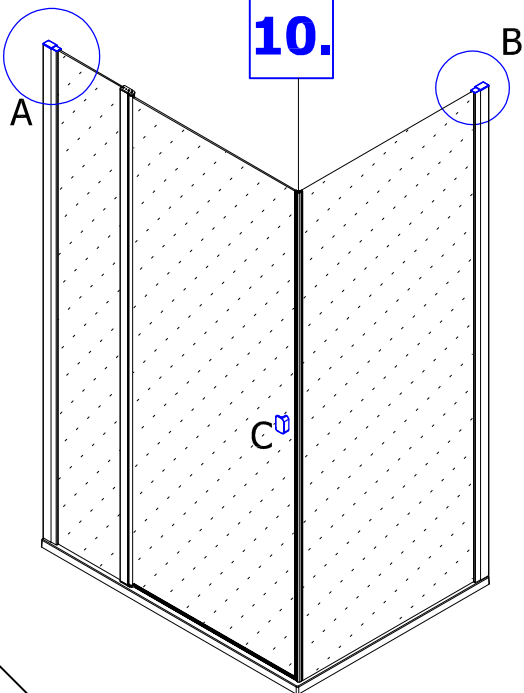

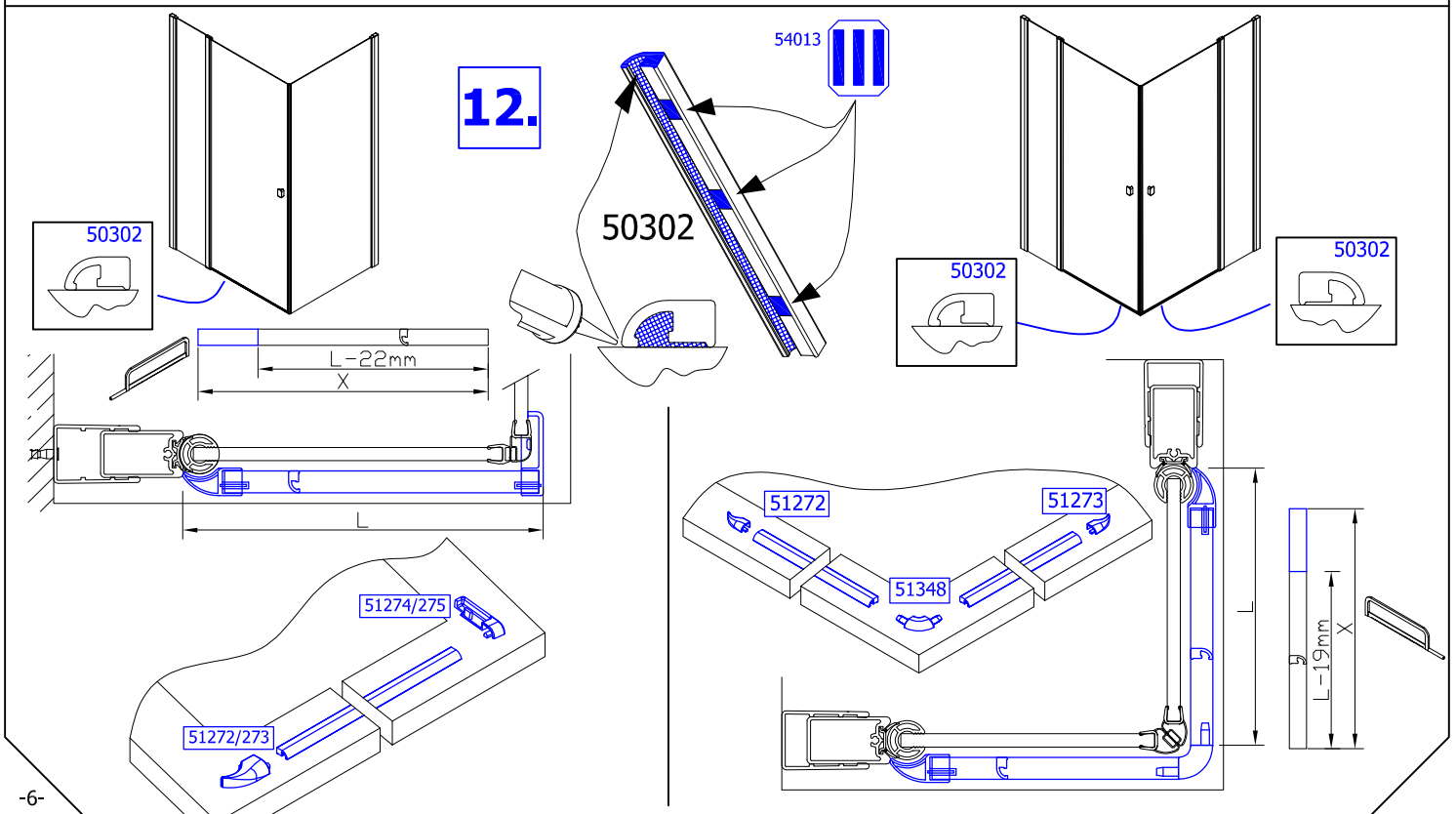
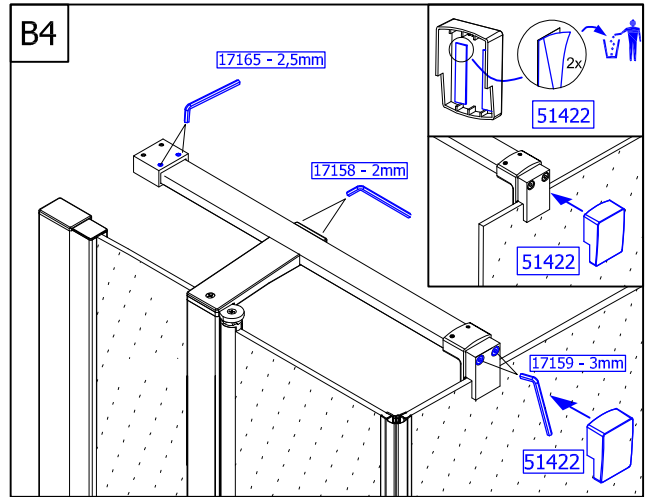
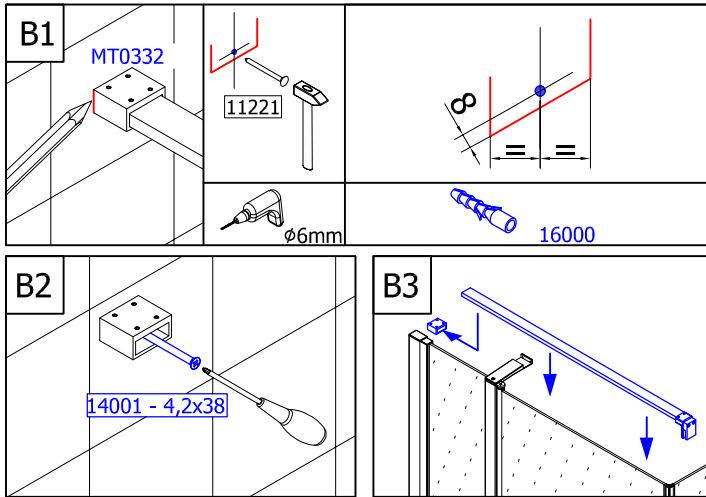
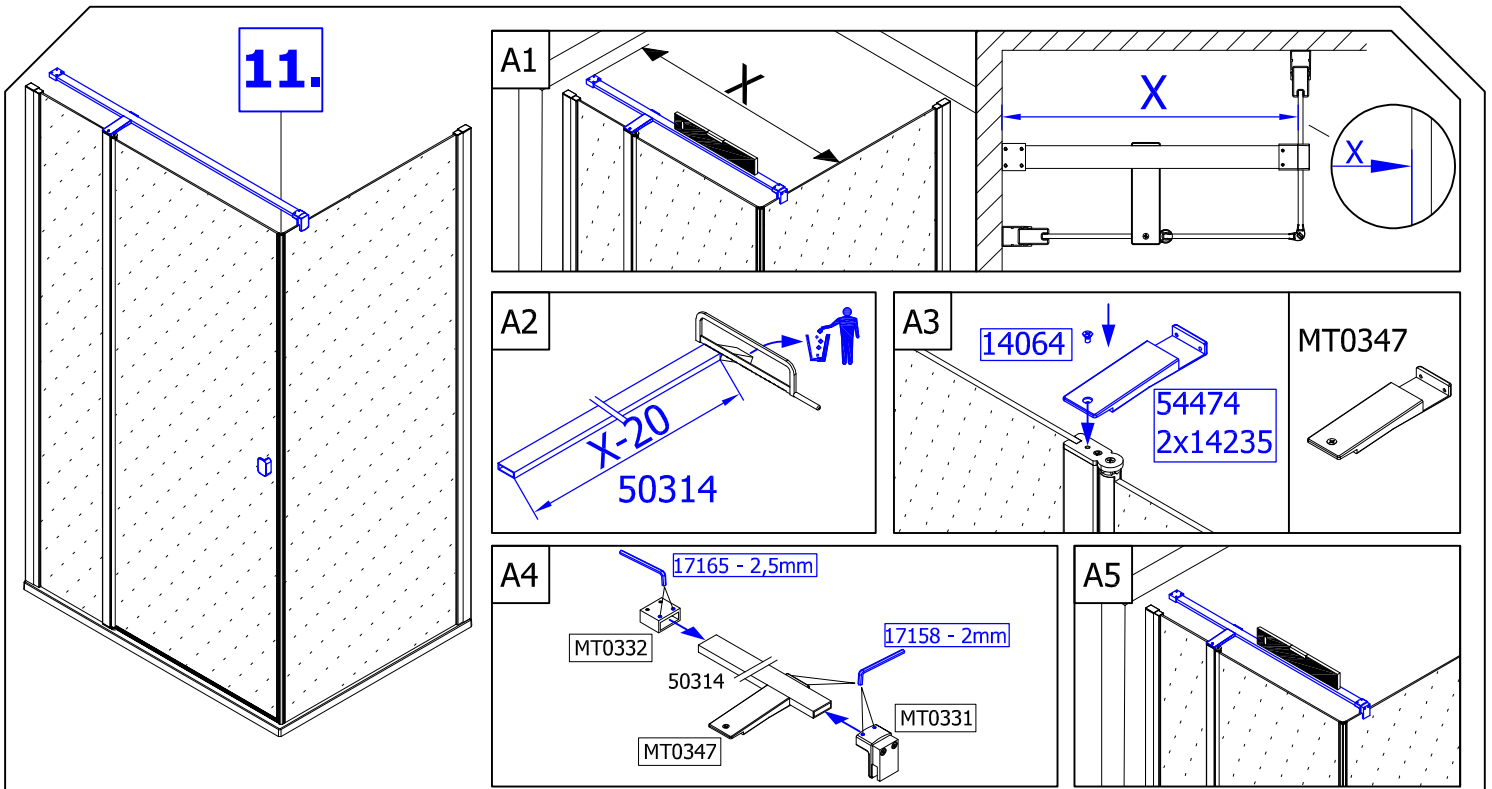

13.

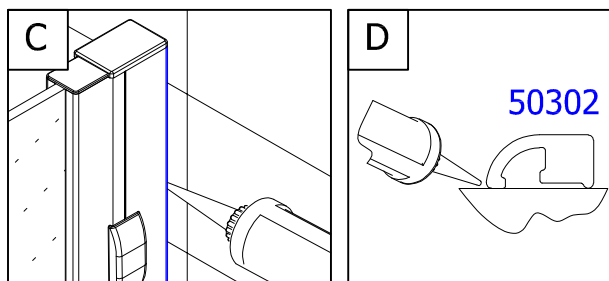
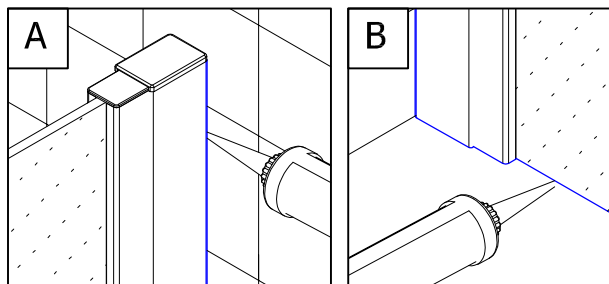
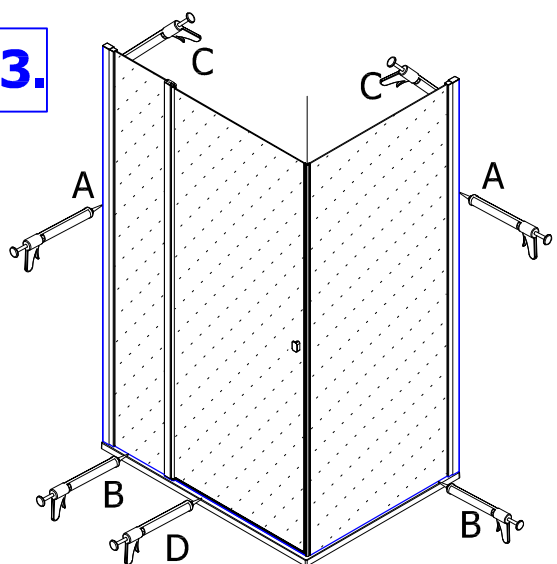

Achtung! Nur Sanitär-Silikon - bakterizid und fungizid eingestellt verwenden.

Caution! Use only bactericidal and fungicide sanitary silicone.

Attention! N'utiliser que du silicone sanitaire bactéricide et fongicide.

Pozor! Používejte pouze baktericidní a fungicidní sanitární silikon.

Uwaga! Stosować tylko silikon sanitarny - bakterio i grzybobójczy.

Pozor! Užívajte pouze baktericidný a fungicidný sanitárny silikón.

Opgepast! Breng enkel antibacteriële fungicide sanitaire siliconen aan

Varning! Använd endast antibakteriell sanitetssilikon

Atenție! Numai siliconul sanitar - bactericid și fungicid pot fi ajustate.

Viktig! Bruk KUN antibakteriell sanitør silikon

УВАГА! Застосовуйте тільки антибактеріальний санітарний силікон

Viktig! Bruk KUN antibakteriell sanitør silikon

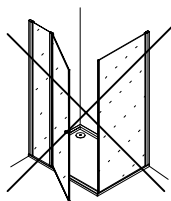
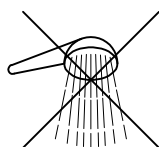

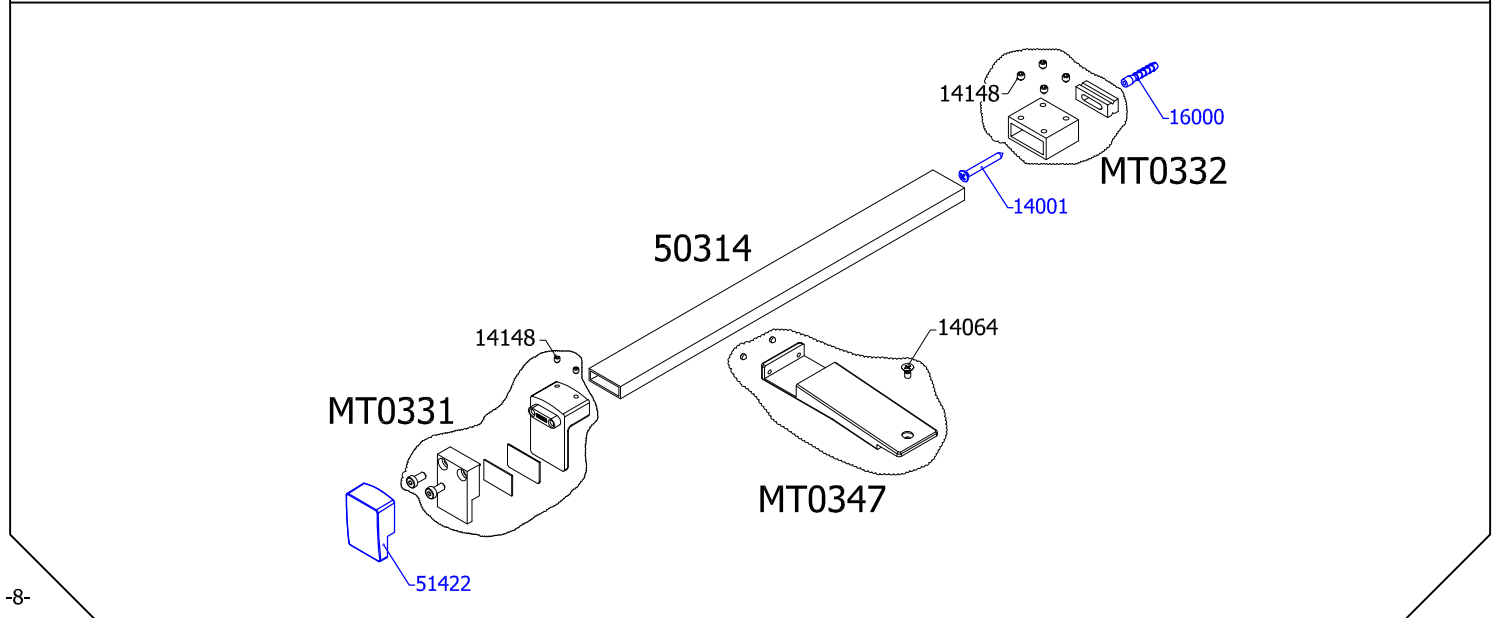
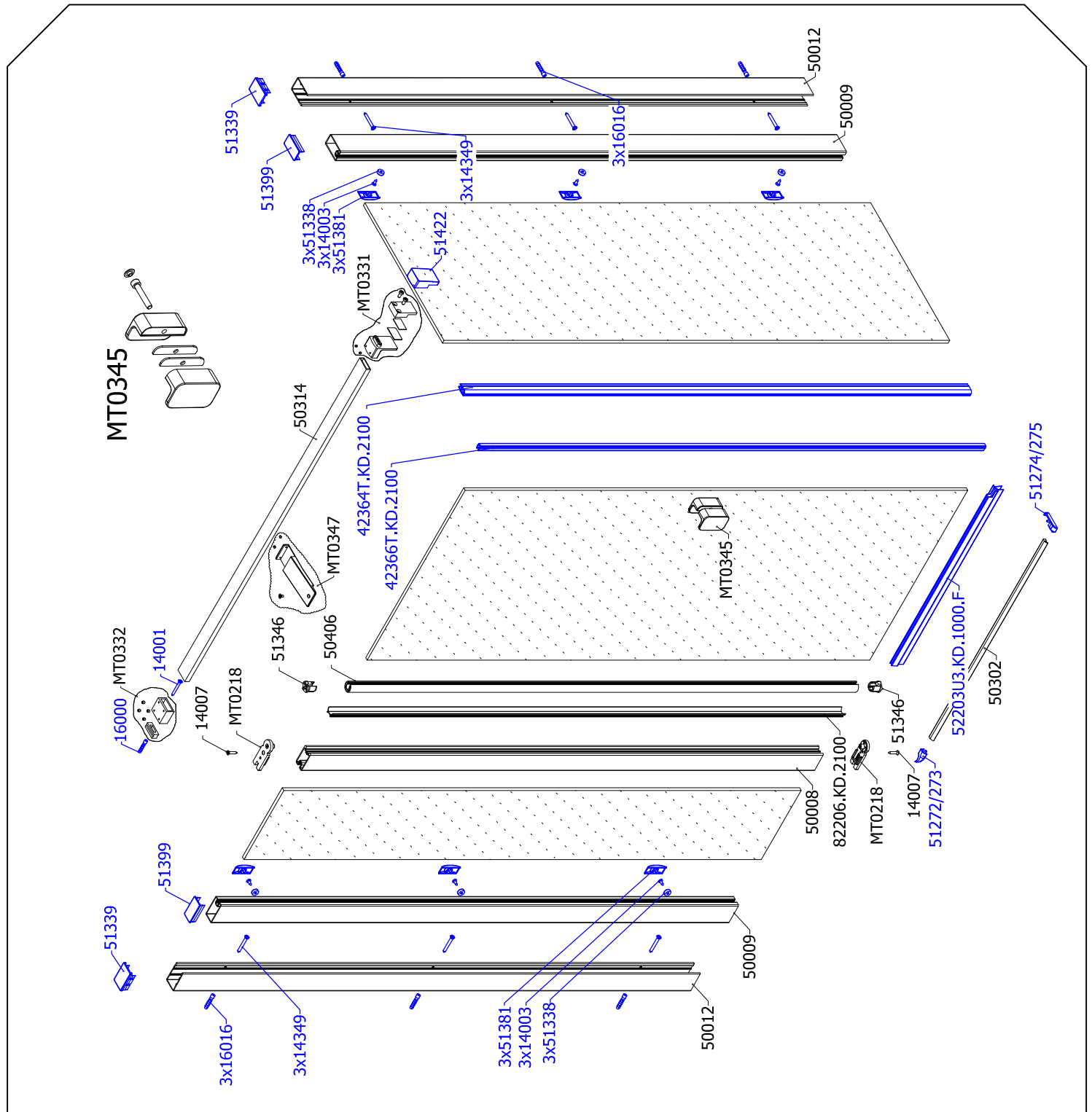

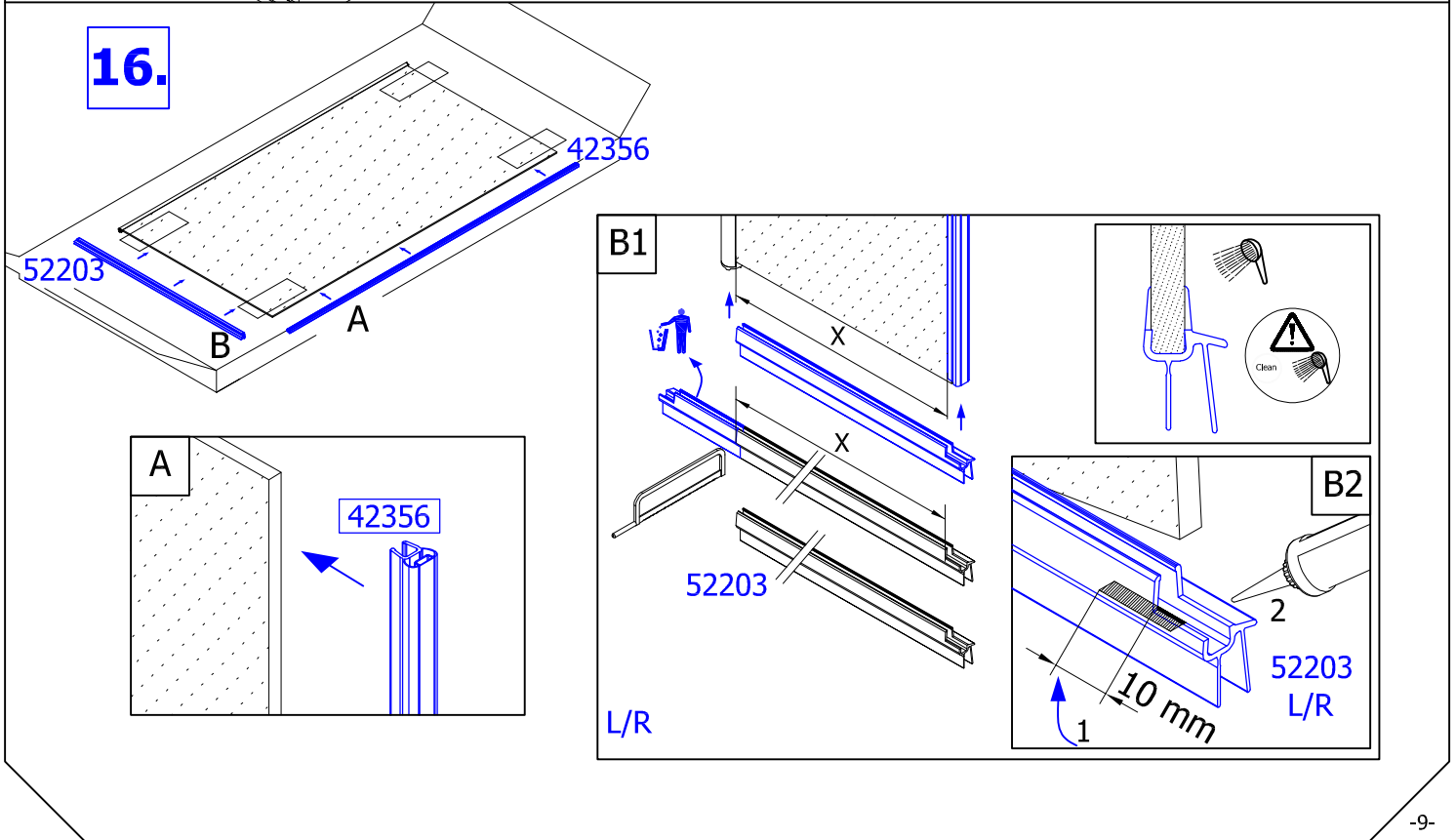
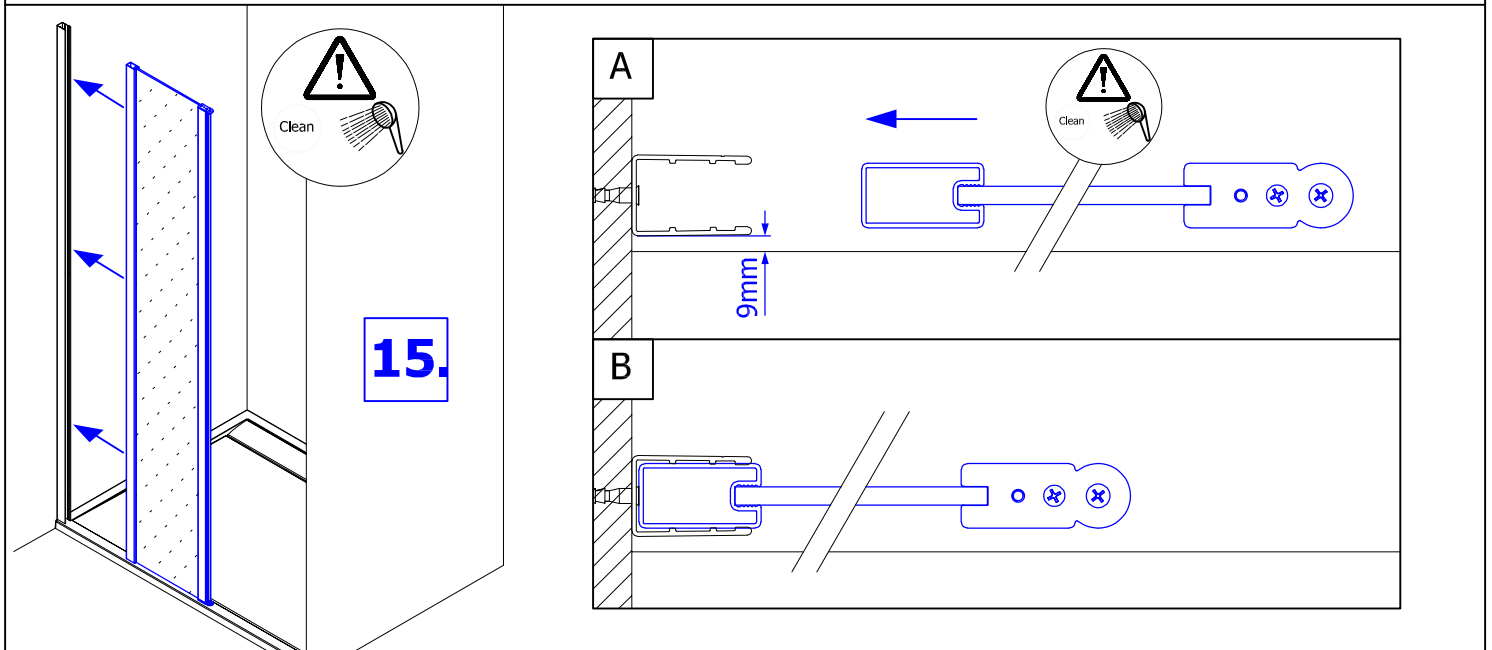
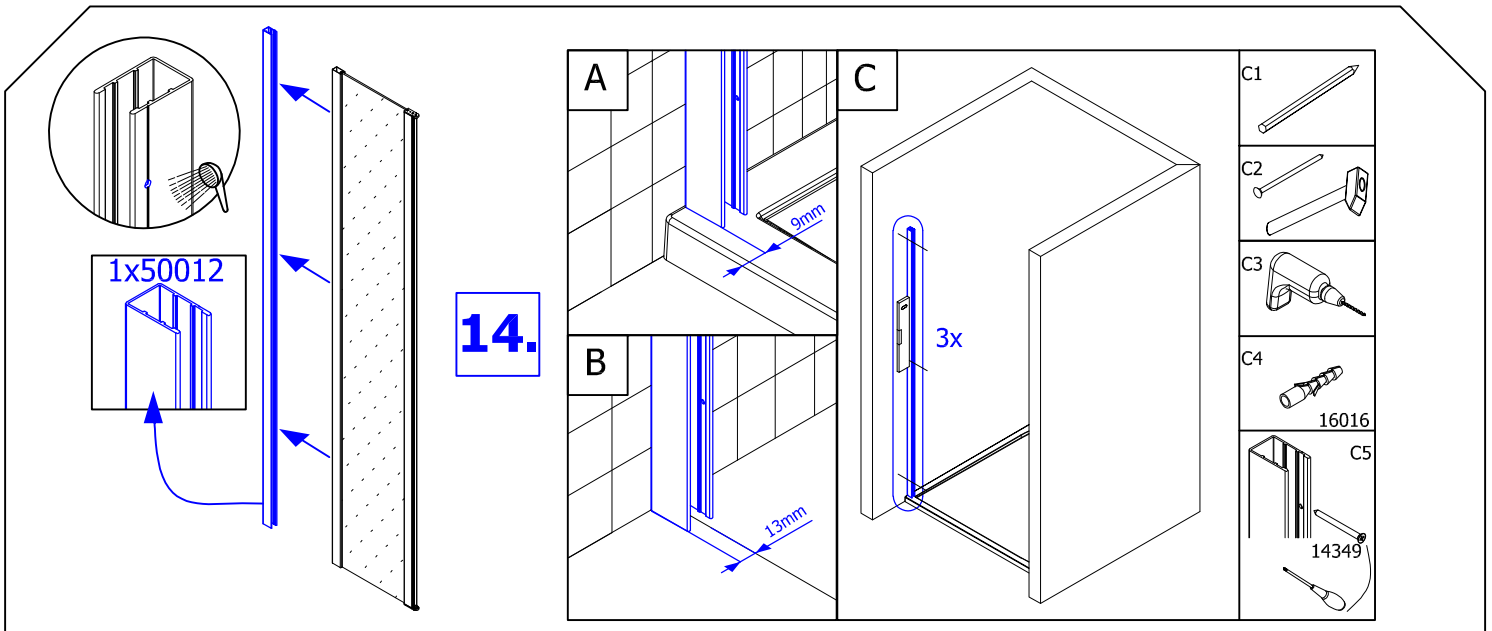

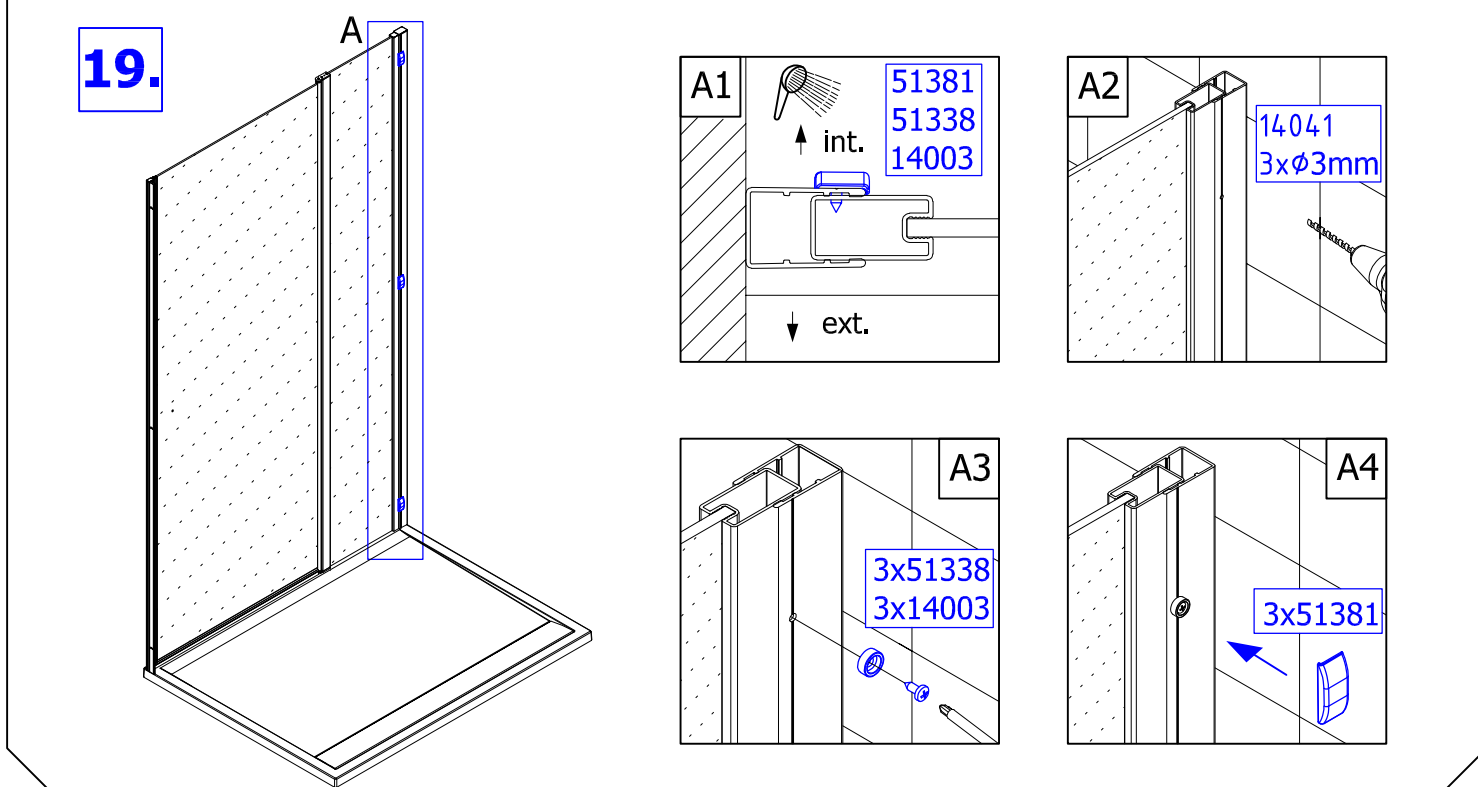
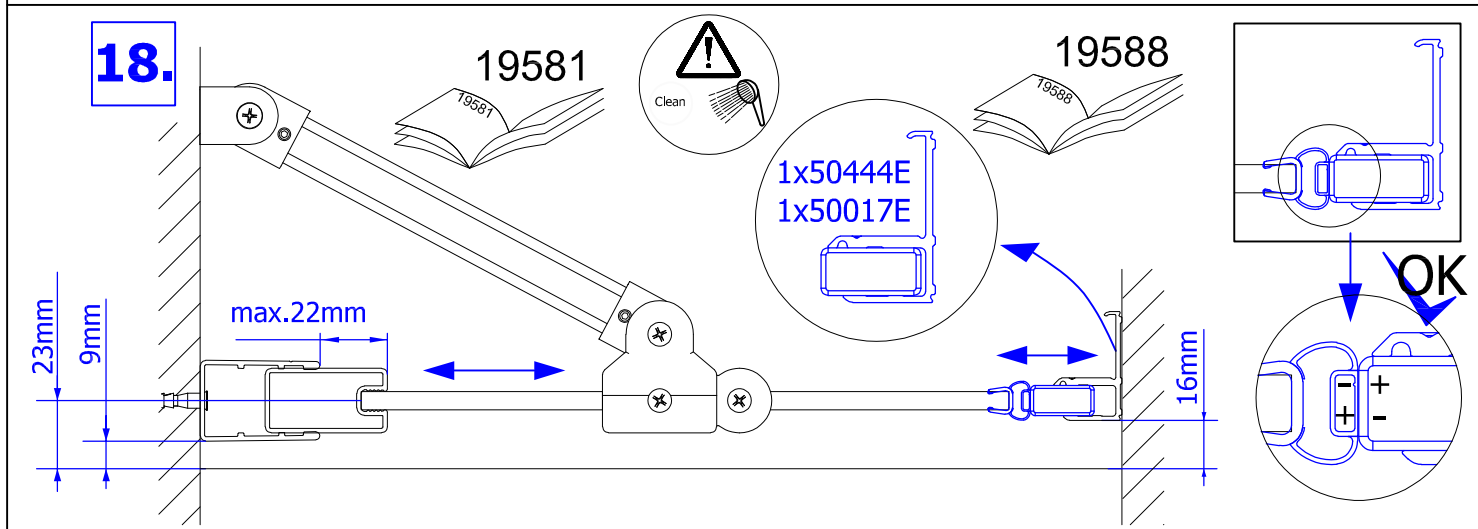
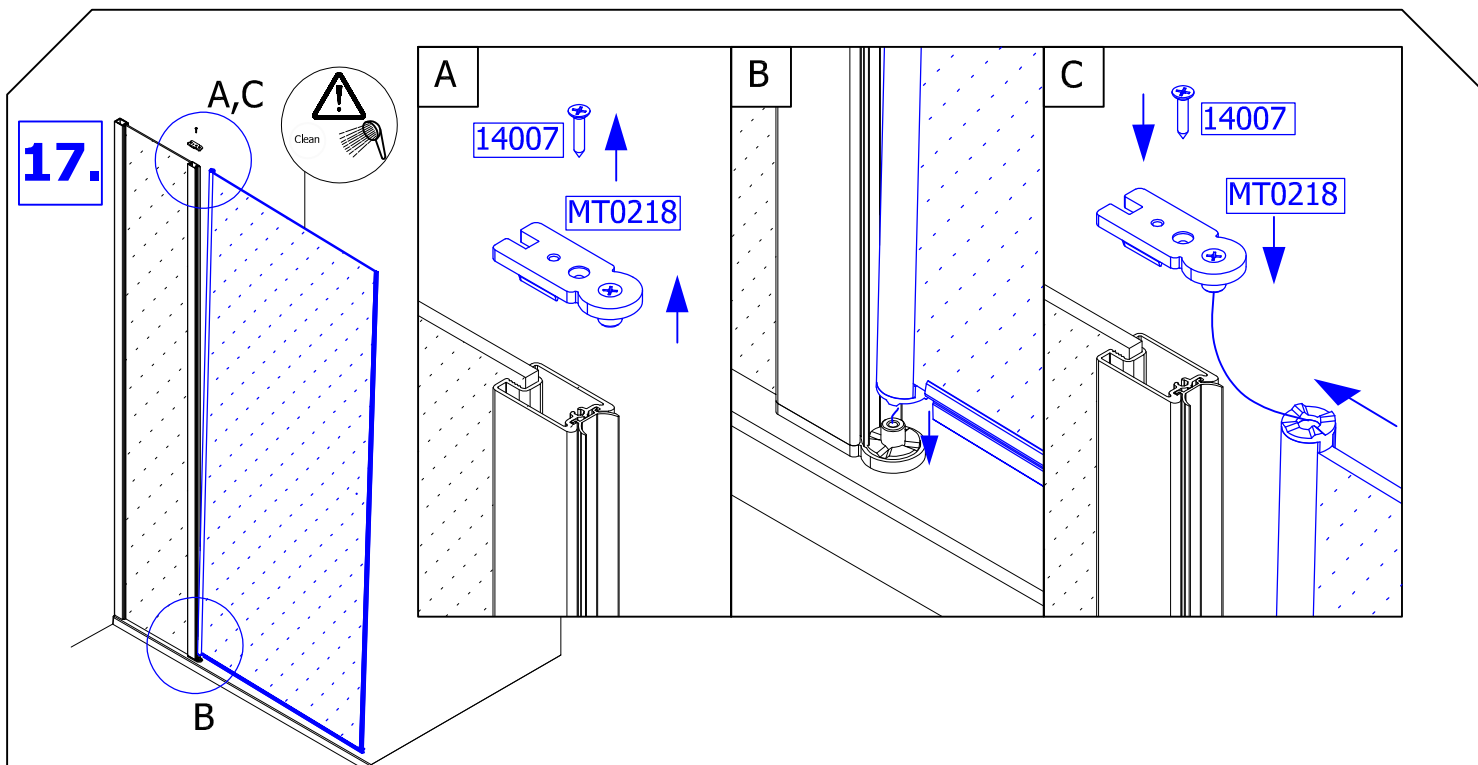

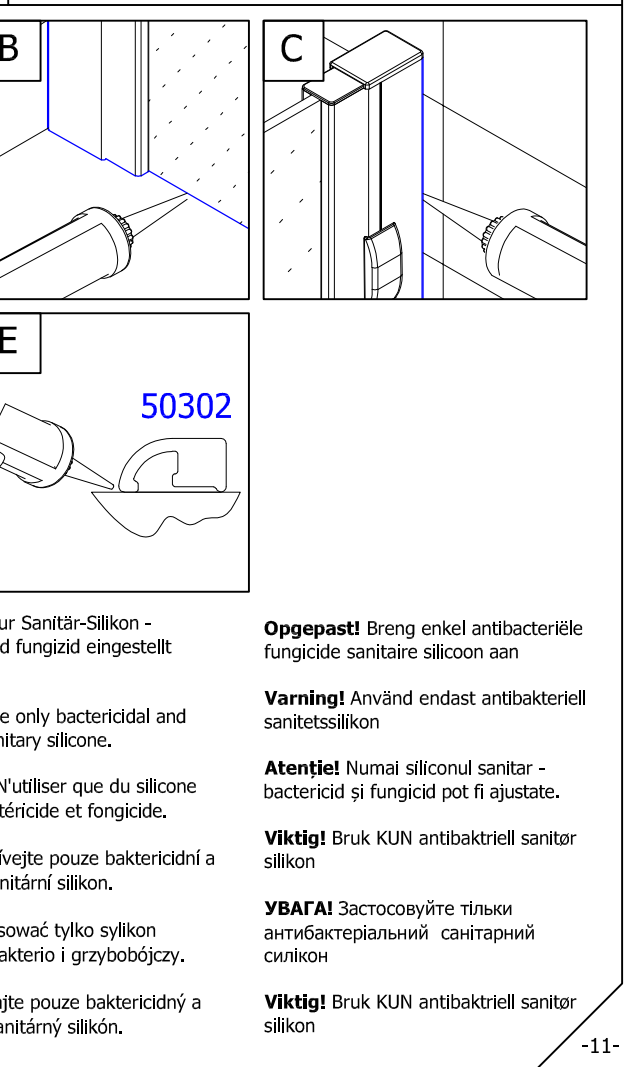
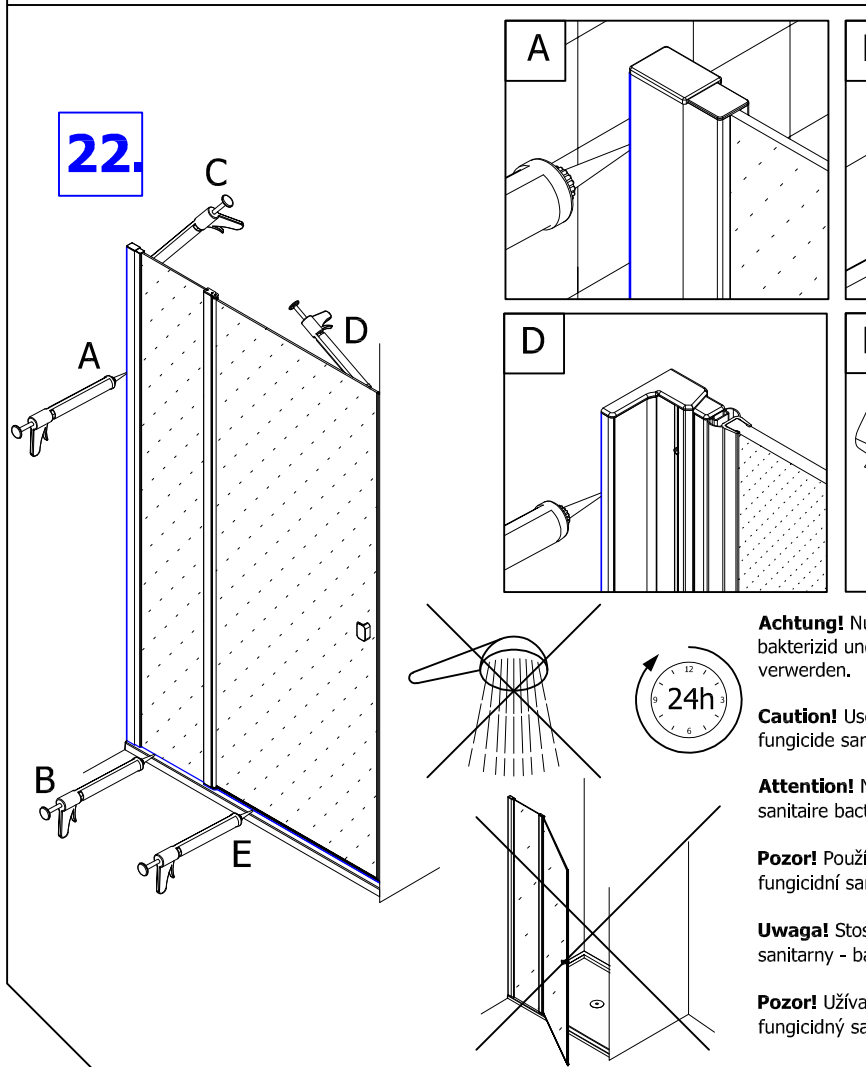
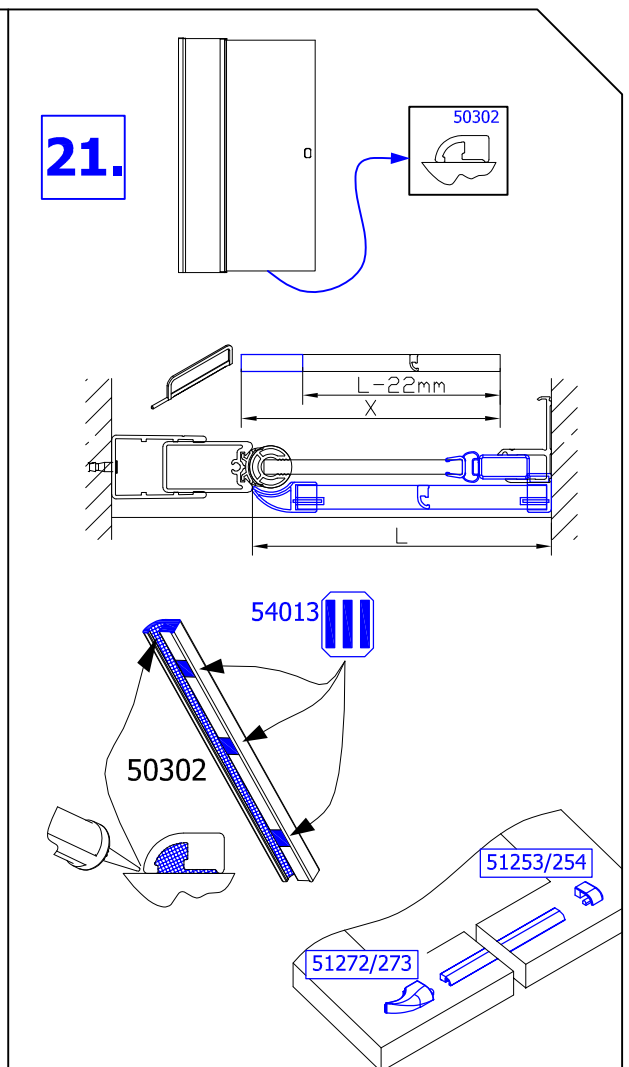
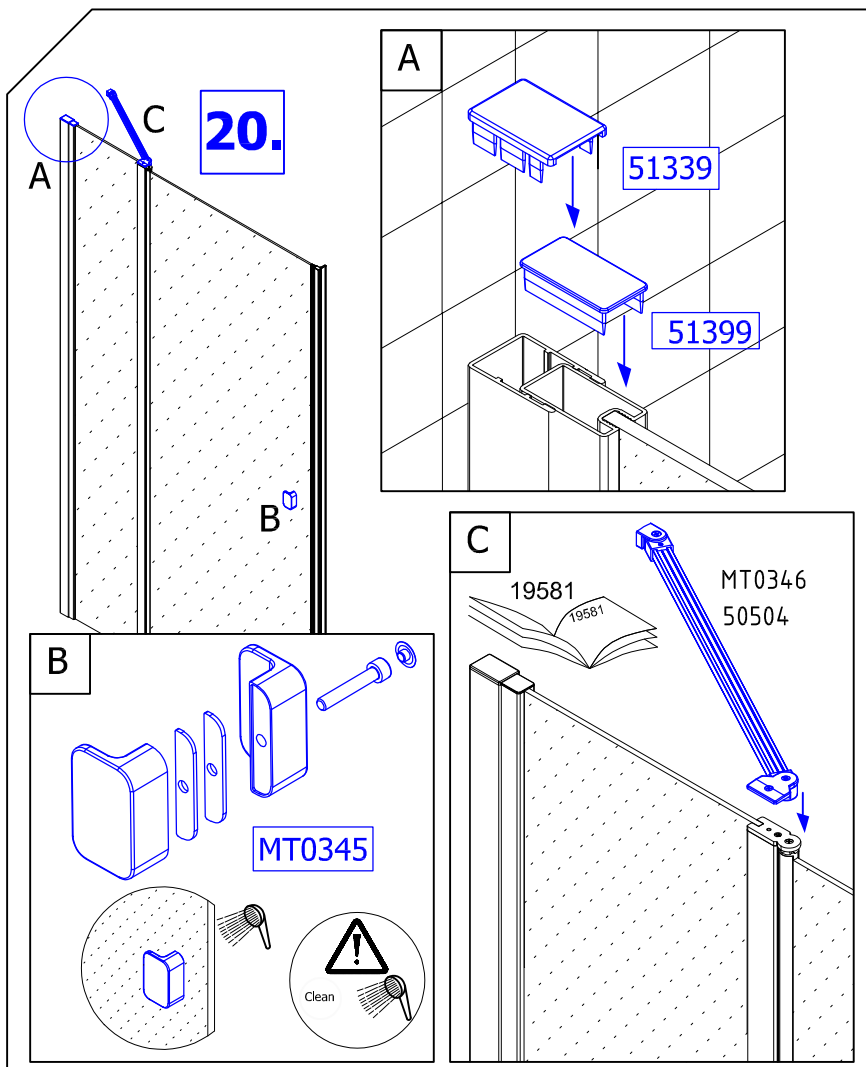

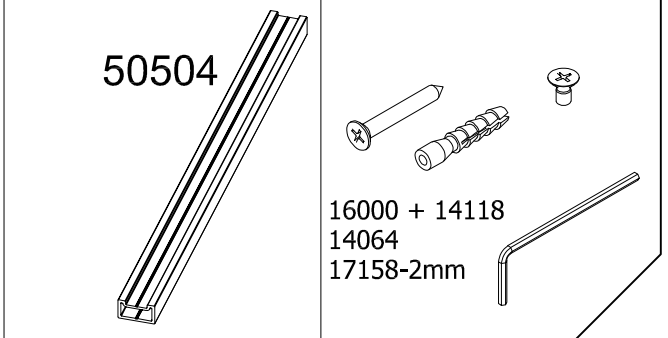
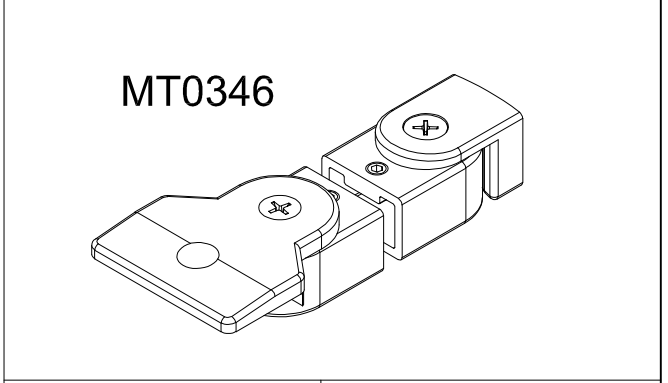
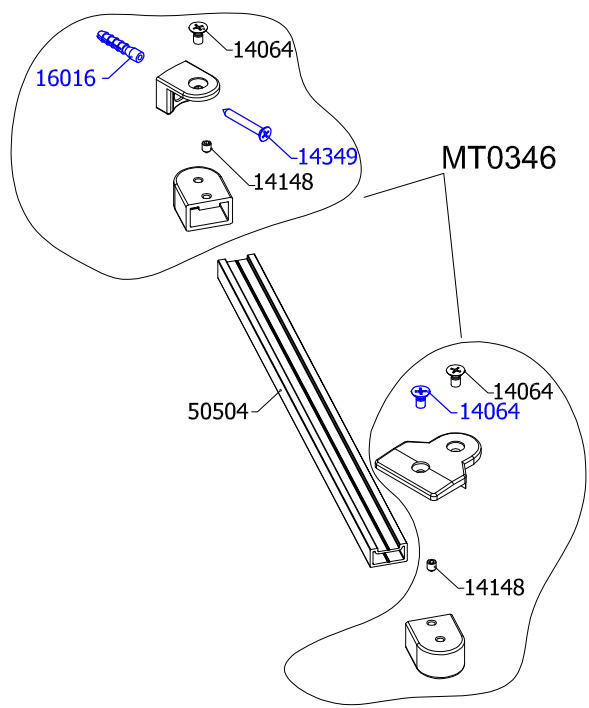
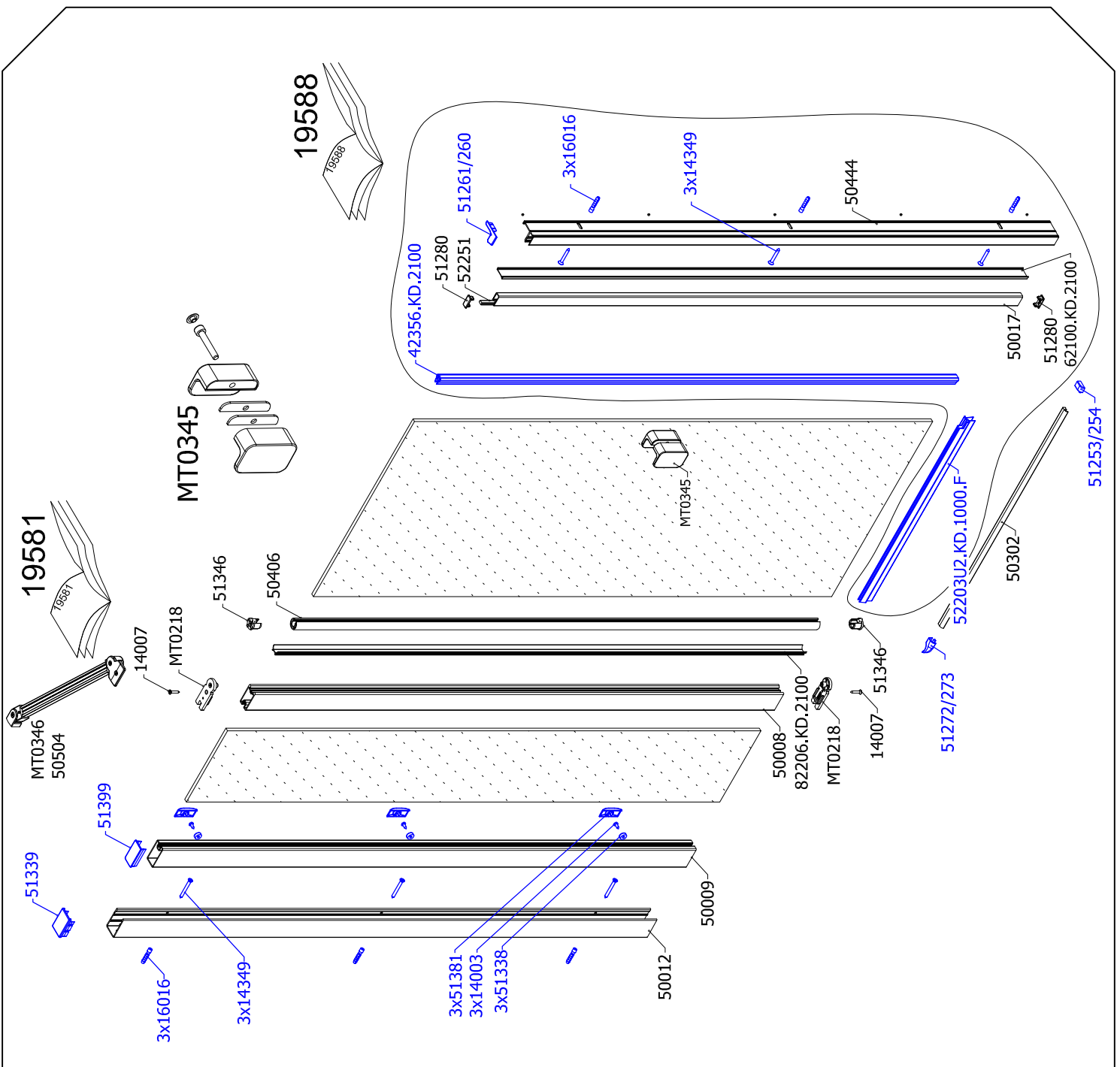

QUALITY CONTROL:

- DE** Dieses Produkt wurde unter sorgfältiger Beachtung der Qualitäts-Richtlinien gefertigt und vor dem Verpacken einer eingehenden Prüfung unterzogen. Sollten Sie dennoch einen Produktmangel oder eine Beschädigung feststellen, so setzen Sie sich bitte direkt mit der Firma in Verbindung, bei der Sie dieses Produkt gekauft haben.
- GB** This product was made with careful attention to quality guidelines and was subjected to a thorough examination before packaging. However, if you find a product defect or damage so please get in touch directly with the company in which you have bought this product.
- FR** Ce produit est fabriqué avec une attention particulière selon des normes de qualité et est soumis à un contrôle approfondi avant l'emballage. Toutefois, si le produit présente un défaut ou un dommage, veuillez prendre contact avec l'entreprise qui vous a vendu ce produit.
- CZ** Tento produkt byl vyroben s odbornou péčí podle příslušných kvalitativních směrnic a před zabalením byl důkladně zkontrolován. Pokud u něho přesto zjistíte závadu nebo poškození, kontaktujte prosím firmu, u které jste výrobek zakoupili.
- PL** Produkt ten został wyprodukowany z uwzględnieniem rygorystycznych norm jakościowych, a następnie podany drobiazgowej kontroli przed zapakowaniem. Jeżeli po rozpakowaniu (przed rozpoczęciem montażu!) stwierdzicie Państwo wady lub uszkodzenia to prosimy o natychmiastowe zgłoszenie tego faktu sprzedawcy.
- SK** Tento produkt bol vyrobený s odbornou starostlivosťou podľa príslušných kvalitatívnych smerníc a pred zabalením bol dôkladne skontrolovaný. Ak u neho aj napriek tomu zistíte závadu alebo poškodenie, kontaktujte prosím firmu, u ktorej ste výrobok zakúpili.
- NL** Dit product is gemaakt met zorgvuldige aandacht voor kwaliteitsrichtlijnen en werd onderworpen aan een grondig onderzoek voordat het verpakt werd. Mocht u echter schade of een defect vinden, neem dan rechtstreeks contact op met het bedrijf waar u dit hebt gekocht
- SW** Denna produkt har tillverkats enligt våra höga kvalitetskrav och har genomgått en grundlig undersökning innan den förpackades. Om du upptäcker någon defekt eller skada på produkten så vänligen kontakta företaget som sålt produkten till dig.
- RO** Acest produs a fost fabricat cu o atenție deosebită regulilor de calitate și a fost supus unei inspecții amănunțite înainte de ambalare. Cu toate acestea, dacă descoperiți un defect sau o deteriorare a produsului, vă rugăm să contactați direct compania de la care ați achiziționat produsul..
- DK** Produktet er produceret i henhold til våre høye og strenge kvalitets krav og testet nøye for innpakking. Ta kontakt med sals stedet om du oppdager noen uregelmessigheter
- UA** Цей продукт був виготовлений з особливою увагою до інструкцій з якості та був ретельно перевірений перед пакуванням. Однак, якщо ви виявите дефект або пошкодження продукту, зв'яжіться безпосередньо з компанією, в якій ви придбали цей продукт.
- NO** Produktet er produsert i henhold til våre høye og strenge kvalitets krav og testet nøye for innpakking. Ta kontakt med sals stedet om du oppdager noen uregelmessigheter

.....
.....
.....
.....
.....