

Notre service technique est
à votre écoute aux numéros
qui sont au dos de cette
notice d'installation

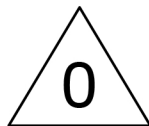

GIR1415NG-B

● Position de la cabine ● Position of the shower cubicle
 ● Posición de la cabina de ducha ● Posizione della cabina doccia
 ● Positie van de douchecabine ● Position der Duschkabine

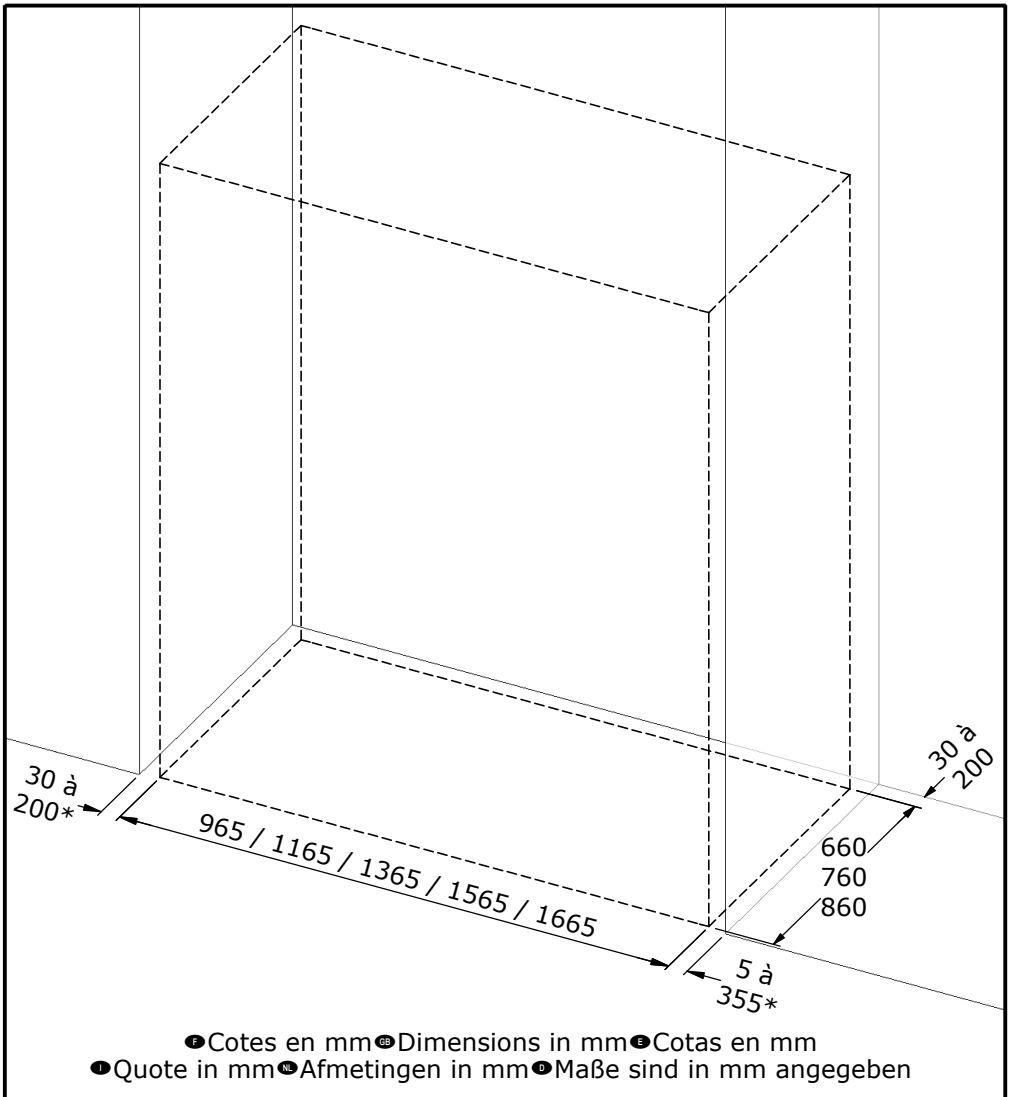

* ● Côté gauche et droit cumulés ne peuvent excéder 385 mm.

● Left and right sides summed must not exceed 385 mm.

● Las cuotas agregadas izquierda y derecha no pueden superar 385 mm.

● Sinistra e destra combinati non possono superare 385 mm.

● De linker- en rechterzijde mogen samen niet groter zijn dan 385 mm.

● Links und rechts dürfen es zusammen nicht mehr als 385 mm sein.

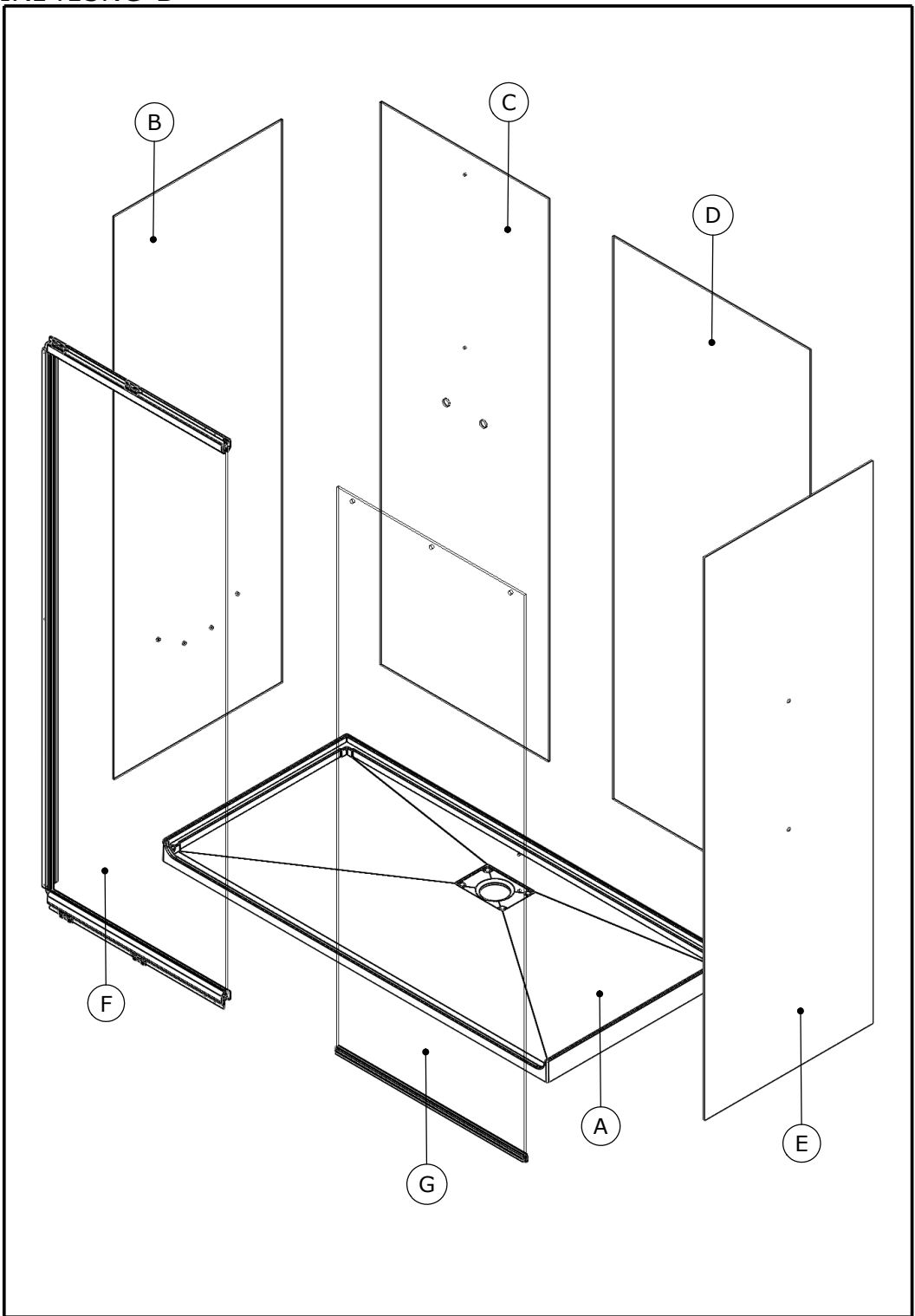

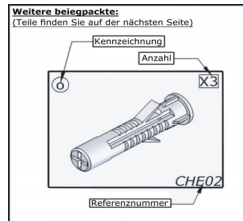
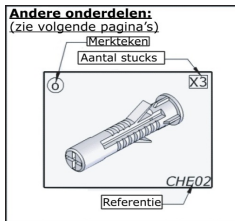
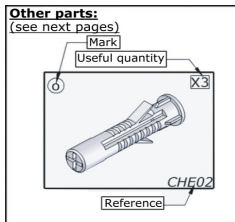
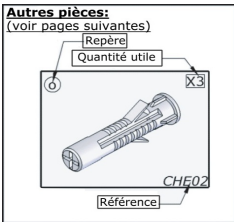

- CODE COLIS (Voir repères en page 4)
- PACKAGE CODES (See marks on page 4)
- REF. BULTOS (Ver pg. 4 para listado de bultos)
- CODE SET (zie blz. 4)
- Codering verpakking (zie omschrijving op pagina 4)
- PAKETCODES (siehe Kennzeichnungen auf Seite 4)

REP	VERSION	100 x 70	100 x 80	100 x 90	120 x 70	120 x 80	120 x 90	140 x 70	140 x 80	140 x 90	160 x 70	160 x 80	160 x 90	170 x 70	170 x 80	170 x 90		
A		REC561	REC562	REC563	REC564	REC565	REC566	REC567	REC568	REC569	REC570	REC571	REC572	REC573	REC574	REC575		
B		C11444E	C11445E	C11446E	C11444E	C11445E	C11446E	C11444E	C11445E	C11446E	C11444E	C11445E	C11446E	C11444E	C11445E	C11446E		
C		C11430E					C11429E											
D							C11409E			C11411E			C11414E			C11413E		
E		C11354E	C11355E	C11356E	C11354E	C11355E	C11356E	C11354E	C11355E	C11356E	C11354E	C11355E	C11356E	C11354E	C11355E	C11356E		
F	SER	CLT	C11374E			C11375E			C11376E			C11377E			C11378E			
		PVT/ SOLO	C11381E			C11382E			C11498E			C11496E			C11420E			
	TN	CLT	C11369E			C11370E			C11371E			C11372E			C11373E			
		PVT/ SOLO	C11379E			C11380E			C11497E			C11421E			C11419E			
G	SER	CLT	C11394E			C11395E			C11396E			C11397E			C11398E			
		PVT	C11401E			C11401E												
	TN	CLT	C11389E			C11390E			C119391E			C11392E			C11393E			
		PVT	C11399E			C11399E												

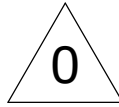

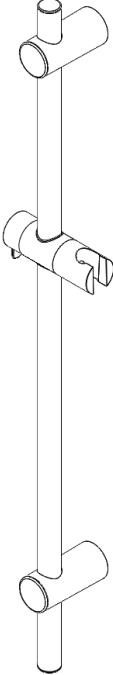
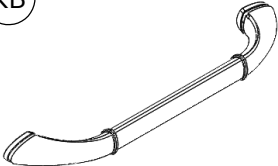
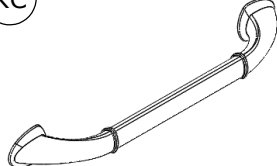
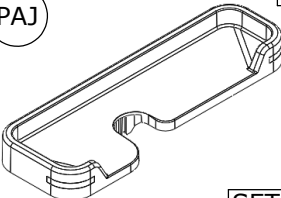

<p>SK</p> <ul style="list-style-type: none"> ● Montage gauche ● Left hand ● Montaje a la izquierda ● Montaggio a sinistra ● Montage links ● Montage links <p>SUP172 x1</p>	<p>SL</p> <ul style="list-style-type: none"> ● Montage droite ● Right hand ● Montaje a la derecha ● Montaggio a destra ● Montage rechts ● Montage rechts <p>SUP173 x1</p>	<p>PS</p> <p>PPL1116 x2</p>
<p>SC</p> <ul style="list-style-type: none"> ● Montage gauche ● Left hand ● Montaje a la izquierda ● Montaggio a sinistra ● Montage links ● Montage links <p>SUP164 x1</p>	<p>SD</p> <ul style="list-style-type: none"> ● Montage droite ● Right hand ● Montaje a la derecha ● Montaggio a destra ● Montage rechts ● Montage rechts <p>SUP165 x1</p>	<p>PT 120/140/160/170 x1 100 x0</p> <p>PPL1117</p>
<p>PG</p> <ul style="list-style-type: none"> ● Montage gauche ● Left hand ● Montaje a la izquierda ● Montaggio a sinistra ● Montage links ● Montage links <p>PPL1102 x1</p>	<p>PH</p> <ul style="list-style-type: none"> ● Montage droite ● Right hand ● Montaje a la derecha ● Montaggio a destra ● Montage rechts ● Montage rechts <p>PPL1103 x1</p>	<p>MA</p> <p>MIT98 x1</p>
<p>PAB</p> <ul style="list-style-type: none"> ● Montage gauche ● Left hand ● Montaje a la izquierda ● Montaggio a sinistra ● Montage links ● Montage links <p>PPL1134 x1</p>	<p>PAC</p> <ul style="list-style-type: none"> ● Montage droite ● Right hand ● Montaje a la derecha ● Montaggio a destra ● Montage rechts ● Montage rechts <p>PPL1135 x1</p>	<p>MB</p> <p>MIT99 x1</p>
<p>PAX</p> <p>PPL1318 x4</p>	<p>VG</p> <p>SET03 x2</p>	<p>MIT99</p> <p>MIT99</p>

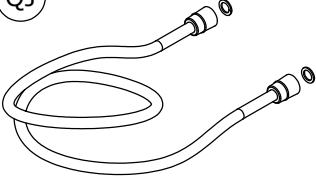
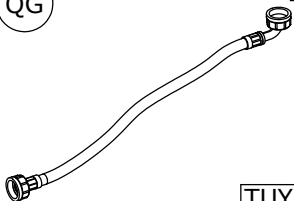
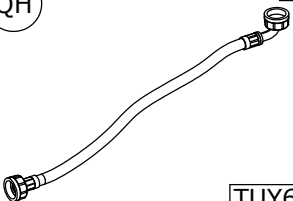
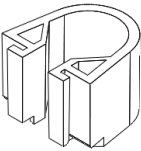
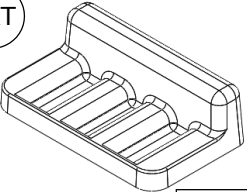
<p>(KK)  x1</p> <p style="text-align: right;">KIT178</p>	<p>(KB)  x1</p> <p>Lg=450mm S2542</p>	<p>(KC)  x1</p> <p>Lg=450mm S2544</p>
<p>(PAJ)  x1</p> <p style="text-align: right;">SET86</p>	<p>(KL)  x1</p> <p style="text-align: right;">KIT212</p>	<p>(QJ)  x1</p> <p style="text-align: right;">FLEX05</p>
<p>(QG)  x1</p> <p style="text-align: right;">TUY60</p>	<p>(QH)  x1</p> <p style="text-align: right;">TUY61</p>	<p>(PAQ)  x1</p> <p style="text-align: right;">PPL980</p>
<p>(PAT)  x1</p> <p style="text-align: right;">PPL1141</p>		

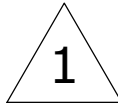

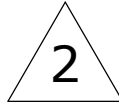

<p>PA 120/140/160/170 x11 100 x9</p> <p>PPL802</p>	<p>PB 120/140/160/170 x11 100 x9</p> <p>PPL804</p>	<p>QA</p> <p>BOND28</p>													
<p>TA x1</p> <p>TOL11</p>	<p>VN Ø4 x11</p> <p>45</p> <p>1=1 VIS231</p>														
<p>VA x11</p> <p>CHE02</p>	<p>VV x11</p> <p>RON34</p>	<p>AU x2</p> <p>Lg=1940mm 6210-01</p>													
<p>AA x1</p> <p>Lg=1972mm 6189-01</p>	<p>AS x1</p> <table border="1" data-bbox="658 1085 1075 1300"> <thead> <tr> <th colspan="2">6209</th> </tr> <tr> <th>● Longueur ● Length ● Largo</th> <th>● Lunghezza ● Lengte ● Länge</th> </tr> </thead> <tbody> <tr> <td>100</td> <td>Lg=950mm</td> </tr> <tr> <td>120</td> <td>Lg=1150mm</td> </tr> <tr> <td>140</td> <td>Lg=1350mm</td> </tr> <tr> <td>160</td> <td>Lg=1550mm</td> </tr> <tr> <td>170</td> <td>Lg=1650mm</td> </tr> </tbody> </table>	6209		● Longueur ● Length ● Largo	● Lunghezza ● Lengte ● Länge	100	Lg=950mm	120	Lg=1150mm	140	Lg=1350mm	160	Lg=1550mm	170	Lg=1650mm
6209															
● Longueur ● Length ● Largo	● Lunghezza ● Lengte ● Länge														
100	Lg=950mm														
120	Lg=1150mm														
140	Lg=1350mm														
160	Lg=1550mm														
170	Lg=1650mm														
<p>AB 120/140/160/170 x1 100 x0</p> <p>Lg=1972mm 6190-01</p>	<p>AT x1</p> <table border="1" data-bbox="694 1404 1075 1548"> <thead> <tr> <th colspan="2">6209</th> </tr> <tr> <th>● Largeur ● Width ● Ancho</th> <th>● Larghezza ● Breedte ● Breite</th> </tr> </thead> <tbody> <tr> <td>70</td> <td>Lg=635mm</td> </tr> <tr> <td>80</td> <td>Lg=735mm</td> </tr> <tr> <td>90</td> <td>Lg=835mm</td> </tr> </tbody> </table>	6209		● Largeur ● Width ● Ancho	● Larghezza ● Breedte ● Breite	70	Lg=635mm	80	Lg=735mm	90	Lg=835mm				
6209															
● Largeur ● Width ● Ancho	● Larghezza ● Breedte ● Breite														
70	Lg=635mm														
80	Lg=735mm														
90	Lg=835mm														

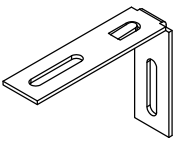
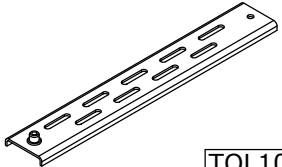
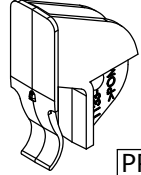
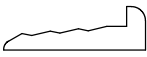
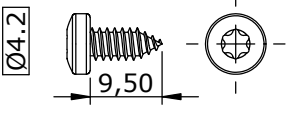
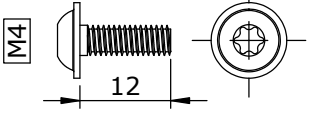
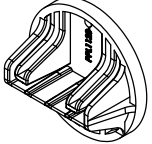
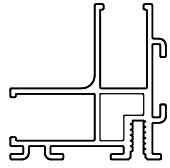

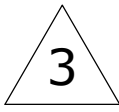
<p>TE 120/140/160/170 x6 100 x4</p>  <p>TOL102</p>	<p>TF 120/140/160/170 x6 100 x4</p>  <p>TOL103</p>	<p>PAA 120/140/160/170 x5 100 x4</p>  <p>PPL1133</p>
<p>JG 120/140/160/170 x6 100 x4</p>  <p>Lg=1971mm P101</p>	<p>VQ 120/140/160/170 x5 100 x4</p>  <p>1=1 VIS238</p>	<p>VR 120/140/160/170 x6 100 x4</p>  <p>1=1 VIS239</p>
<p>PAL 120/140/160/170 x1 100 x0</p>  <p>PPL1128</p>	<p>AA x1</p>  <p>Lg=1972mm 6189-01</p>	

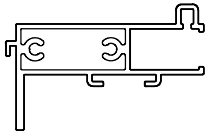

<p>AO x1</p>  <p>Lg=1944mm 6204-01</p>	<p>JG x1</p>  <p>Lg=1971mm P101</p>
---	--

4

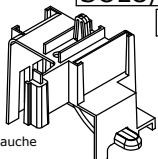
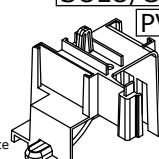
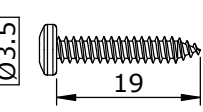
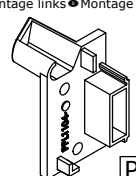
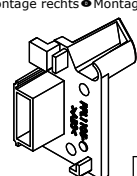
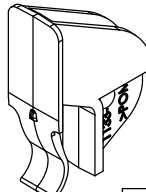
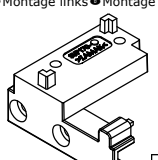
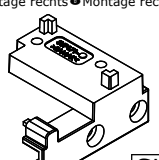
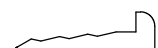
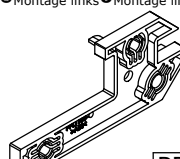
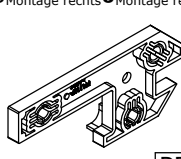
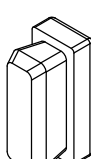
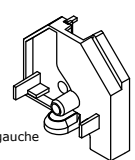
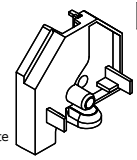
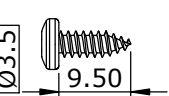
<p>SA</p> <p>SOLO/CLT x1 PVT x0</p>  <ul style="list-style-type: none"> ● Montage gauche ● Left hand ● Montaje a la izquierda ● Montaggio a sinistra ● Montage links ● Montage links <p>SET107</p>	<p>SB</p> <p>SOLO/CLT x1 PVT x0</p>  <ul style="list-style-type: none"> ● Montage droite ● Right hand ● Montaje a la derecha ● Montaggio a destra ● Montage rechts ● Montage rechts <p>SET108</p>	<p>VM</p> <p>CLT/RID x8 SOLO x9</p>  <p>1=1 VIS215</p>
<p>PI</p> <ul style="list-style-type: none"> ● Montage gauche ● Left hand ● Montaje a la izquierda ● Montaggio a sinistra ● Montage links ● Montage links  <p>PPL1104</p>	<p>PJ</p> <ul style="list-style-type: none"> ● Montage droite ● Right hand ● Montaje a la derecha ● Montaggio a destra ● Montage rechts ● Montage rechts  <p>PPL1105</p>	<p>PAA</p>  <p>PPL1133</p>
<p>SI</p> <ul style="list-style-type: none"> ● Montage gauche ● Left hand ● Montaje a la izquierda ● Montaggio a sinistra ● Montage links ● Montage links  <p>SUP170</p>	<p>SJ</p> <ul style="list-style-type: none"> ● Montage droite ● Right hand ● Montaje a la derecha ● Montaggio a destra ● Montage rechts ● Montage rechts  <p>SUP171</p>	<p>JG</p>  <p>Lg=1971mm P101</p>
<p>PK</p> <ul style="list-style-type: none"> ● Montage gauche ● Left hand ● Montaje a la izquierda ● Montaggio a sinistra ● Montage links ● Montage links  <p>PPL1106</p>	<p>PL</p> <ul style="list-style-type: none"> ● Montage droite ● Right hand ● Montaje a la derecha ● Montaggio a destra ● Montage rechts ● Montage rechts  <p>PPL1107</p>	<p>QC</p>  <p>BUT22</p>
<p>PV</p> <p>SOLO/PVT x1 CLT x0</p>  <ul style="list-style-type: none"> ● Montage gauche ● Left hand ● Montaje a la izquierda ● Montaggio a sinistra ● Montage links ● Montage links <p>PPL1126</p>	<p>PW</p> <p>SOLO/PVT x1 CLT x0</p>  <ul style="list-style-type: none"> ● Montage droite ● Right hand ● Montaje a la derecha ● Montaggio a destra ● Montage rechts ● Montage rechts <p>PPL1127</p>	<p>VP</p> <p>SOLO/CLT/RID x3 PVT x2</p>  <p>1=1 VIS237</p>

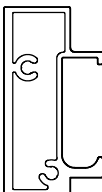
AG  x1

6196	
● Longueur ● Length ● Largo	● Lunghezza ● Lengte ● Länge
100	Lg=880mm
120	Lg=1080mm
140	Lg=1280mm
160	Lg=1480mm
170	Lg=1580mm

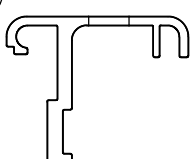
AD  x1

6194		
● Longueur ● Length ● Largo	CLT	SOLO / 2P
● Lunghezza ● Lengte ● Länge		
100	Lg=456mm	Lg=673mm
120	Lg=556mm	Lg=506mm
140	Lg=656mm	Lg=606mm
160	Lg=756mm	Lg=706mm
170	Lg=806mm	Lg=706mm

AJ  x1

6199		
● Longueur ● Length ● Largo	CLT	SOLO / 2P
● Lunghezza ● Lengte ● Länge		
100	Lg=401mm	Lg=183mm
120	Lg=501mm	Lg=383mm
140	Lg=601mm	Lg=751mm
160	Lg=701mm	Lg=851mm
170	Lg=751mm	Lg=851mm

AQ  x2

Lg=300mm 6206-01

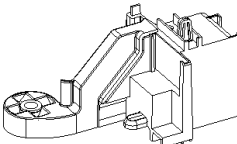
SM 

- Montage gauche ● Left hand
- Montaje a la izquierda
- Montaggio a sinistra
- Montage links ● Montage links

PVT: x1

CLT: x0

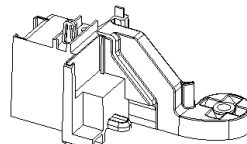
SET115 

- Montage droite ● Right hand
- Montaje a la derecha
- Montaggio a destra
- Montage rechts ● Montage rechts

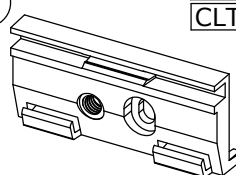
PF  x4

PVT x4

CLT x0

PPL1099

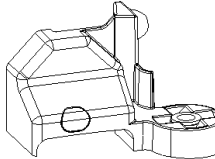
SN 

- Montage gauche ● Left hand
- Montaje a la izquierda
- Montaggio a sinistra
- Montage links ● Montage links

PVT: x1

CLT: x0

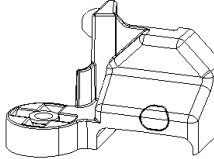
SET114 

- Montage droite ● Right hand
- Montaje a la derecha
- Montaggio a destra
- Montage rechts ● Montage rechts

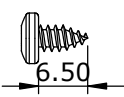
VO  x4

Ø3.5 PVT x4

CLT x0

6.50

1=1 VIS234

Ø3.5

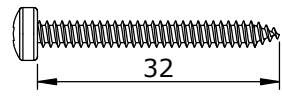
VAA  x1

Ø3.5 PVT x1

CLT x0

32

1=1 VIS214

5 CLT

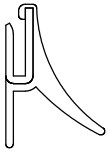
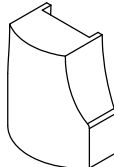
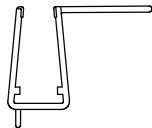
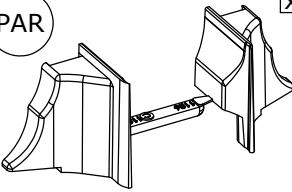
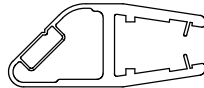
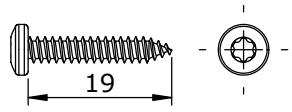
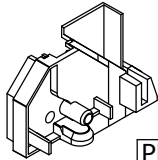
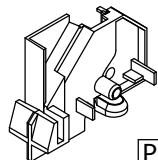
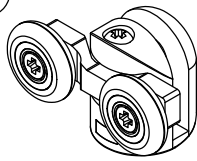
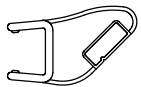
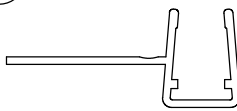
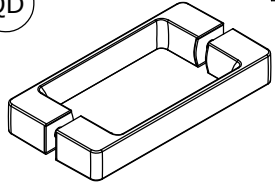
<p>JE x1</p>  <p>Lg=820mm JOI239</p>	<p>PC x1</p>  <p>PPL823</p>	<p>JC x1</p>  <p>Lg=1882mm J723</p>
<p>PAR x1</p>  <p>PPL1136/1137</p>	<p>JB x1</p>  <p>Lg=1959mm AI150</p>	<p>VM x1</p> <p style="text-align: center;">Ø3.5</p>  <p style="text-align: center;">19</p> <p>1=1 VIS215</p>
<p>PO x1</p> <ul style="list-style-type: none"> ● Montage gauche ● Left hand ● Montaje a la izquierda ● Montaggio a sinistra ● Montage links ● Montage links  <p>PPL1110</p>	<p>PP x1</p> <ul style="list-style-type: none"> ● Montage droite ● Right hand ● Montaje a la derecha ● Montaggio a destra ● Montage rechts ● Montage rechts  <p>PPL1111</p>	<p>QE x2</p>  <p>ROU19</p>
<p>JA x1</p>  <p>Lg=1975mm AI113</p>	<p>JD x1</p>  <p>Lg=1894mm J719</p>	<p>QD x1</p>  <p>PGN36</p>

5 PVT

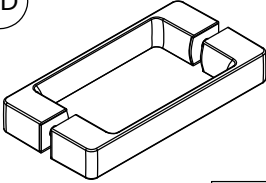
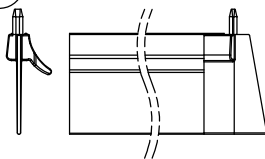
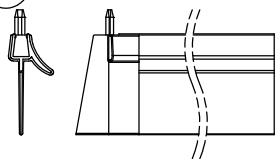
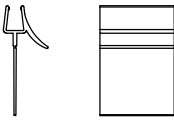
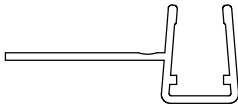
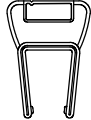
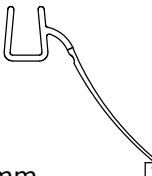
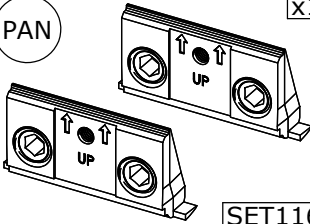
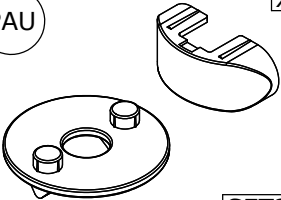
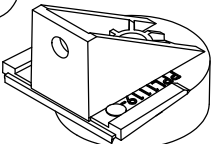
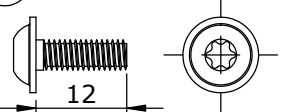
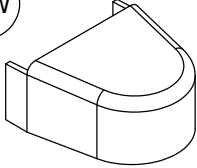
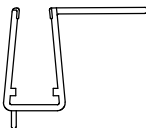
<p>QD x2</p>  <p>PGN36</p>	<p>JR x1</p>  <p>Lg=284mm</p> <p>J761</p>	<p>JS x1</p>  <p>Lg=284mm</p> <p>J762</p>
<p>JT x2</p>  <p>Lg=27mm</p> <p>J763</p>	<p>JV x1</p>  <p>JOI249</p>	<p>JP x2</p>  <p>Lg=1900mm</p> <p>AI074</p>
<p>JU x1</p>  <p>Lg=1940mm</p> <p>J764</p>	<p>PAN x1</p>  <p>SET116</p>	<p>PAU x4</p>  <p>SET29</p>
<p>PAV x2</p>  <p>PPL1119</p>	<p>VR M4 x2</p>  <p>12</p> <p>1=1</p> <p>VIS239</p>	<p>PAW x2</p>  <p>PPL1120</p>
<p>JC x1</p>  <p>Lg=1882mm</p> <p>J723</p>		

6

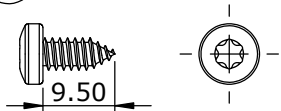
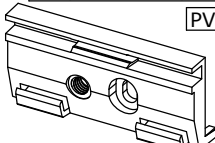
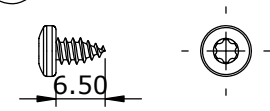
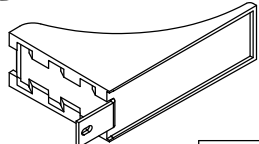
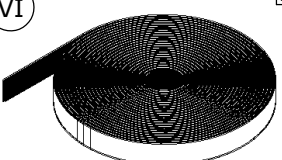
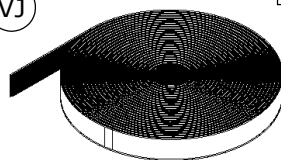
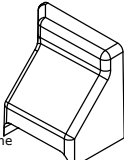
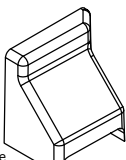
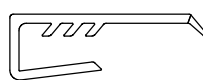
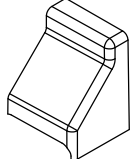
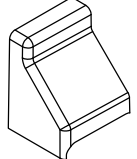
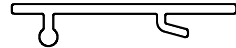
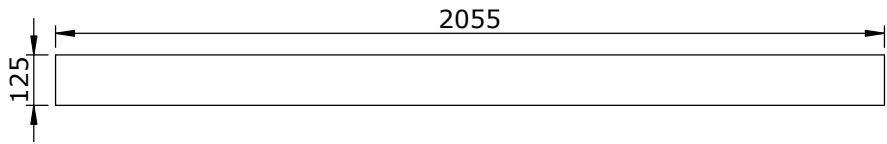
<p>VQ $\varnothing 4.2$ x6</p>  <p>9.50</p> <p>1=1 VIS238</p>	<p>PF CLT/SOLO:140/160/170 x4 CLT/SOLO:100/120 x3 PVT x0</p>  <p>PPL1099</p>	<p>VO $\varnothing 3.5$ x9</p>  <p>6.50</p> <p>1=1 VIS253</p>
<p>PAK 140/160/170 x5 100/120 x3</p>  <p>SET105</p>	<p>VI x3</p>  <p>Lg=2800mm VEL06-5</p>	<p>VJ x3</p>  <p>Lg=2800mm VEL06-6</p>
<p>SG CLT x1 PVT x0</p>  <p>● Montage gauche ● Left hand ● Montaje a la izquierda ● Montaggio a sinistra ● Montage links ● Montage links</p> <p>SUP168</p>	<p>SH CLT x1 PVT x0</p>  <p>● Montage droite ● Right hand ● Montaje a la derecha ● Montaggio a destra ● Montage rechts ● Montage rechts</p> <p>SUP169</p>	<p>JJ x2</p>  <p>Lg=2200mm PFL84</p>
<p>SP ● Montage gauche ● Left hand ● Montaje a la izquierda ● Montaggio a sinistra ● Montage links ● Montage links</p> <p>PVT x1 CLT x0</p>  <p>SET118</p>	<p>● Montage droite ● Right hand ● Montaje a la derecha ● Montaggio a destra ● Montage rechts ● Montage rechts</p> 	<p>AE x1</p>  <p>Lg=2030mm 6195-01</p>
<p>FA x1</p>  <p>2055</p> <p>125</p> <p>PUS132</p>		

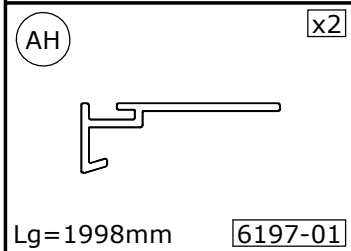
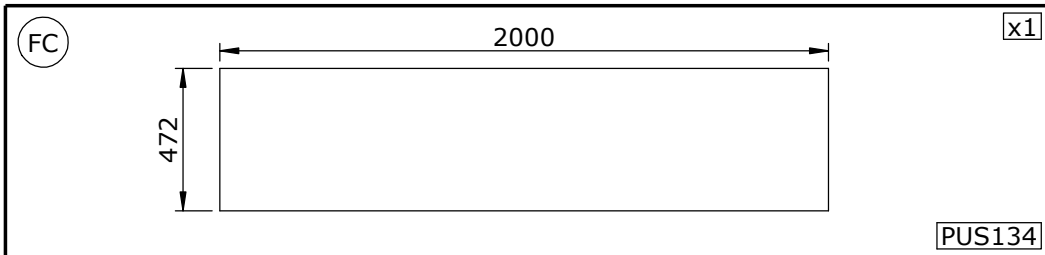

- Les quantités données sont les quantités utiles au montage. les sachets fournis contiennent des pièces supplémentaires.
- The quantities given are what are required for the installation. There may be some surplus in the package provide.
- Las cantidades indicadas son las cantidades necesarias para el montaje. Las bolsitas incluidas contienen piezas suplementarias.
- Le quantità fornite sono le quantità necessarie al montaggio. I sacchetti forniti contengono pezzi supplementari.
- De aangegeven aantallen zijn vereist voor de montage. De verpakking bevat extra onderdelen.
- Die Mengenangaben beziehen sich auf die für die Montage nötigen Teile. Eventuell weitere beige packte Teile ignorieren.

● Outillage nécessaire ● Tools required ● Equipamiento necesario
 ● Attrezzatura necessaria ● Benodigde gereedschap ● Werkzeuge erforderlich

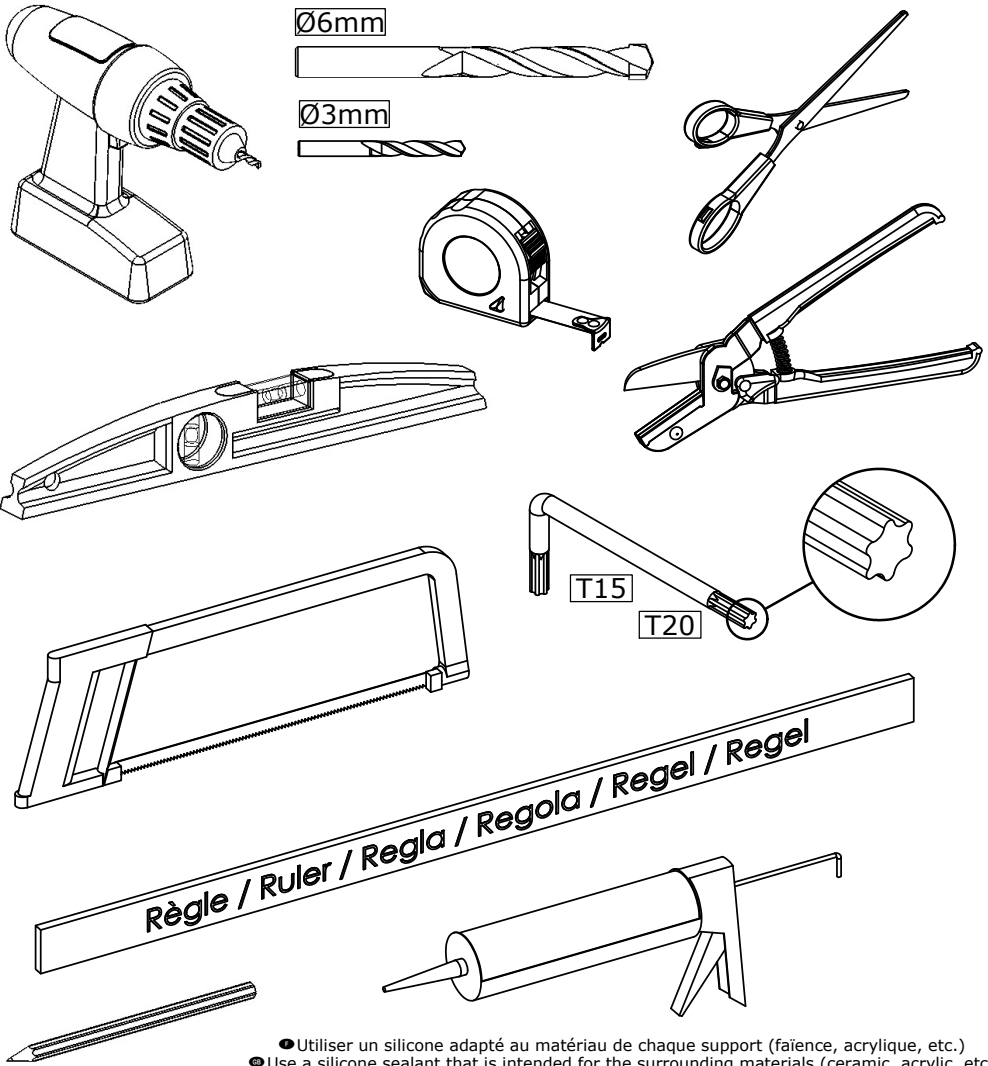

- Utiliser un silicone adapté au matériau de chaque support (faïence, acrylique, etc.)
- Use a silicone sealant that is intended for the surrounding materials (ceramic, acrylic, etc.)
 - Usar una silicona adecuada para cada tipo de material (loza, acrílico, etc.)
 - Utilizzare un silicone adatto a qualsiasi materiale (ceramica, acrilico, ecc.)
 - Gebruik siliconenkit die geschikt is voor iedere ondergrond (tegelwerk, acryl, etc.)
 - Für das jeweilige Trägermaterial (Stein, Acryl usw.) geeignetes Silikon verwenden.



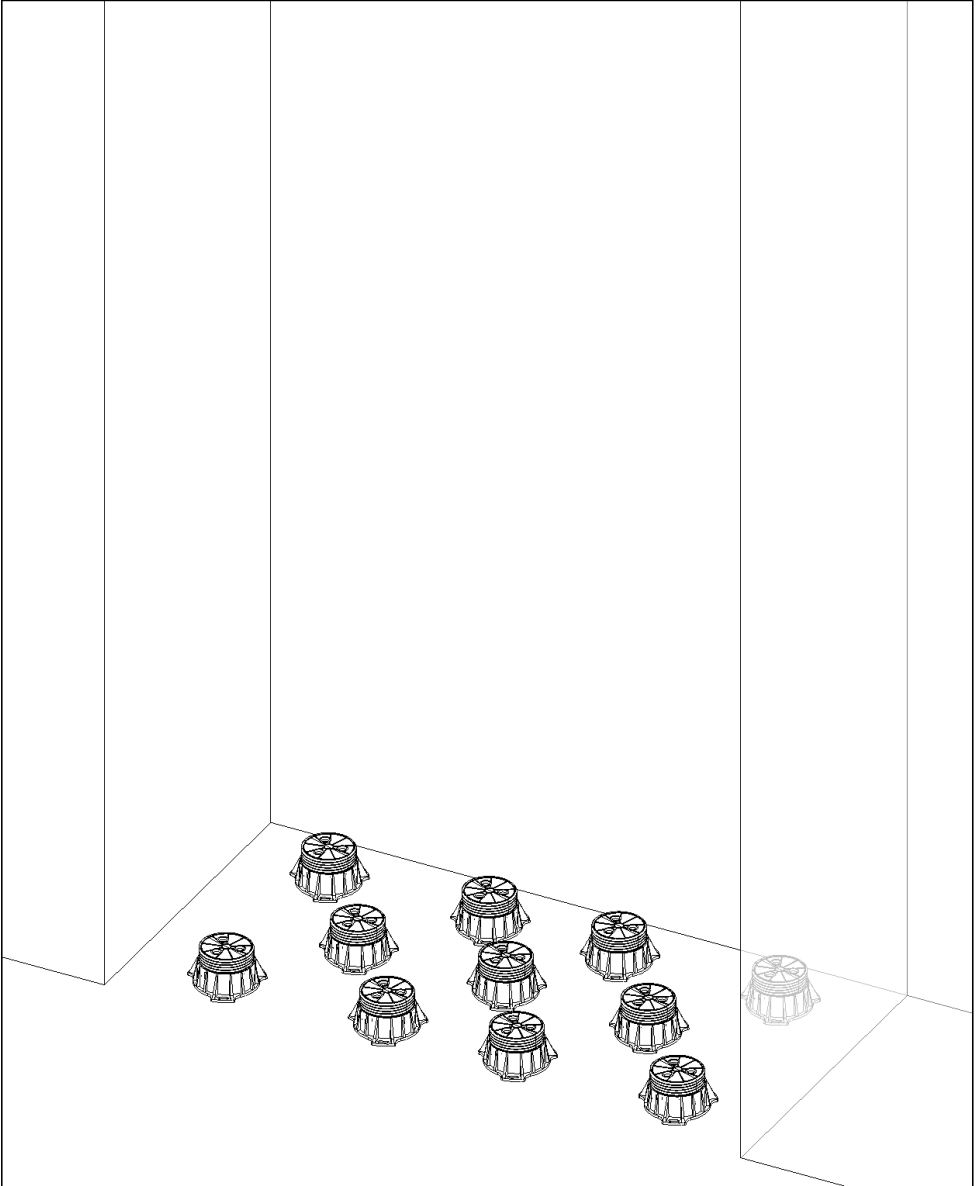
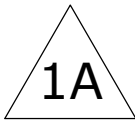

1B

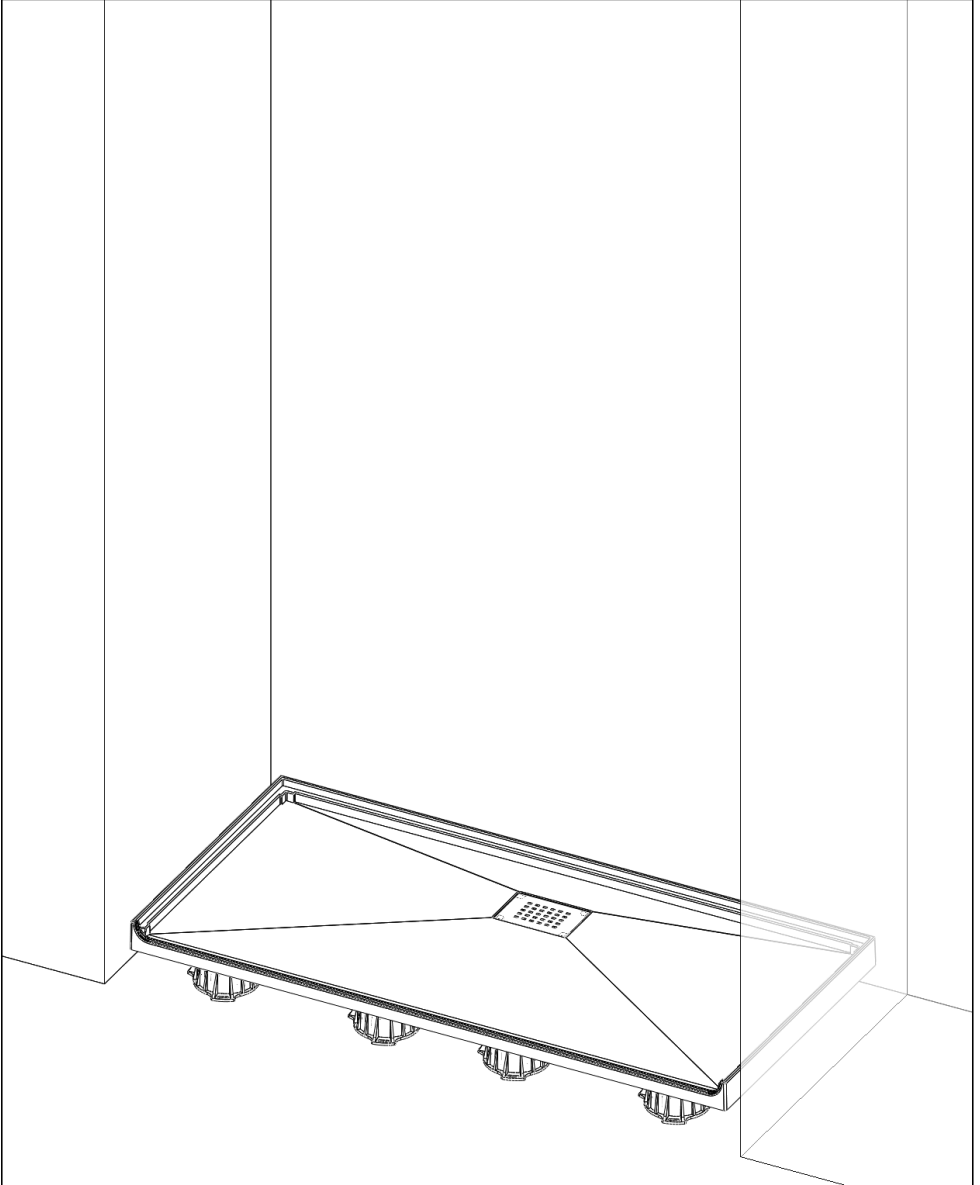

1C

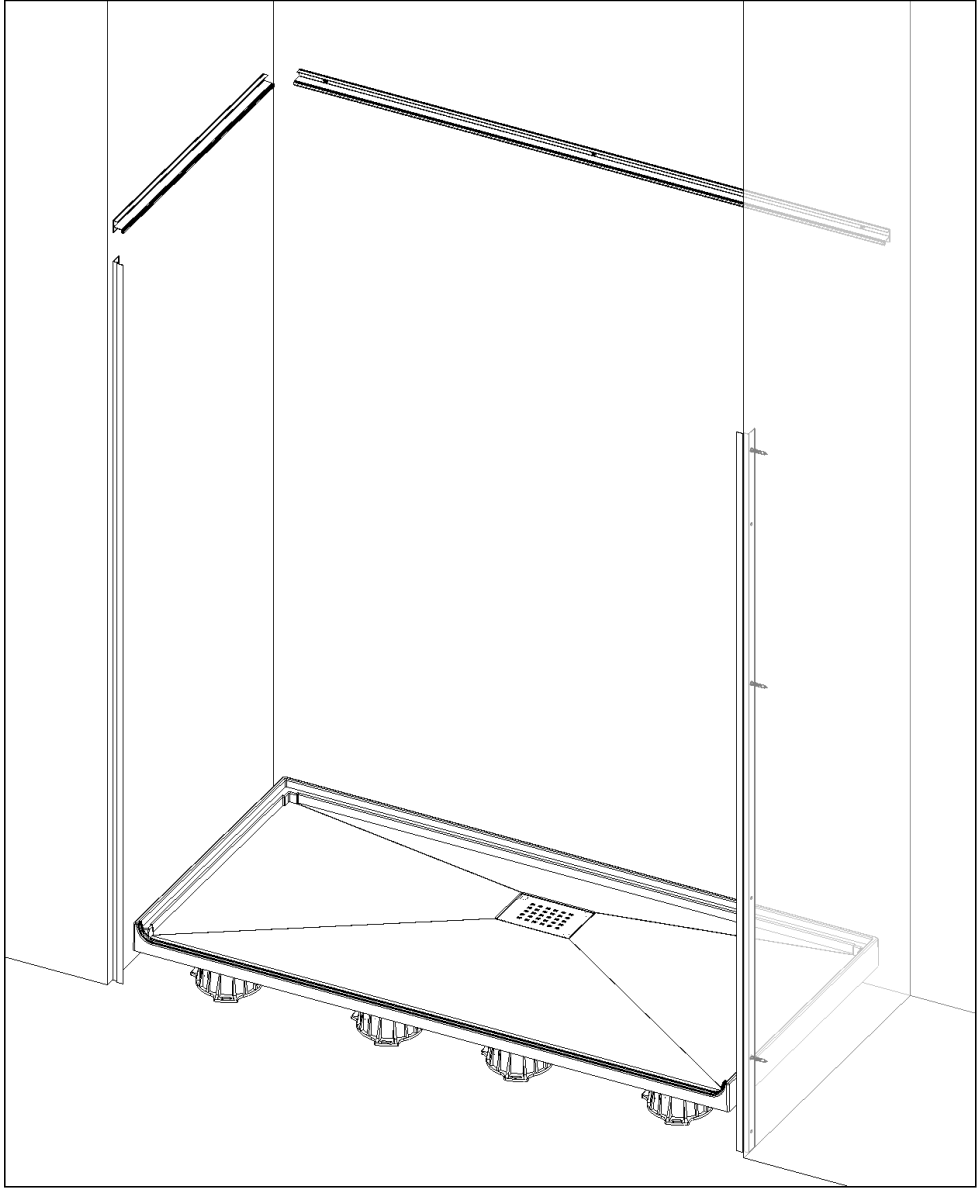

2

2

2A

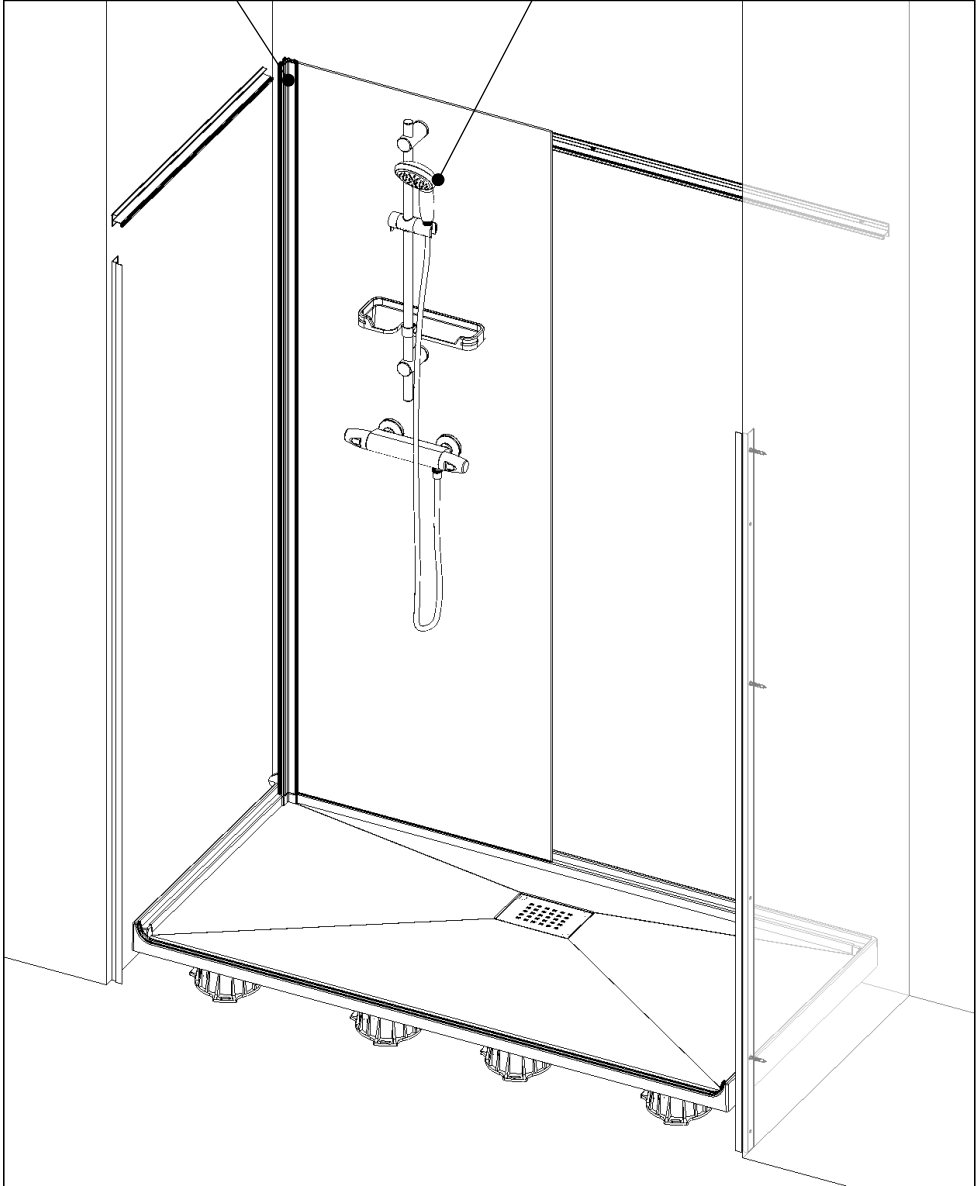

2

2

2B

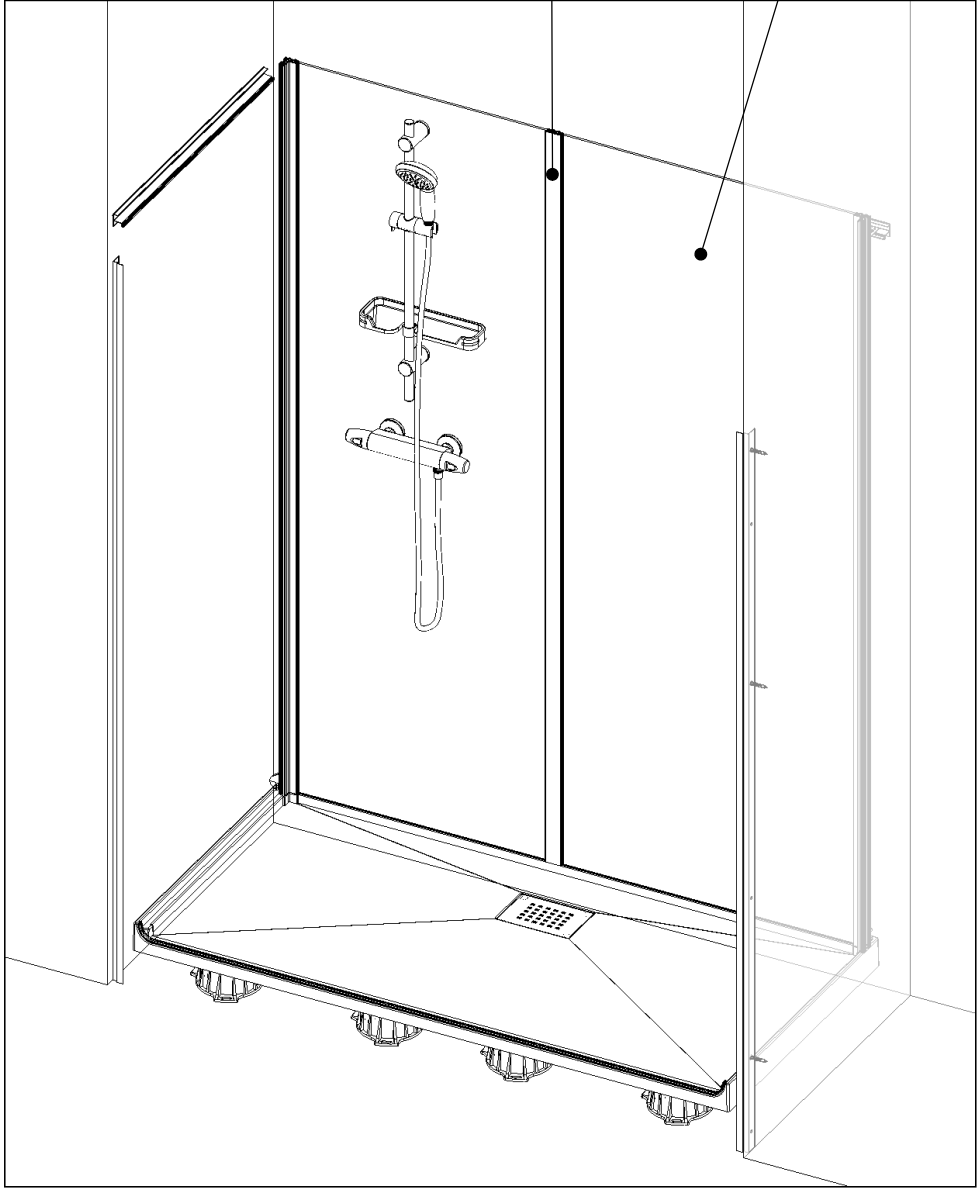

2

2C

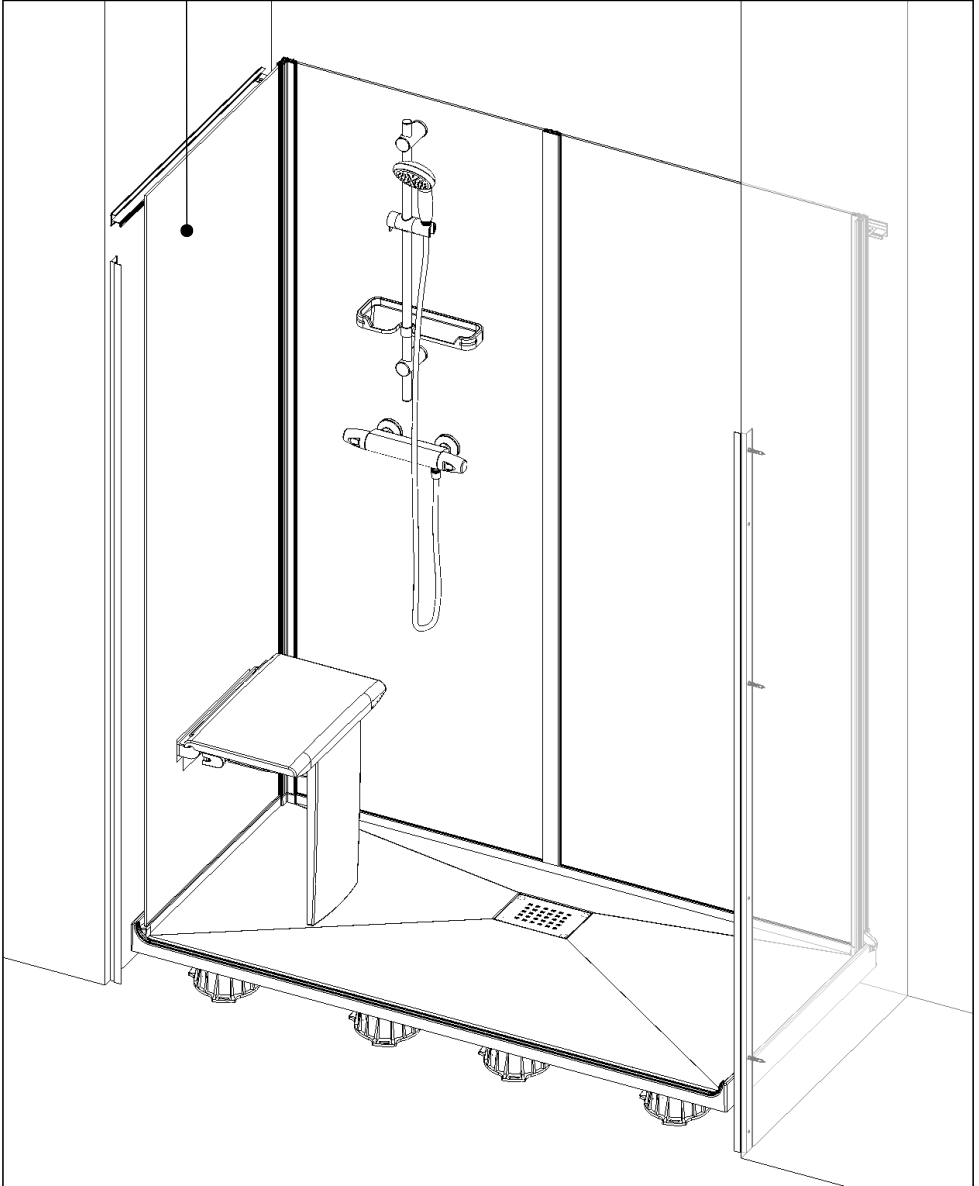

3

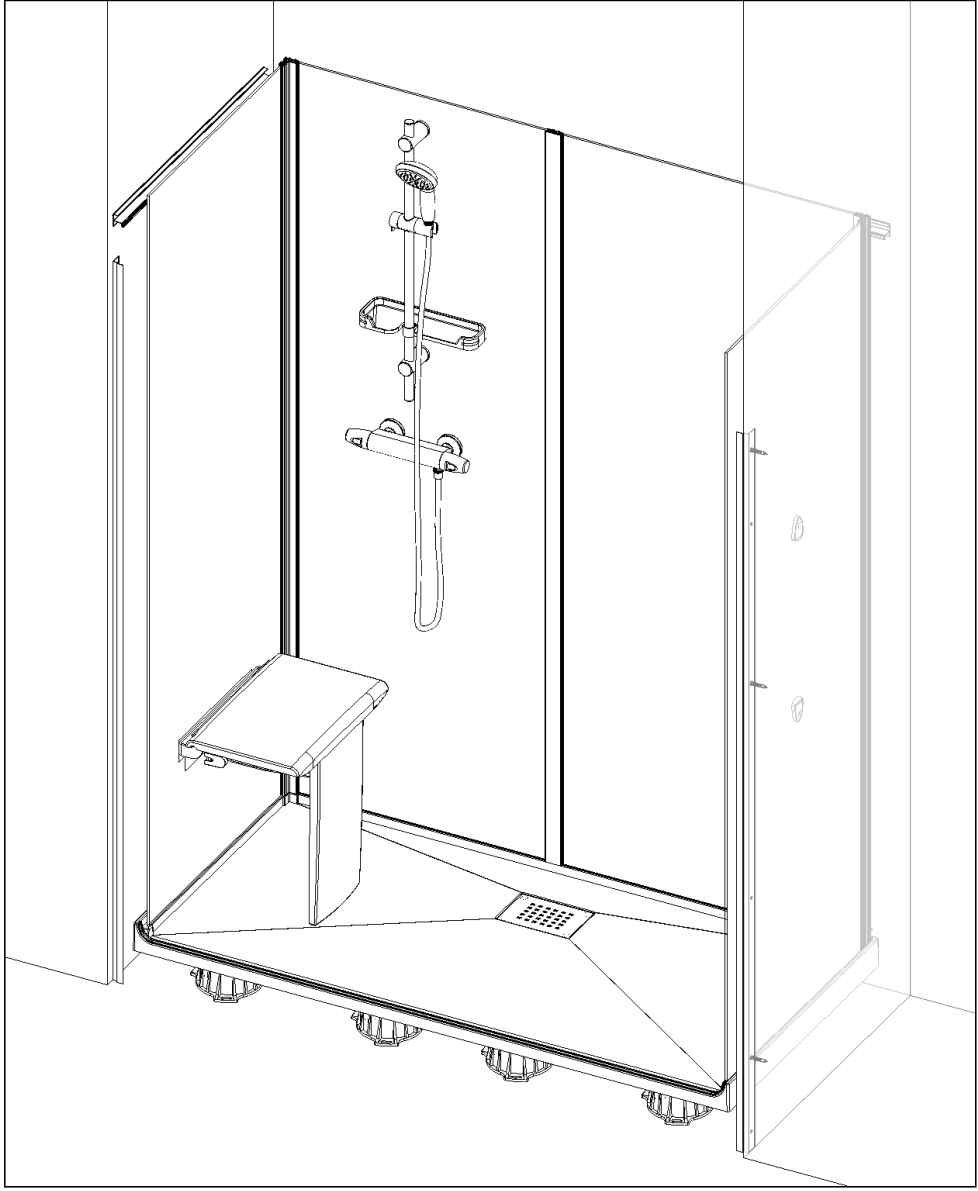

4

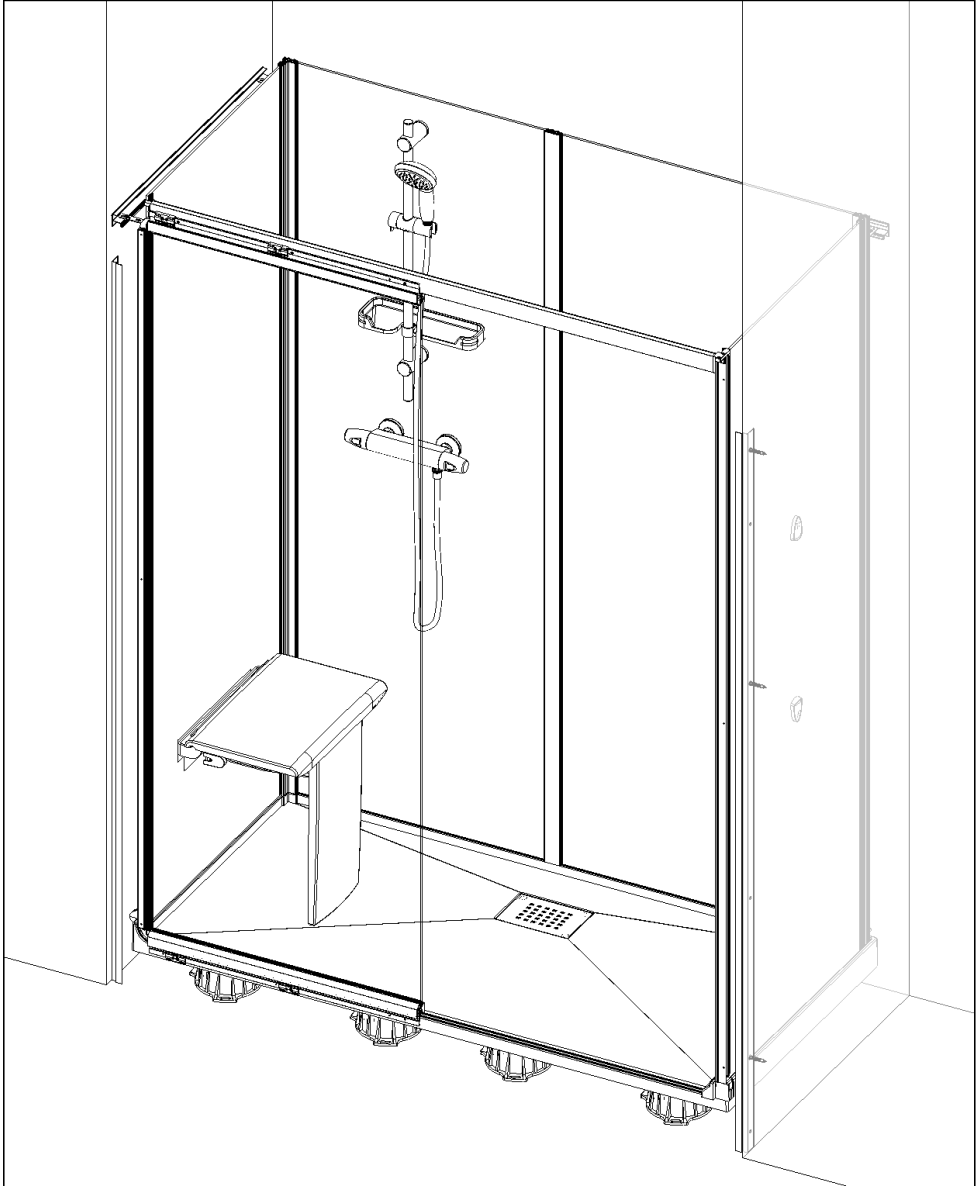

- En cas de montage solo ● In case of mounting without door
- En caso de montaje con mampara fija
- In caso di montaggio senza porta
- Bij montage uitvoering solo ● Bei Montage Ohne Tür

=>



CLT

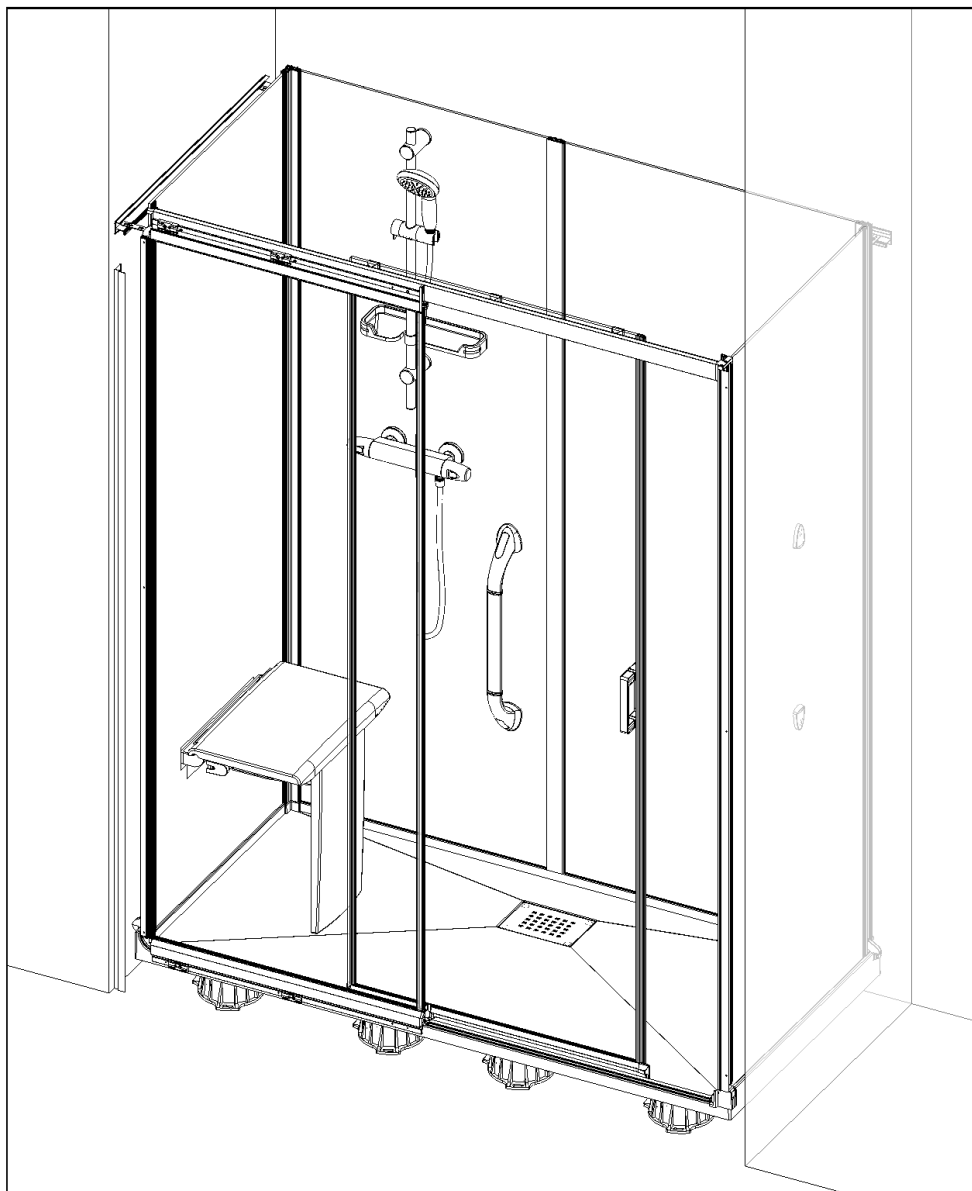

- En cas de montage solo ● In case of mounting without door
- En caso de montaje con mampara fija
- In caso di montaggio senza porta
- Bij montage uitvoering solo ● Bei Montage Ohne Tür

=>

6

5 PVT

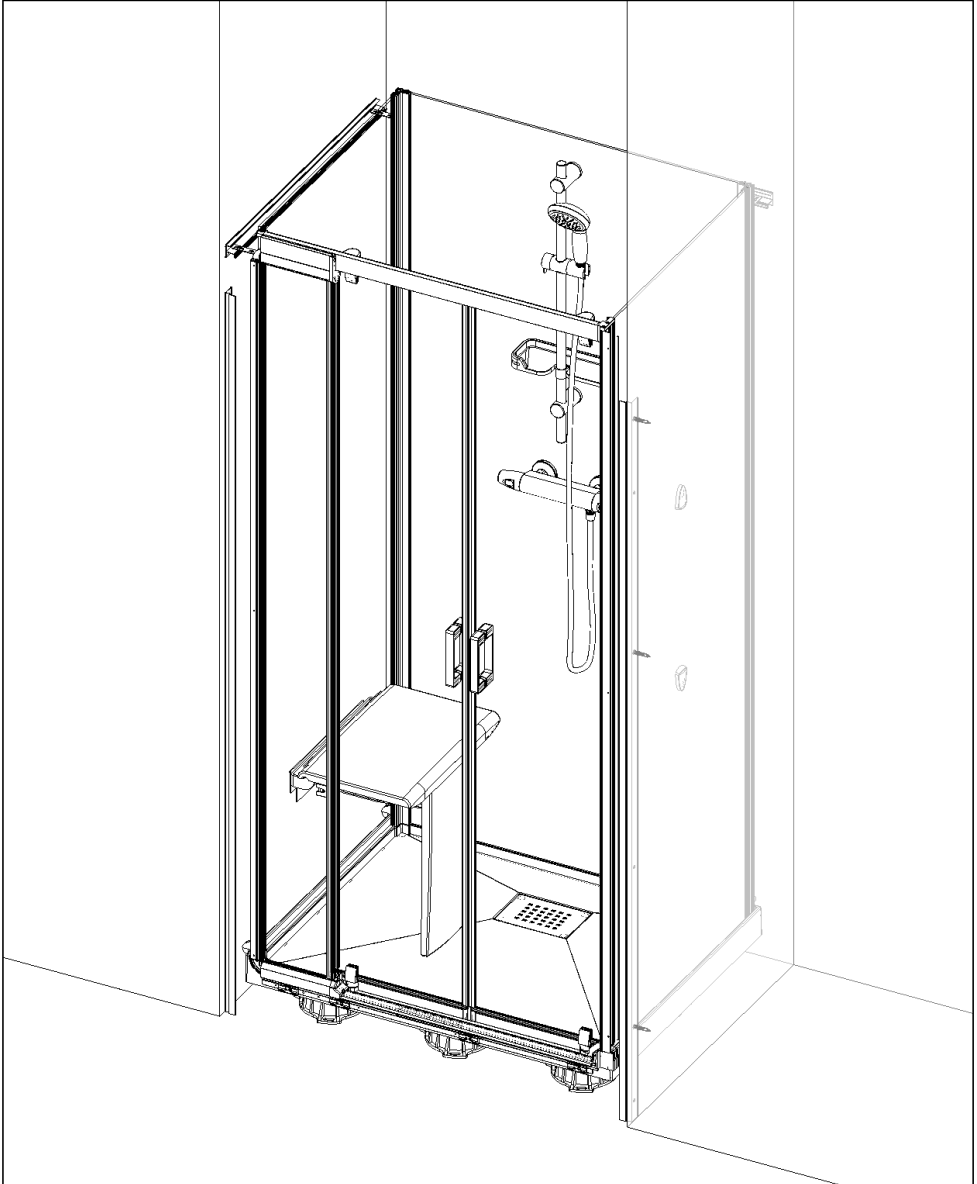

6

- Voir notice concernée
- Ver manual adecuado
- Zie montage-instructies
- See installation instructions required
- Vedere manuale appropriato
- Siehe betreffende Anleitung

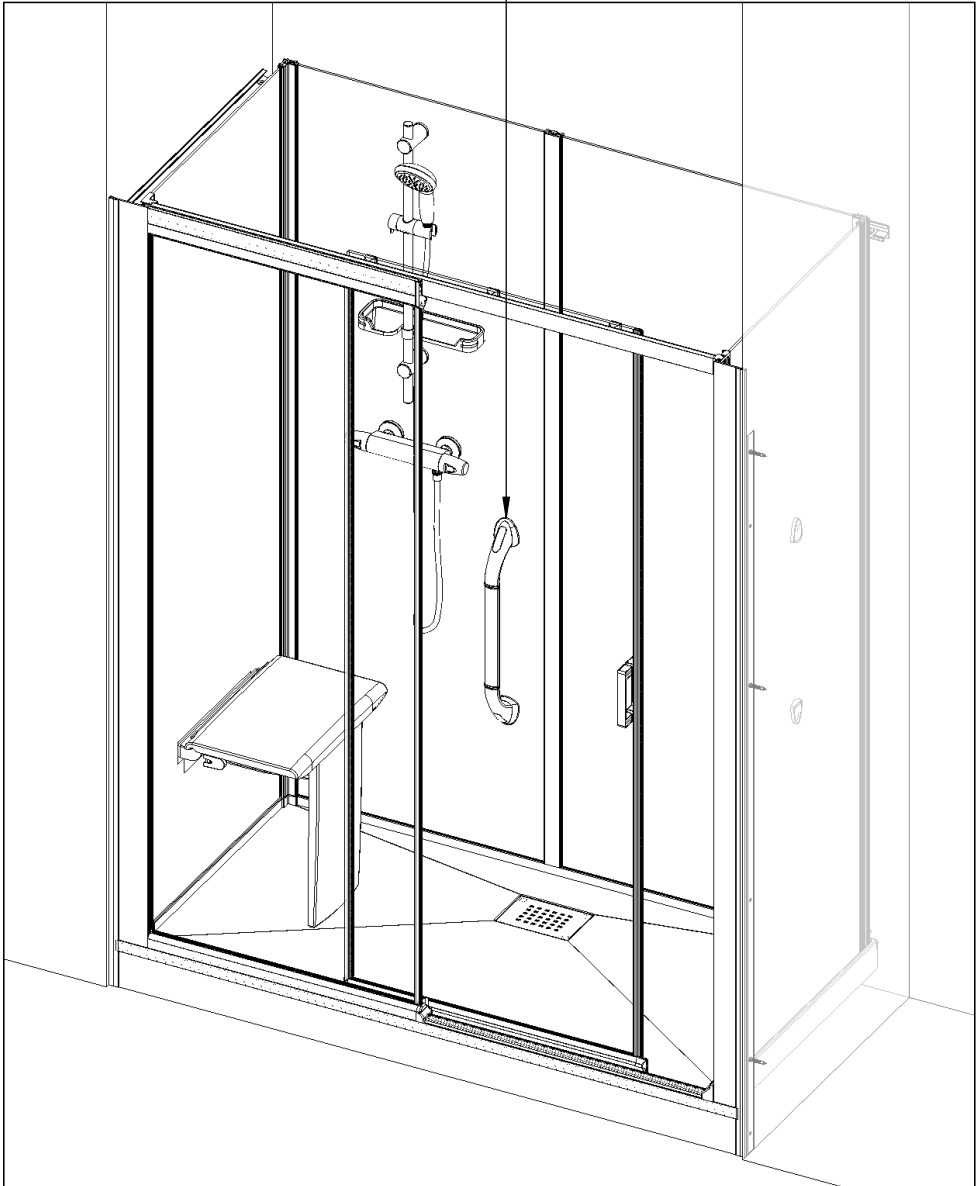

- Zone de décaissement pour un montage de receveur sans pieds
- Area required for the installation of the tray without feet
- Zona rebajada para la instalación del plato sin pies
- Zone necessarie per un montaggio del piatto senza piedi
- Aflooplegebied voor de montage van een douchebak zonder poten
- Freier Raum für Montage der Duschanne ohne FüÙe

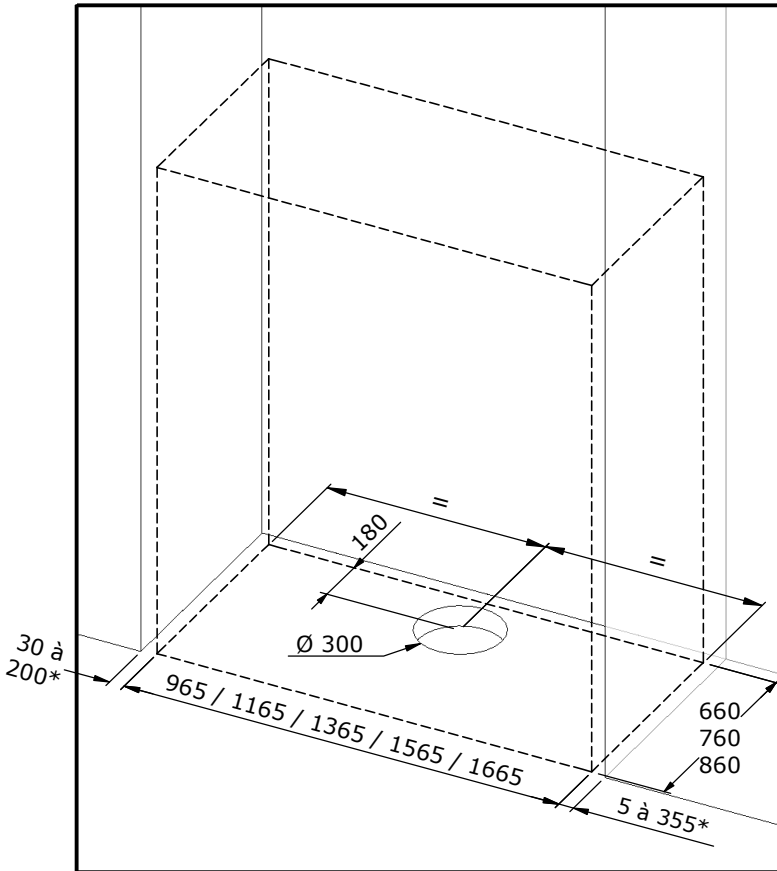

- *● Côté gauche et droit cumulés ne peuvent excéder 385 mm.
- Left and right sides summed must not exceed 385 mm.
- Las cuotas agregadas izquierda y derecha no pueden superar 385 mm.
- Sinistra e destra combinati non possono superare 385 mm.
- De linker- en rechterzijde mogen samen niet groter zijn dan 385 mm.
- Links und rechts dürfen es zusammen nicht mehr als 385 mm sein.

● Cotes en mm ● Dimensions in mm ● Cotas en mm

● Quote in mm ● Afmetingen in mm ● Maße sind in mm angegeben

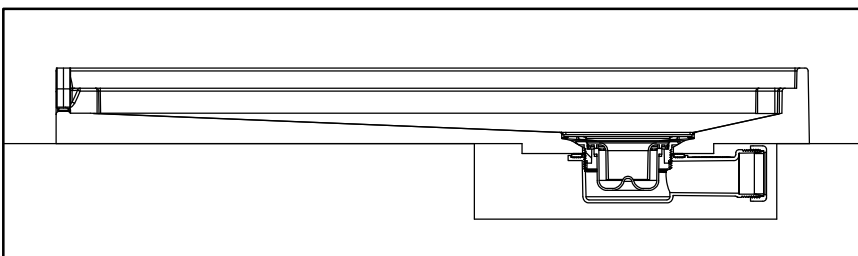



SERVICE APRÈS-VENTE AFTER-SALES SERVICE

FRANCE

+33 (0)2 40 21 29 45

UK

+44 (0)20 8842 0033

IRELAND

+353 04697 33102

DEUTSCHLAND

+49 (0) 6074 / 30928 0

ITALIA

+39 (0382) 6181

ÖSTEREICH

+43 1 710 60 70

SUISSE/SCHWEIZ

+41 (0)32 631 04 74

ESPAÑA

+34 93 544 60 76

NEDERLAND

+31 475 487 100

BELGIQUE/BELGIË

+31 475 487 100

РОССИЯ

+7 495 258-29-51

PORTUGAL

+351 219 112 785