

Notice de montage - Installation instructions  
Manual de instalación - Manual de instalação -  
Istruzioni di montaggio  
Montage-instructies - Montageanleitung

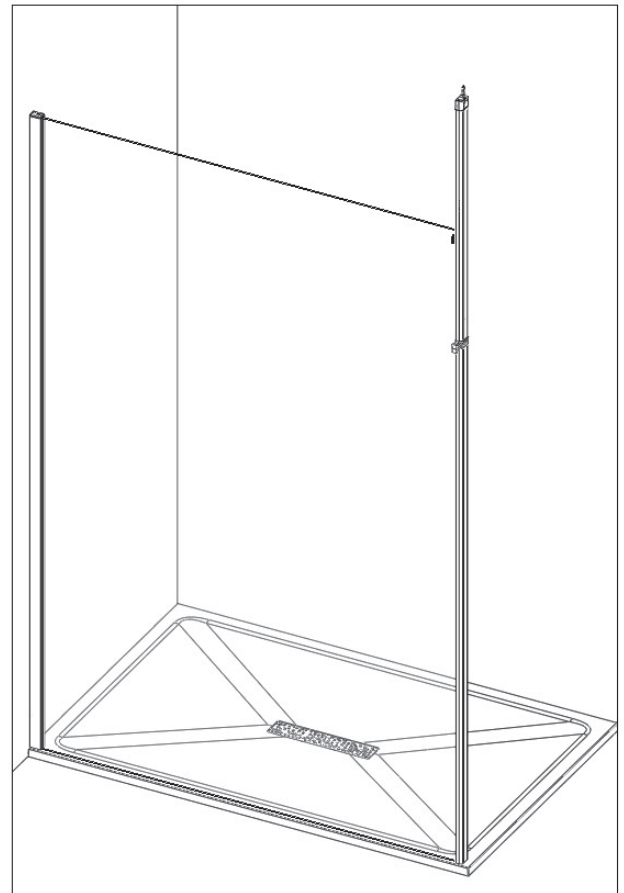

Attention aux étapes :  
Check installation steps :  
Atención a los pasos:  
Atenção aos passos:  
Attenzione ai passi :  
Aandacht voor de stappen :  
Achtung vor den Schritten :

**P.7 - P.11**

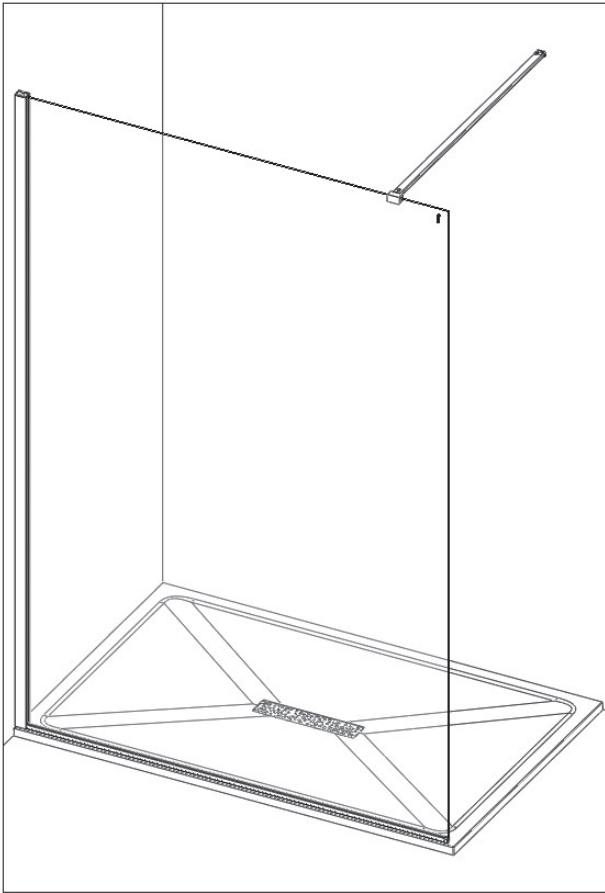
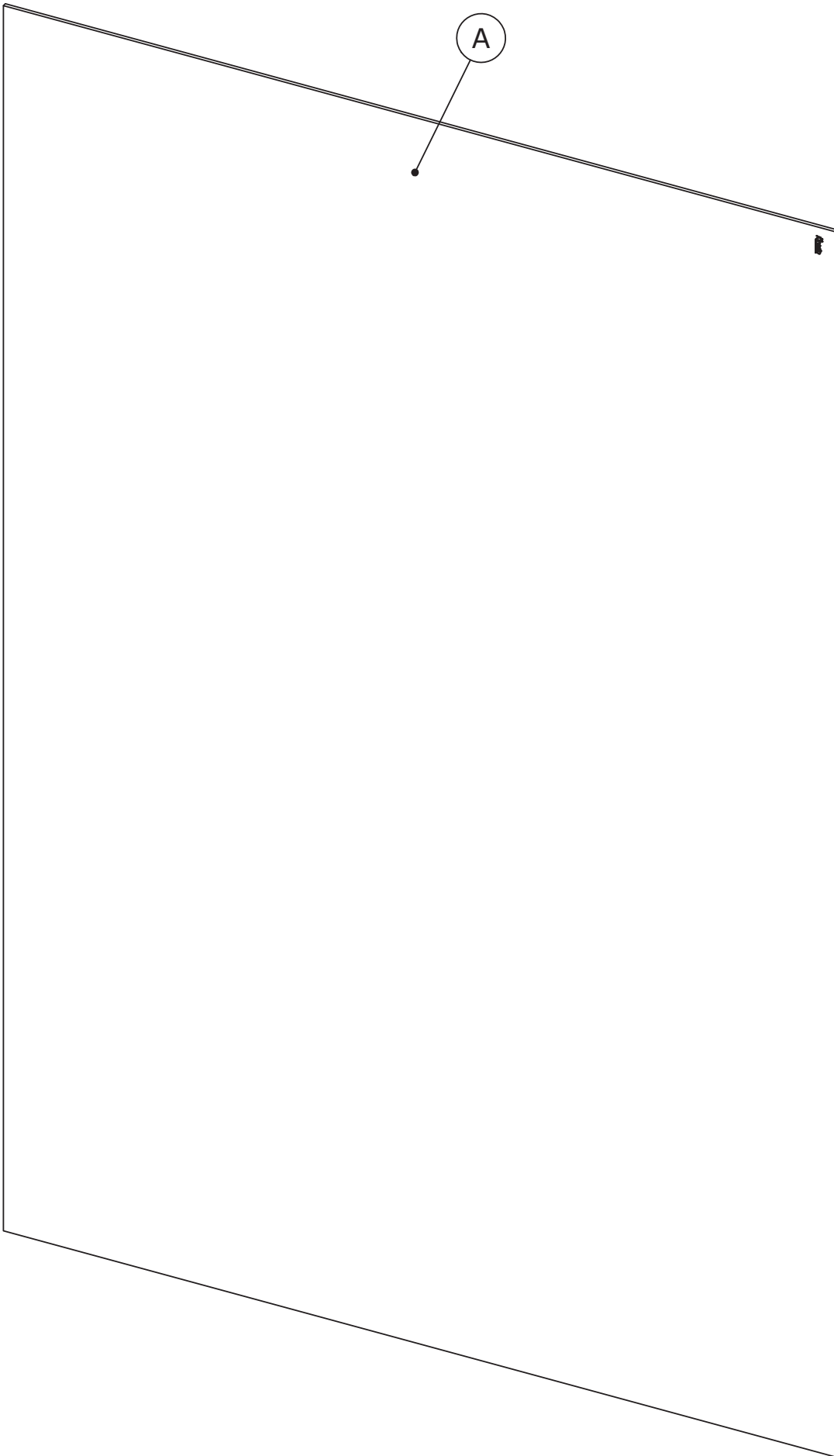

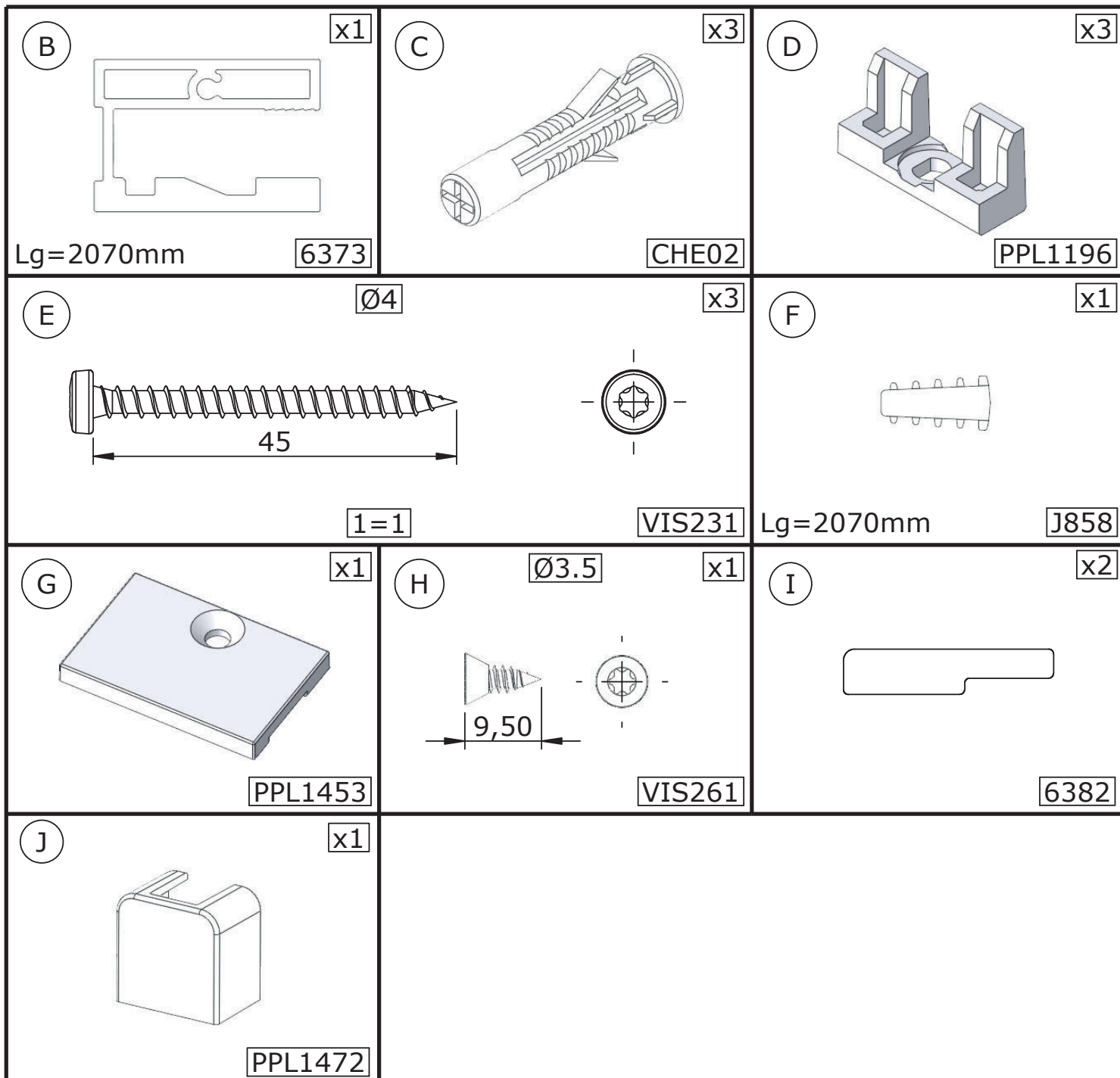

Les quantités données sont les quantités utiles au montage. les sachets fournis contiennent des pièces supplémentaires.

The quantities given are what are required for the installation. There may be some surplus in the package provide.

Las cantidades indicadas son las cantidades necesarias para el montaje. Las bolsitas incluidas contienen piezas suplementarias.

As quantidades indicadas são as quantidades necessárias para a montagem. Os sacos fechados contêm peças adicionais.

Le quantità fornite sono le quantità necessarie al montaggio. I sacchetti forniti contengono pezzi supplementari.

De aangegeven aantallen zijn vereist voor de montage. De verpakking bevat extra onderdelen.

Die Mengenangaben beziehen sich auf die für die Montage nötigen Teile. Eventuell weitere beige packte Teile ignorieren.

Matériel nécessaire - Tools required  
 Equipamiento necesario - Equipamento necessário  
 Materiale necessario - Benodigd gereedschap - Benötigte Werkzeuge

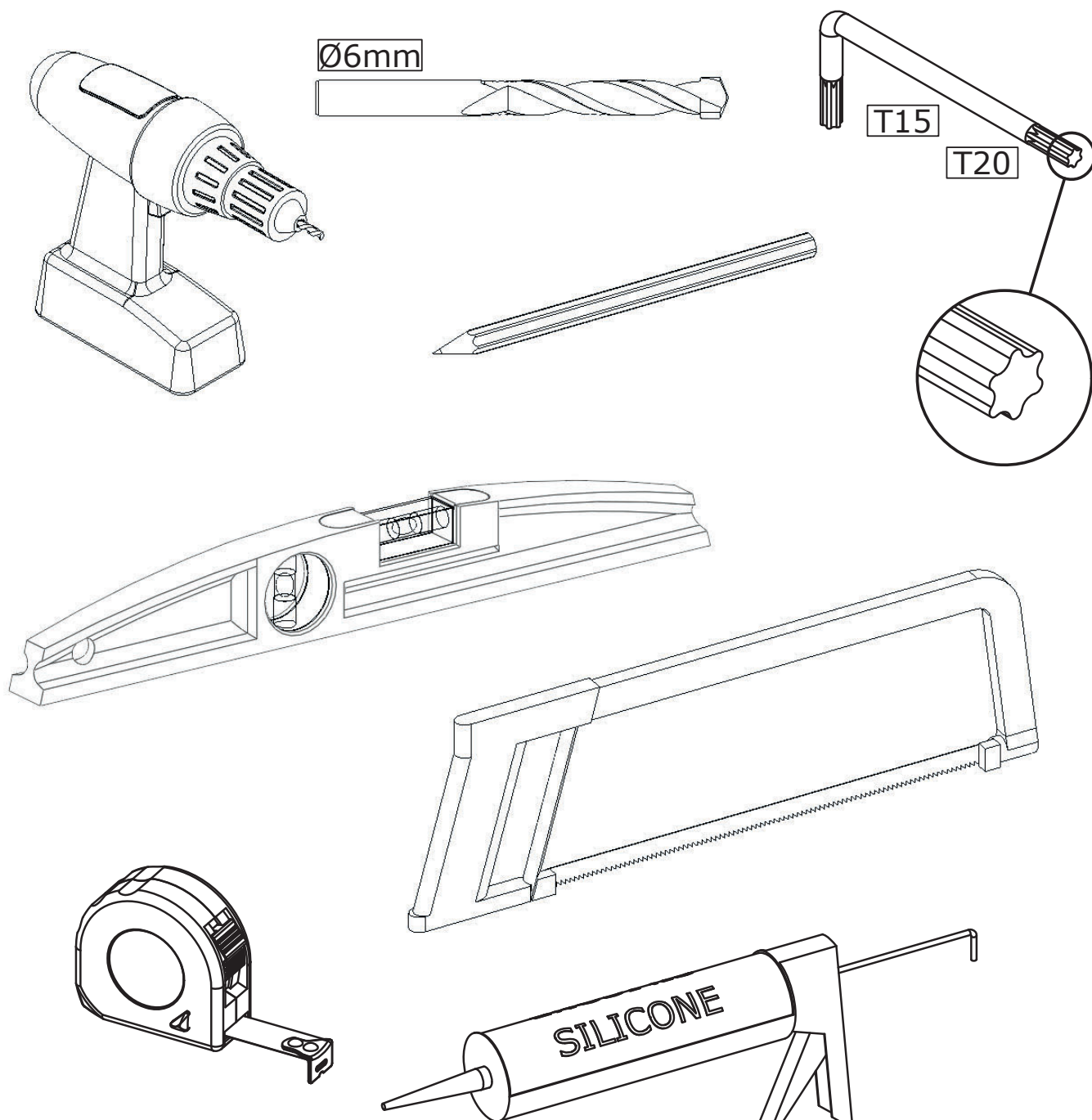

Utiliser un silicone adapté au matériau de chaque support (faïence, acrylique, etc.)  
 Use a silicone sealant that is intended for the surrounding materials (ceramic, acrylic, etc.)  
 Usar una silicona adecuada para cada tipo de material (loza, acrílico, etc.)  
 Utilizar um silicone adequado a cada tipo de material (cerâmica, acrílico, etc.)  
 Utilizzare un silicone adatto a qualsiasi materiale (ceramica, acrilico, ecc.)  
 Gebruik siliconenkit die geschikt is voor iedere ondergrond (tegelwerk, acryl, etc.)  
 Für das jeweilige Trägermaterial (Stein, Acryl usw.) geeignetes Silikon verwenden.

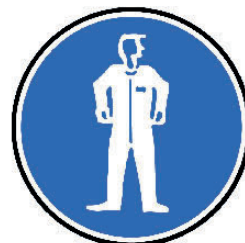

Réversibilité - Reversibility - Reversibilidad - Reversibilidade -  
Reversibilida - Omkeerbaarheid - Wahlweise Montage

Montage à gauche  
Left hand  
Montaje a la izquierda  
Montagem à esquerda  
Montaggio a sinistra  
Montage links  
Montage links

Montage à droite  
Right hand  
Montaje a la derecha  
Montagem à direita  
Montaggio a destra  
Montage rechts  
Montage rechts

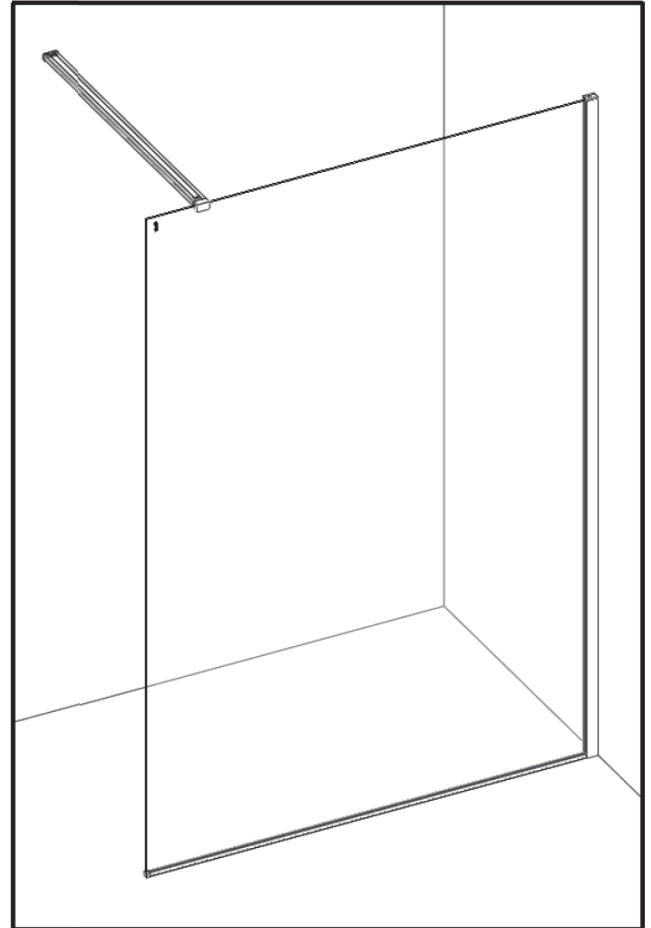
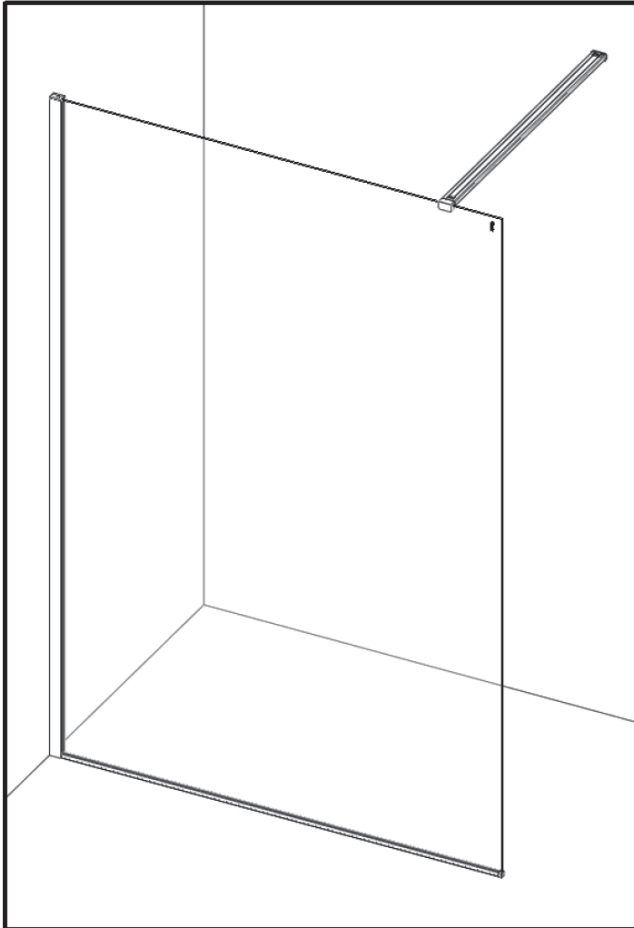

-Vous avez la possibilité de réaliser un montage à droite ou un montage à gauche. Notre notice d'installation décrit un montage à gauche. Si vous voulez réaliser un montage à droite, il vous suffit d'inverser le montage.

-This cubicle can be installed either left or right hand. These installation instructions show a left hand installation.

-Puede realizar un montaje a la derecha o un montaje a la izquierda. Nuestro folleto de instalación describe un montaje a la izquierda. Si desea montar su cabina a la derecha sólo tendrá que realizar el montaje al contrario.

-Pode realizar uma instalação à direita ou uma instalação à esquerda. O nosso manual de instalação descreve uma instalação à esquerda. Se pretende realizar uma instalação à direita, basta inverter a instalação.

-Avete la possibilità di effettuare il montaggio a destra o a sinistra. Il nostro manuale descrive il montaggio a sinistra. Se volete realizzare il montaggio a destra è sufficiente invertire varie fasi di montaggio.

-U kunt de douchecabine rechts of links monteren. Onze handleiding beschrijft de links montage van de cabine. Keer de montage om als u de cabine rechts wilt monteren.

-Sie haben die Möglichkeit, eine Montage auf der linken Seite oder eine Montage auf der rechten Seite durchzuführen. Unsere Montageanleitung beschreibt eine Montage auf der linken Seite. Wenn Sie die Montage lieber auf der rechten Seite durchführen wollen, müssen Sie nur den Montageprozess umkehren.

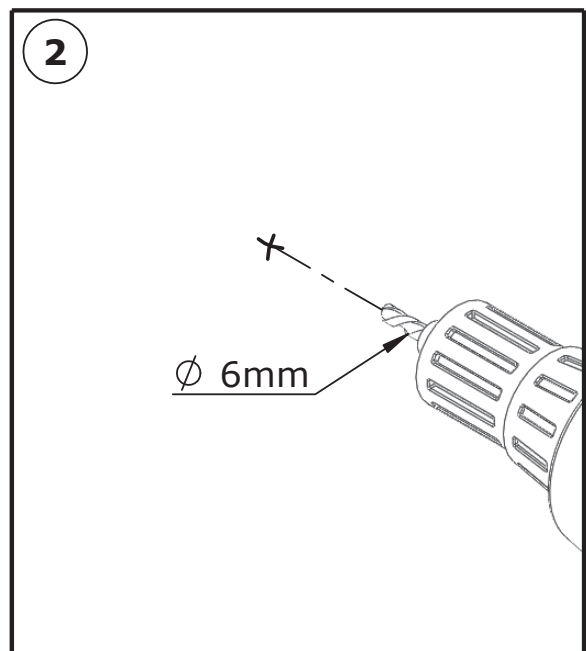
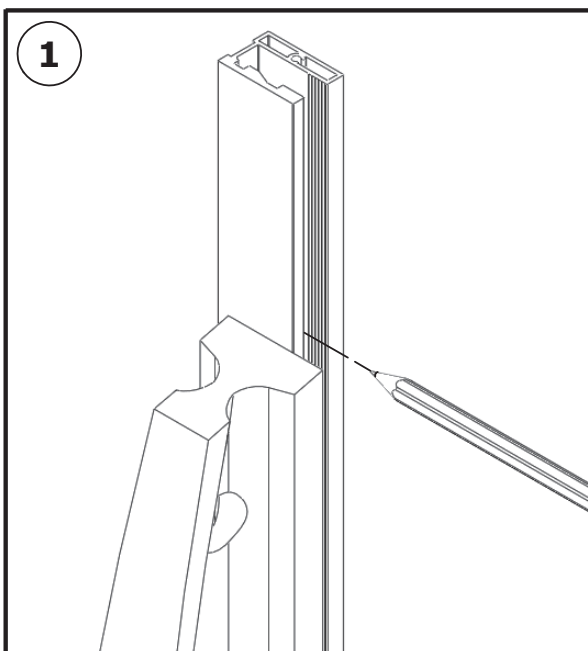
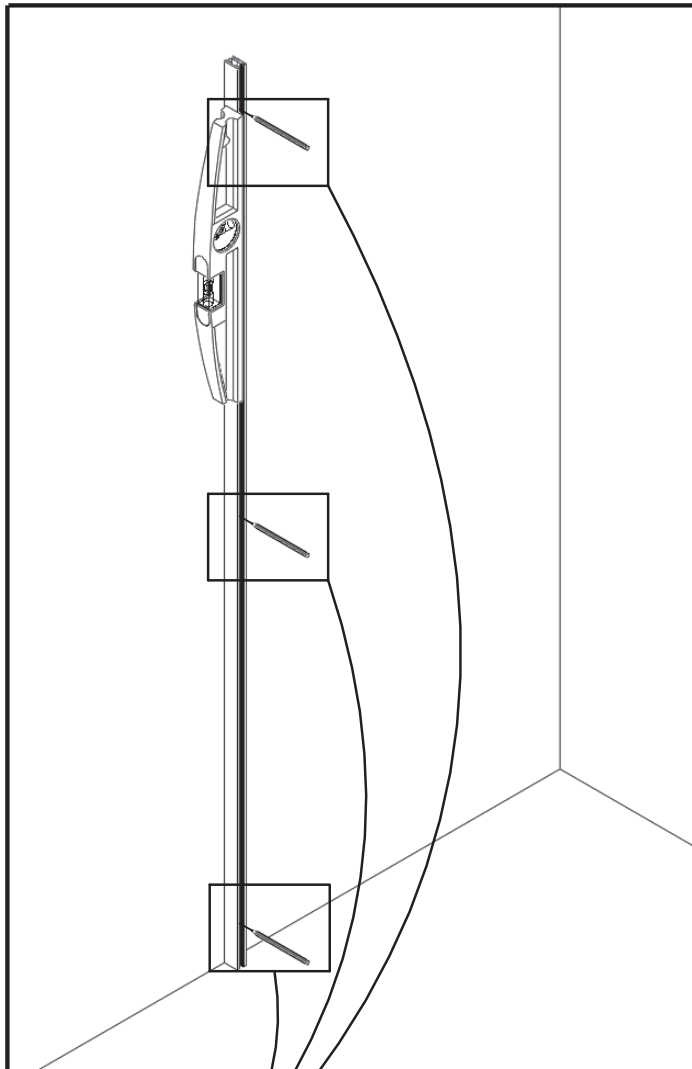
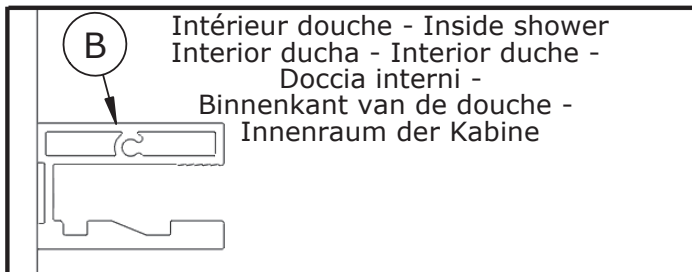

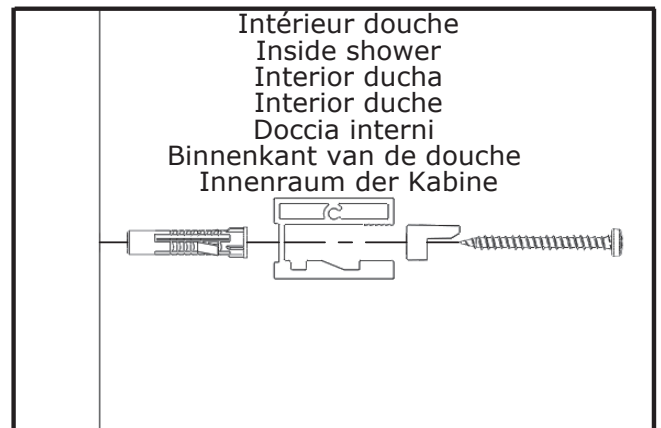
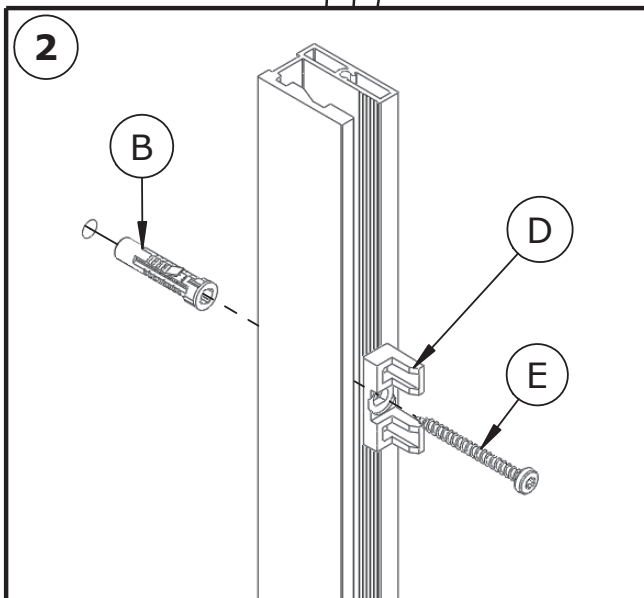
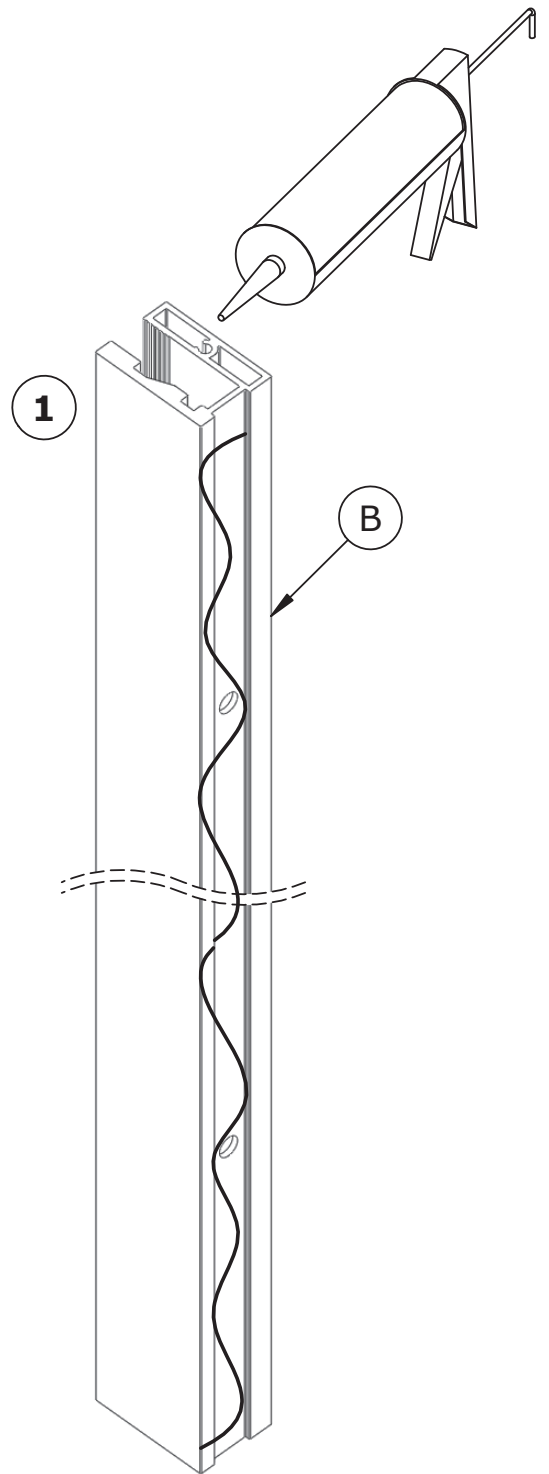
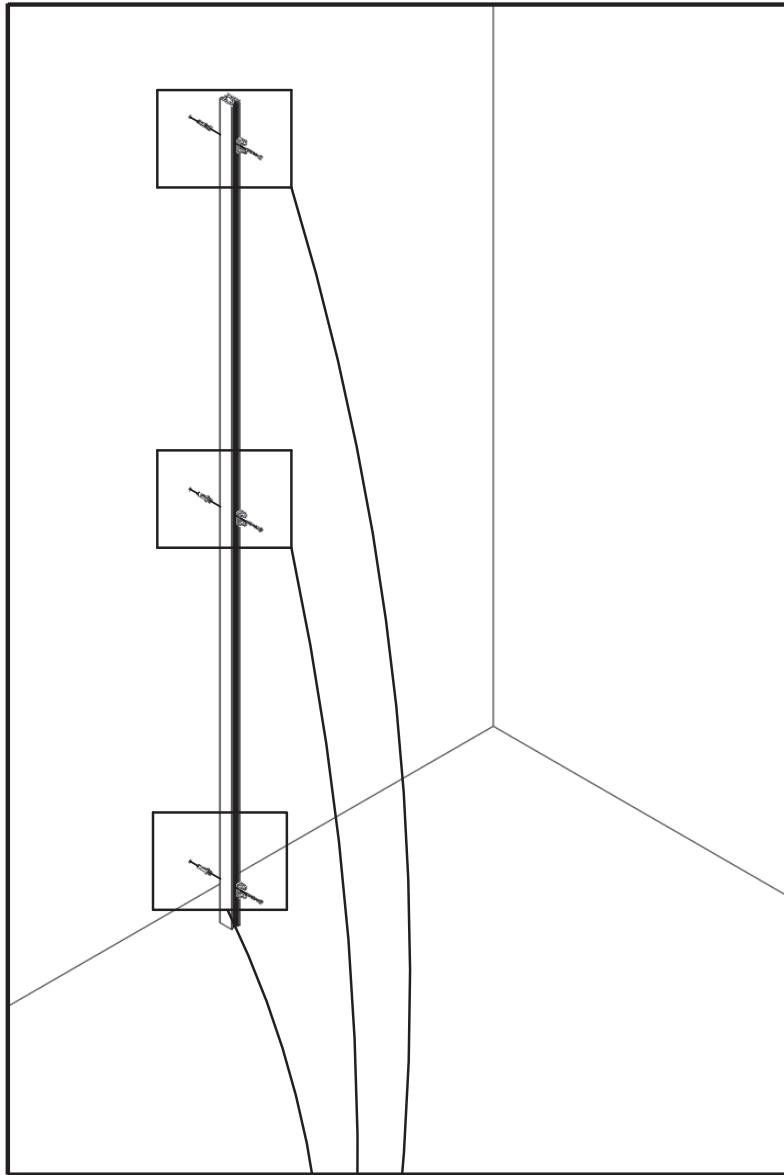

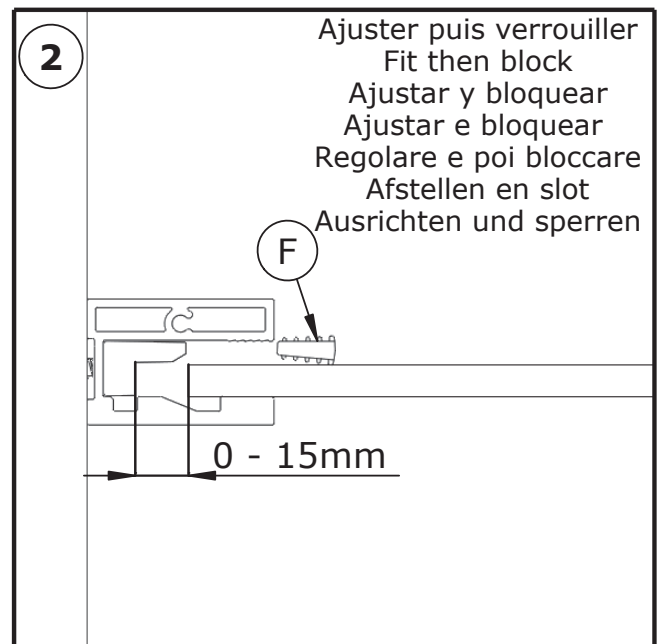
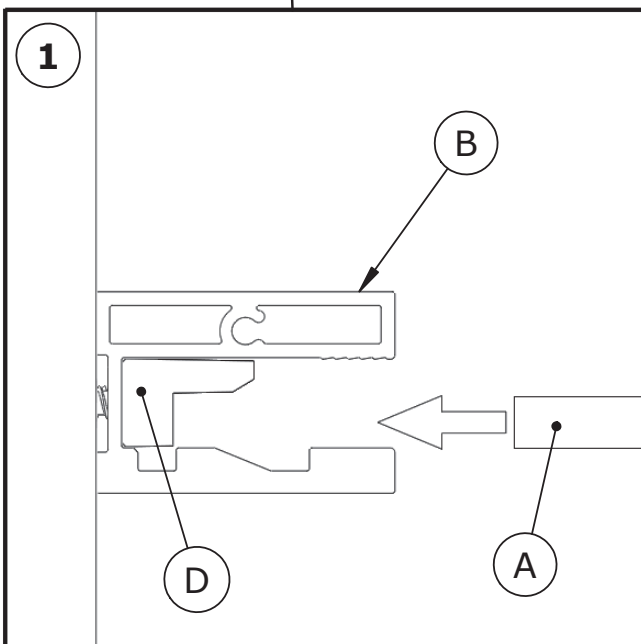
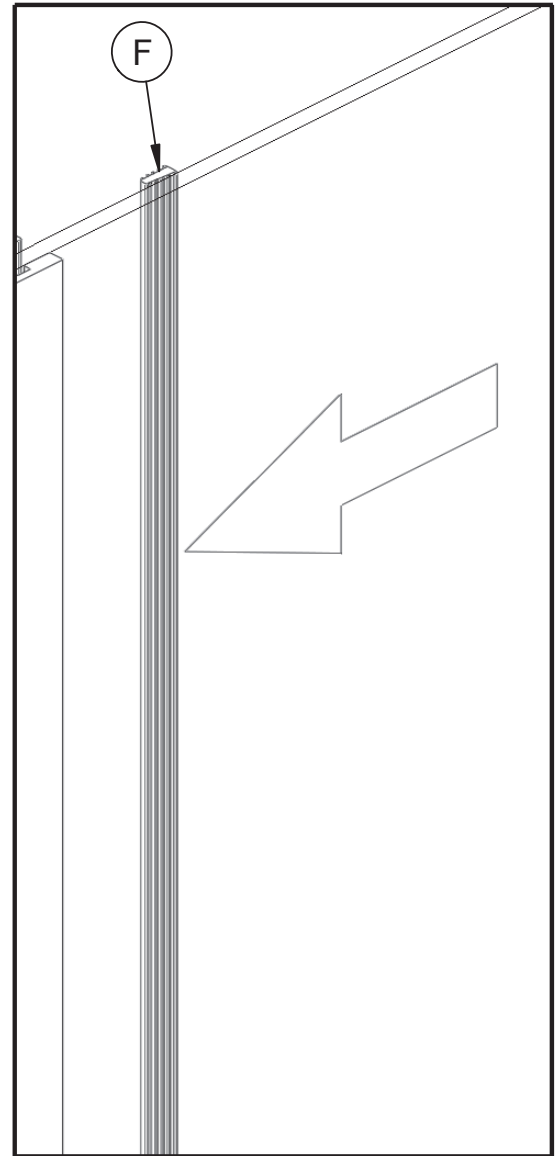
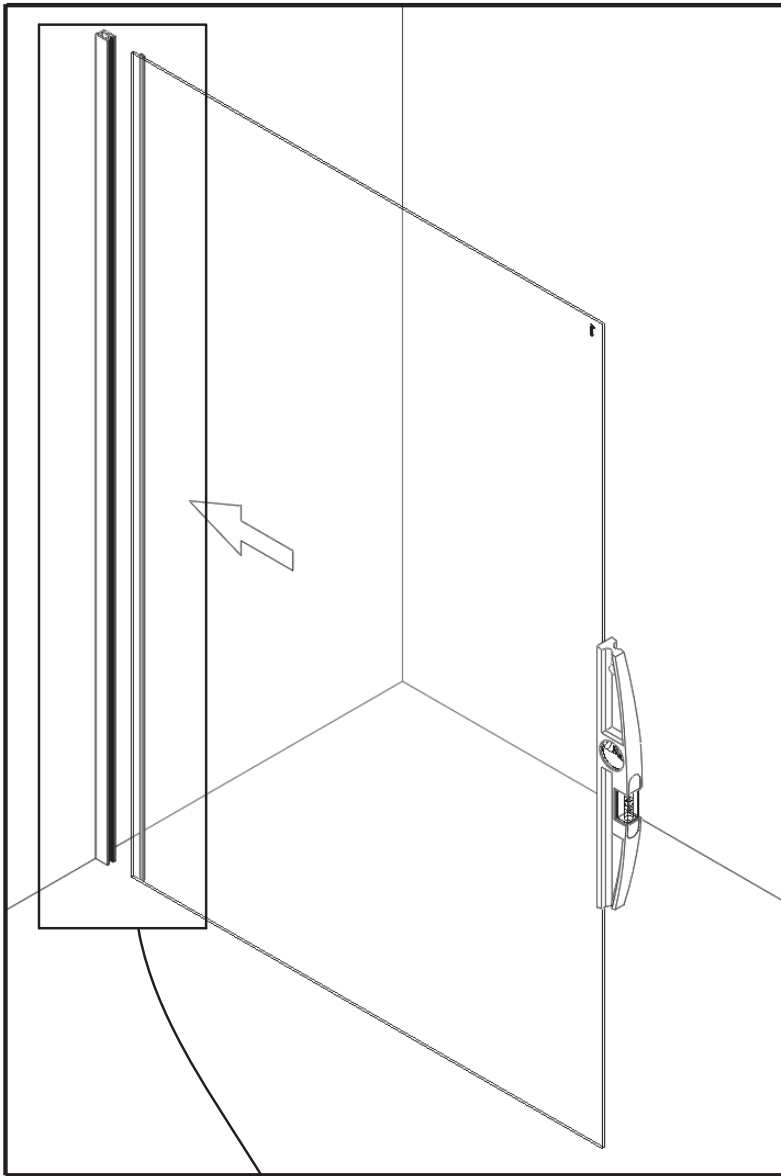



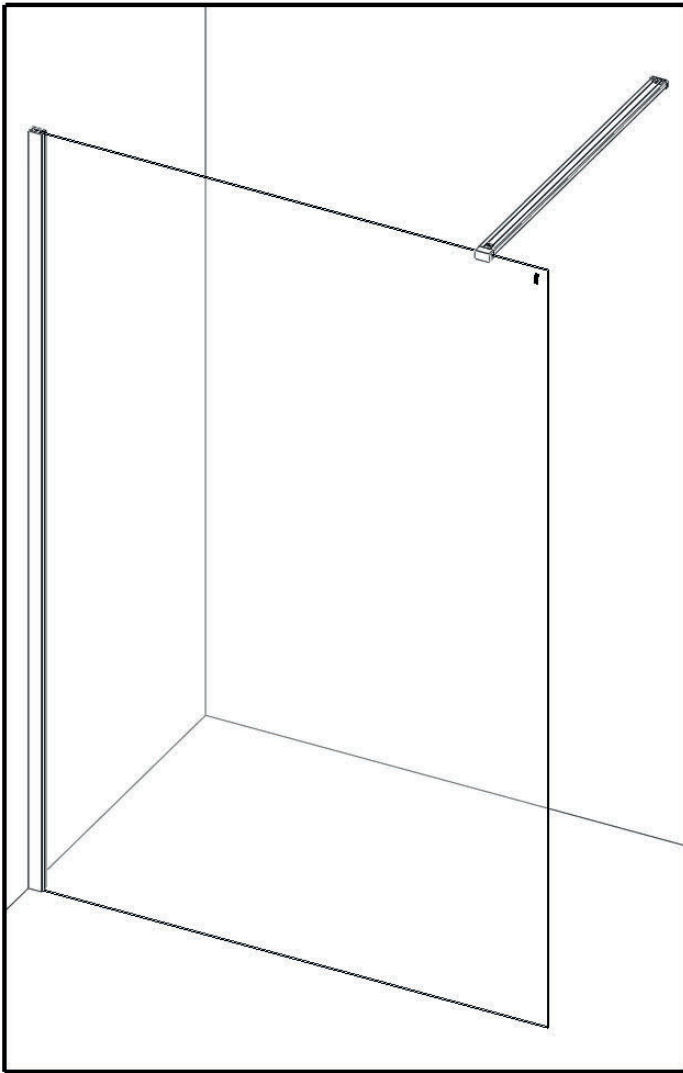

Voir notice concernée  
See installation instructions required  
Ver manual adecuado  
Ver manual adequado  
Vedere manuale appropriato  
Zie de bijbehorende montagehandleiding  
Siehe betreffende Anleitung

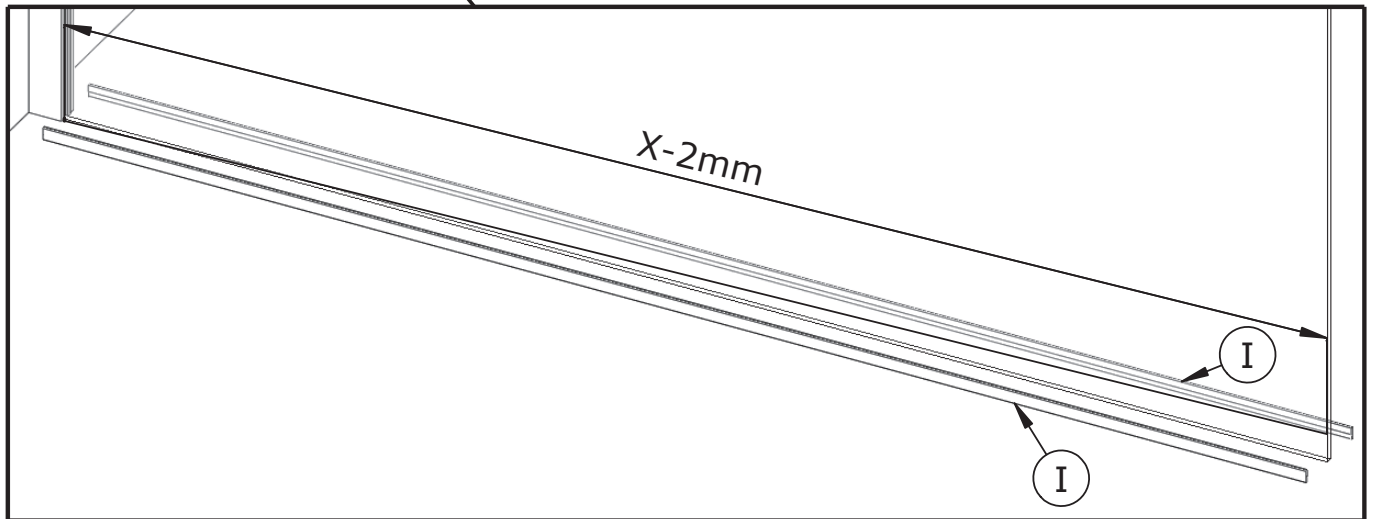
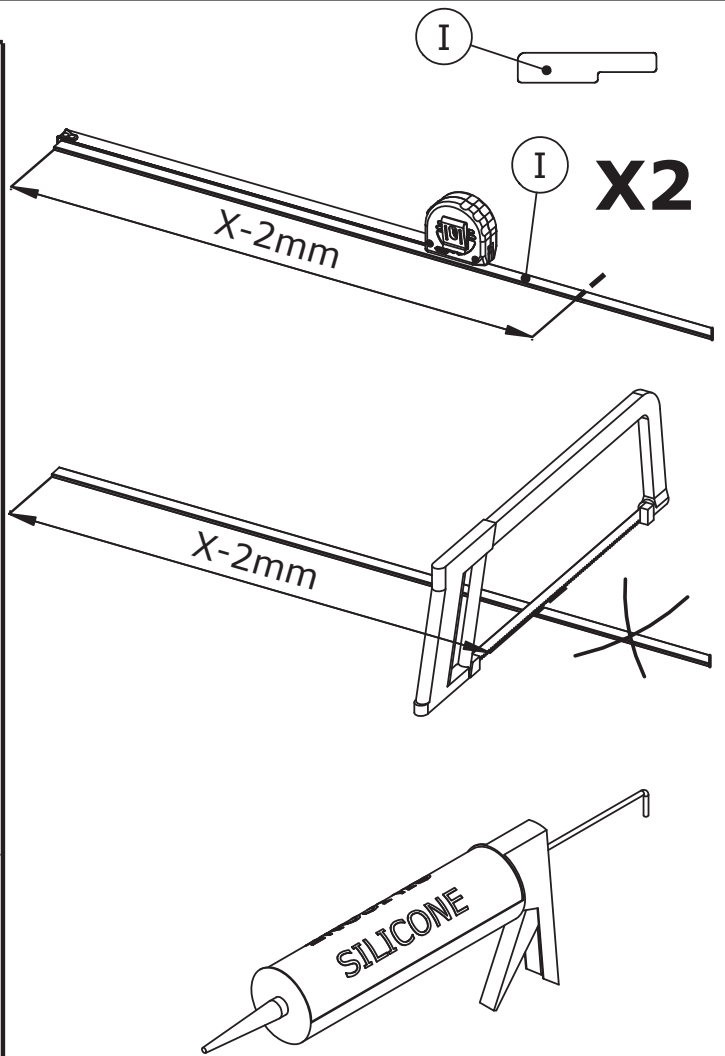
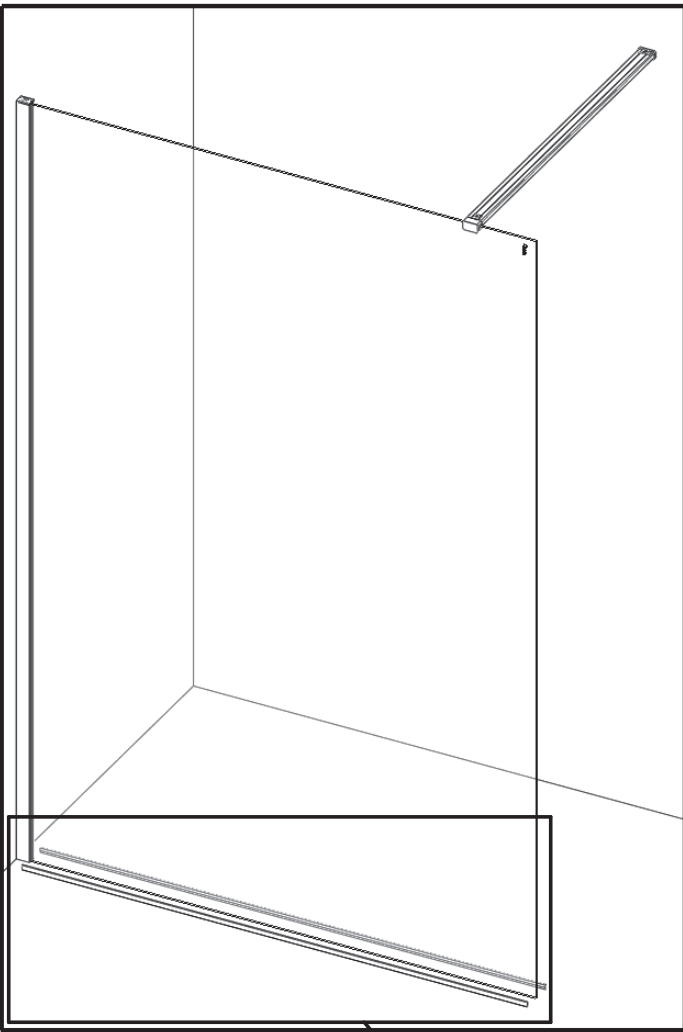



Intérieur - Inside - Interior - Interior - Interno - Binnenkant - Innen	
	-----
Extérieur - Outside - Exterior - Exterior - Esterno - Buitenkant - Außen	

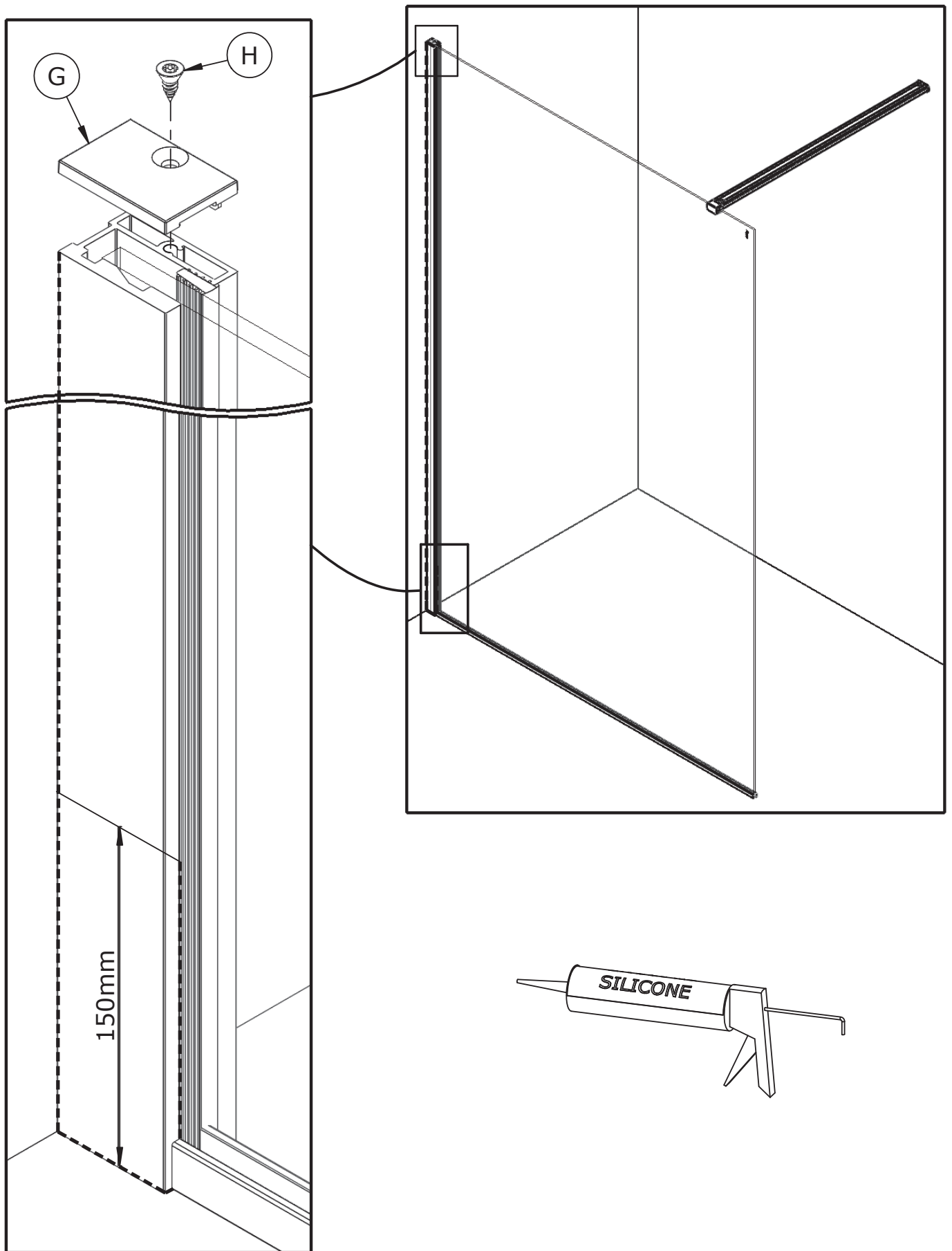



48h

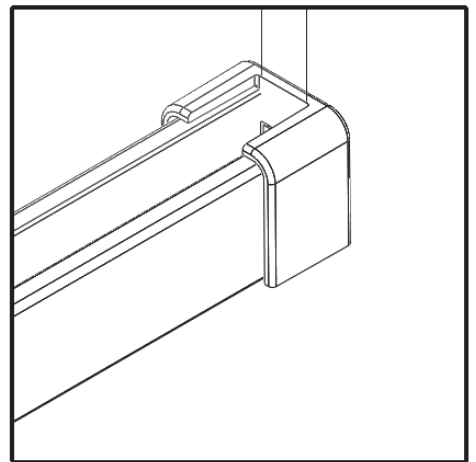
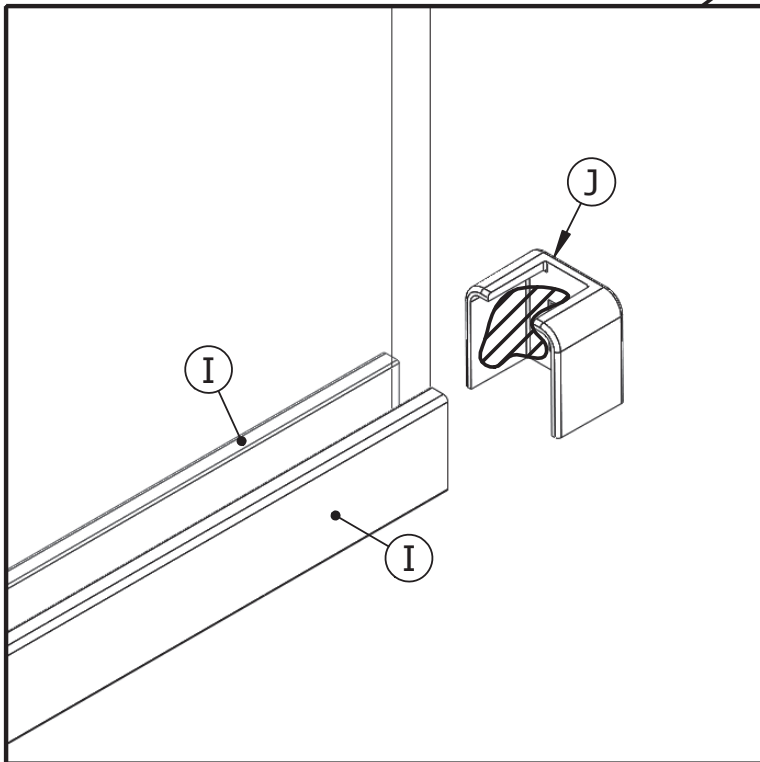
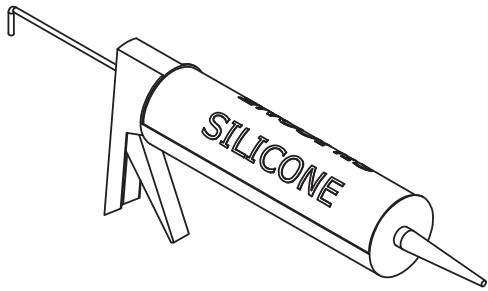
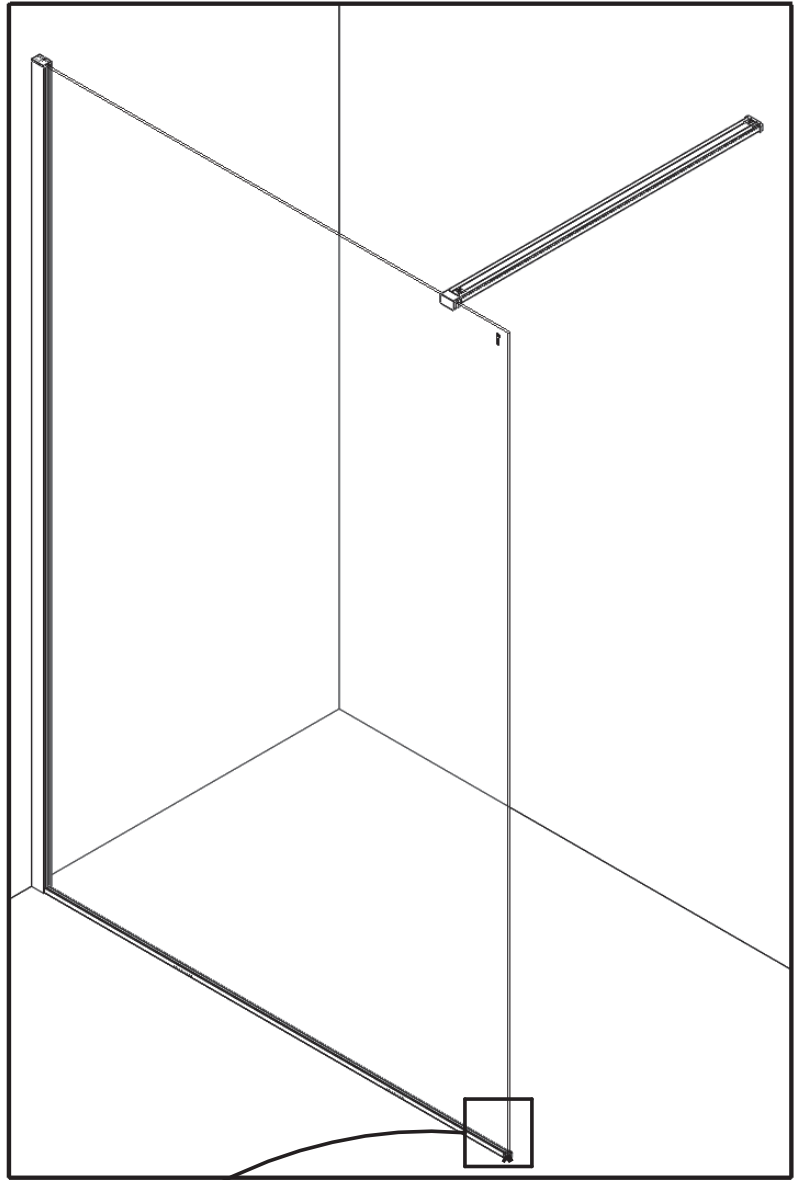

**NOTICE D'ENTRETIEN  
MAINTENANCE INSTRUCTIONS  
ISTRUZIONI DI MANUTENZIONE  
INSTRUCCIONES DE MANTENIMIENTO  
ONDERHOUDSINSTRUCTIE  
WARTUNGSANLEITUNG**

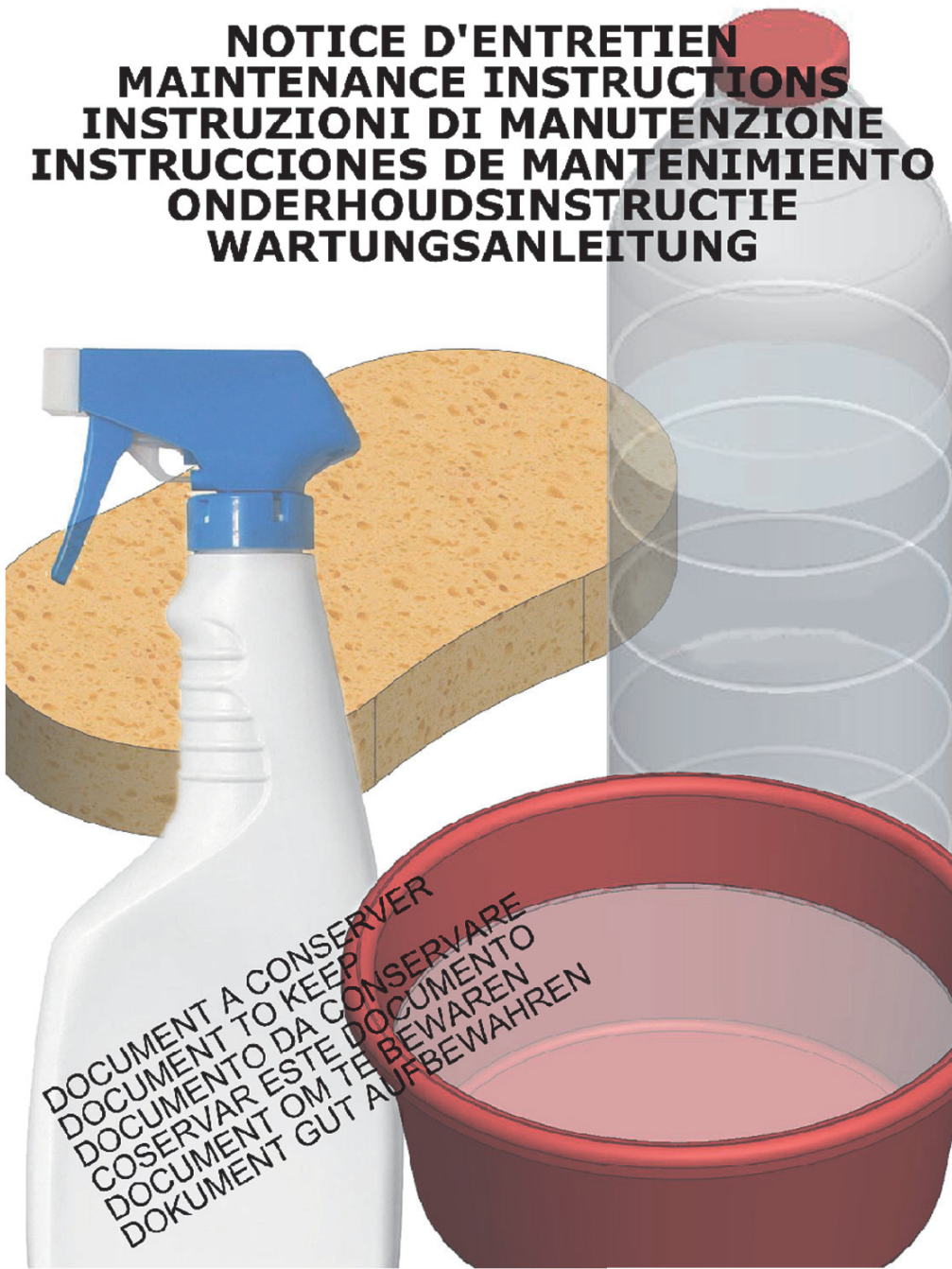

**SCAN ME**







AQUAPRODUCTION, Site industriel,  
F - 44680 Chaumes-en-Retz

20

**EN 14428**

Paroi de douche, fabriquée en verre de silicate  
sodo-calcique de sécurité trempé thermiquement

Aptitude au nettoyage : réussite

Résistance à l'impact/propriétés de fragmentation : réussite

Durabilité : réussite



## SERVICE APRÈS-VENTE AFTER-SALES SERVICE

### FRANCE

+33 (0)2 40 21 29 45

### UK

+44 (0)20 8842 0033

### IRELAND

+353 04697 33102

### DEUTSCHLAND

+49 (0) 6074 / 30928 0

### ITALIA

+39 (0382) 6181

### ÖSTEREICH

+43 1 710 60 70

### SUISSE/SCHWEIZ

+41 (0)32 631 04 74

### ESPAÑA

+34 93 544 60 76

### NEDERLAND

+31 475 487 100

### BELGIQUE/BELGIË

+31 475 487 100

### РОССИЯ

+7 495 258-29-51

### PORTUGAL

+351 219 112 785