

- F Notice de montage ● GB Installation instructions
- E Manual de instalación ● I Istruzioni di montaggio
- NL Montage-instructies ● D Montageanleitung

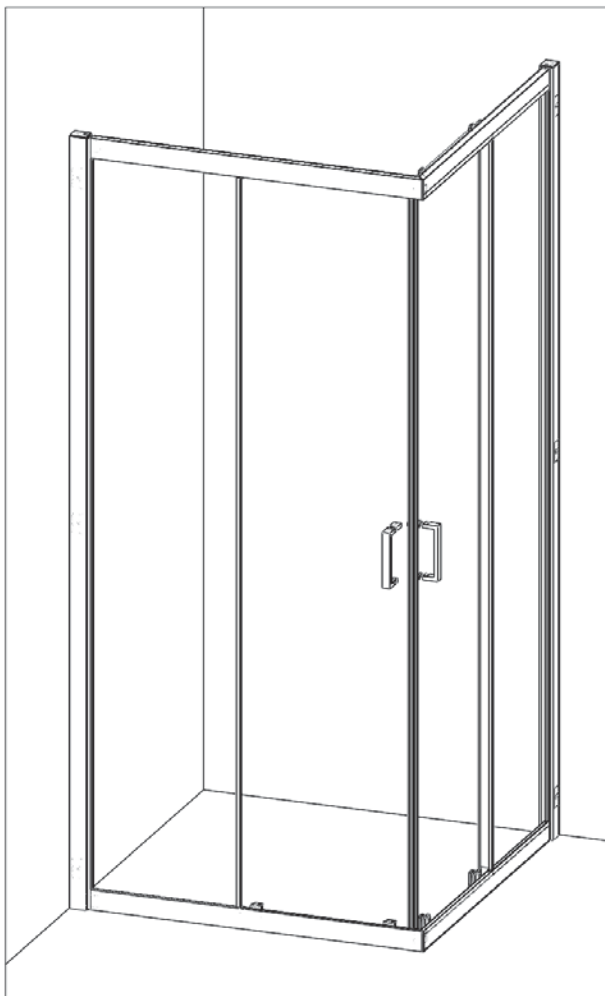

Notre service technique est
à votre écoute aux numéros
qui sont au dos de cette
notice d'installation



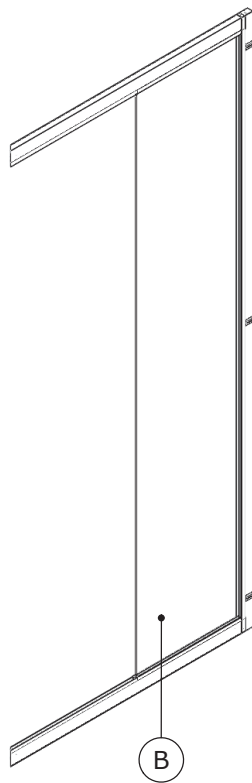
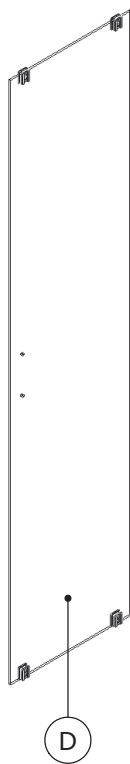
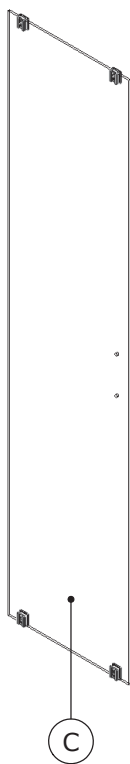
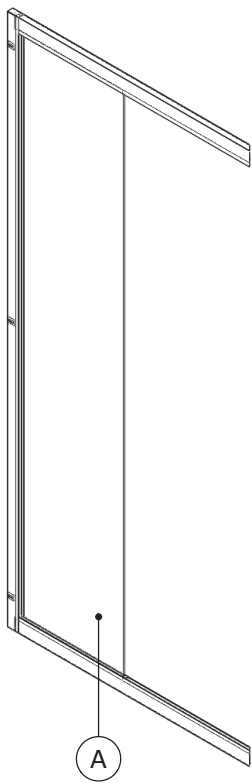

- F Attention aux étapes :
- GB Check installation steps :
- E Atención a los pasos :
- I Attenzione ai passi :
- NL Aandacht voor de stappen :
- D Achtung vor den Schritten :

P. 5 - 15 - 25

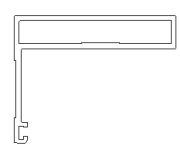
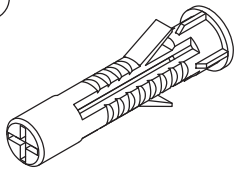
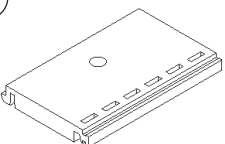

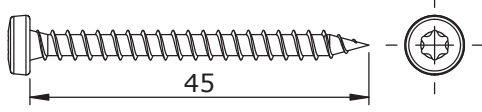
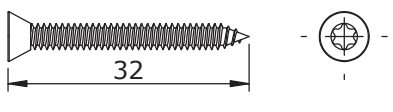



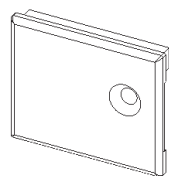
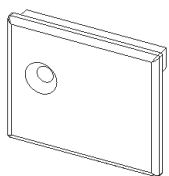

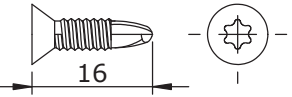
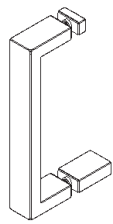
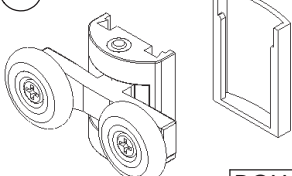
<p>J x2</p>  <p style="text-align: right;">6242</p>	<p>K x6</p>  <p style="text-align: right;">CHE02</p>	<p>L x6</p>  <p style="text-align: right;">PPL1197</p>
--------------------------------------------------------------------------------------------------------------------------------------------------------------------------------------	---------------------------------------------------------------------------------------------------------------------------------------------------------------------------------------	------------------------------------------------------------------------------------------------------------------------------------------------------------------------------------------

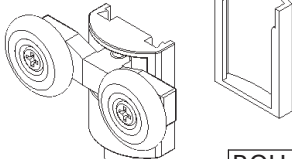
<p>M Ø4 x6</p>  <p style="text-align: center;">45</p> <p style="text-align: right;">1=1 VIS231</p>	<p>N Ø3.5 x6</p>  <p style="text-align: center;">32</p> <p style="text-align: right;">1=1 VIS255</p>
------------------------------------------------------------------------------------------------------------------------------------------------------------------------------------------------------------------------------------------------------------------------------------------------------------------	----------------------------------------------------------------------------------------------------------------------------------------------------------------------------------------------------------------------------------------------------------------------------------------------------------------------

<p>O x2</p>  <p style="text-align: right;">6243</p>	<p>P x1</p>  <p style="text-align: right;">PPL1199</p>	<p>Q x1</p>  <p style="text-align: right;">PPL1120</p>
---------------------------------------------------------------------------------------------------------------------------------------------------------------------------------------	------------------------------------------------------------------------------------------------------------------------------------------------------------------------------------------	------------------------------------------------------------------------------------------------------------------------------------------------------------------------------------------

<p>R Ø3.5 x2</p>  <p style="text-align: center;">16</p> <p style="text-align: right;">1=1 VIS4.2X16</p>	<p>S x2</p>  <p style="text-align: right;">PGN47</p>	<p>T x4</p>  <p style="text-align: right;">ROU46</p>
-----------------------------------------------------------------------------------------------------------------------------------------------------------------------------------------------------------------------------------------------------------------------------------------------------------------------	-----------------------------------------------------------------------------------------------------------------------------------------------------------------------------------------	------------------------------------------------------------------------------------------------------------------------------------------------------------------------------------------

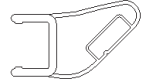
<p>U x4</p>  <p style="text-align: right;">ROU47</p>	<p>V x2</p>  <p style="text-align: right;">Lg=1865mm JOI303</p>	<p>W x2</p>  <p style="text-align: right;">Lg=1800mm JOI303</p>
-----------------------------------------------------------------------------------------------------------------------------------------------------------------------------------------	----------------------------------------------------------------------------------------------------------------------------------------------------------------------------------------------------------------------------------------	----------------------------------------------------------------------------------------------------------------------------------------------------------------------------------------------------------------------------------------

<p>X x2</p>  <p style="text-align: right;">700 Lg=200mm 800 Lg=250mm 900 Lg=300mm JOI303</p>	<p>Y x1</p>  <p style="text-align: right;">AIM36</p>	<p>Z x1</p>  <p style="text-align: right;">AIM37</p>
-----------------------------------------------------------------------------------------------------------------------------------------------------------------------------------------------------------------------------------------------------------------------------	------------------------------------------------------------------------------------------------------------------------------------------------------------------------------------------	------------------------------------------------------------------------------------------------------------------------------------------------------------------------------------------

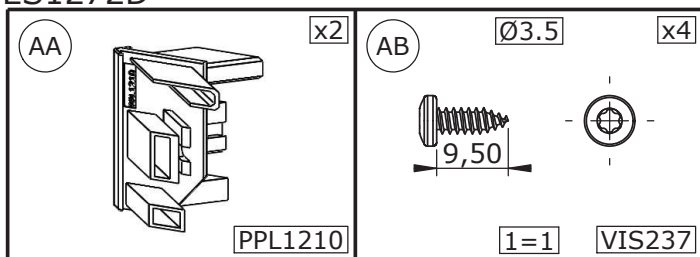

- Les quantités données sont les quantités utiles au montage. les sachets fournis contiennent des pièces supplémentaires.
- The quantities given are what are required for the installation. There may be some surplus in the package provide.
- Las cantidades indicadas son las cantidades necesarias para el montaje. Las bolsitas incluidas contienen piezas suplementarias.
- Le quantità fornite sono le quantità necessarie al montaggio. I sacchetti forniti contengono pezzi supplementari.
- De aangegeven aantallen zijn vereist voor de montage. De verpakking bevat extra onderdelen.
- Die Mengenangaben beziehen sich auf die für die Montage nötigen Teile. Eventuell weitere beige packte Teile ignorieren.

• Outillage nécessaire • Tools required • Equipamiento necesario
 • Attrezzatura necessaria • Benodigde gereedschap • Werkzeuge erforderlich

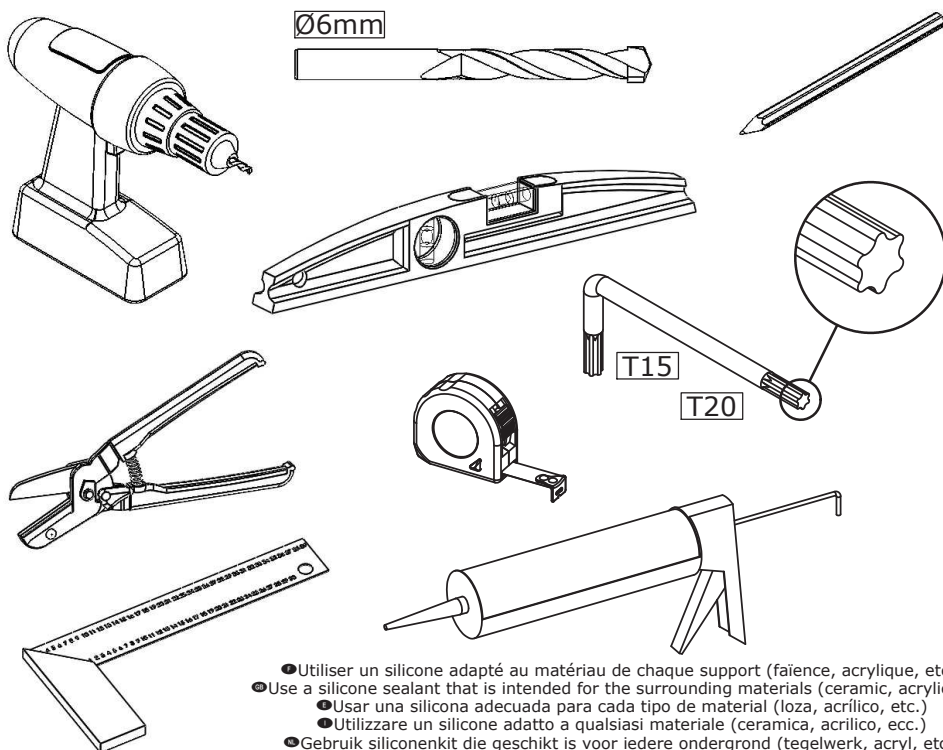

- Utiliser un silicone adapté au matériau de chaque support (faïence, acrylique, etc.)
- Use a silicone sealant that is intended for the surrounding materials (ceramic, acrylic, etc.)
- Usar una silicona adecuada para cada tipo de material (loza, acrílico, etc.)
- Utilizzare un silicone adatto a qualsiasi materiale (ceramica, acrilico, ecc.)
- Gebruik siliconenkit die geschikt is voor iedere ondergrond (tegelwerk, acryl, etc.)
- Für das jeweilige Trägermaterial (Stein, Acryl usw.) geeignetes Silikon verwenden.



INFO:

- Montage possible depuis l'intérieur de la douche
- Can be mounted from inside the shower
- Puede montarse desde el interior de la ducha
- Può essere montato dall'interno della doccia
- Kan worden gemonteerd vanuit de douche
- Kann aus dem Inneren der Dusche montiert werden

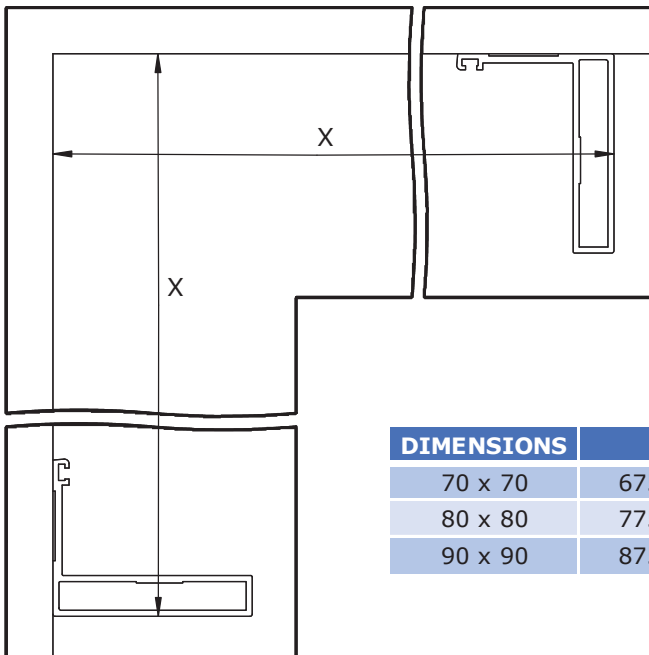
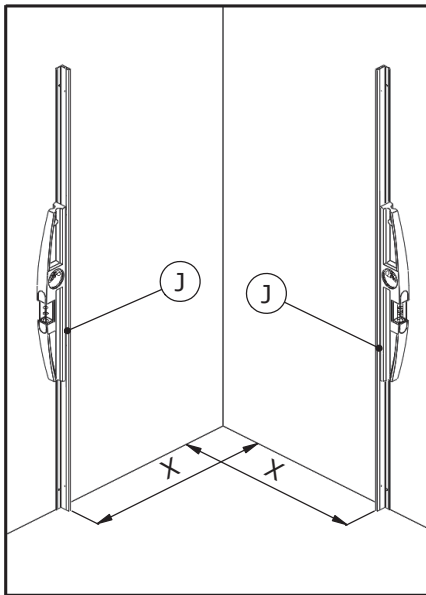

DIMENSIONS	X
70 x 70	675 - 690
80 x 80	775 - 790
90 x 90	875 - 890

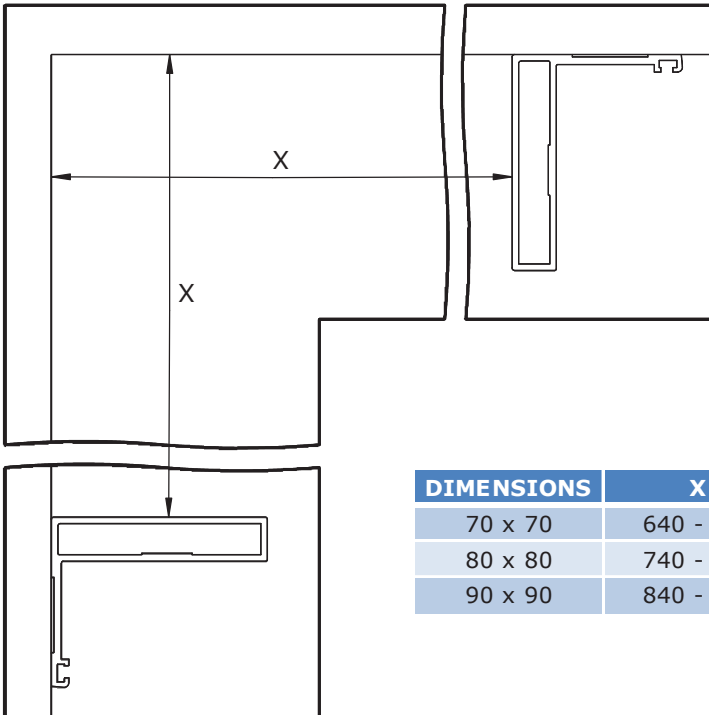
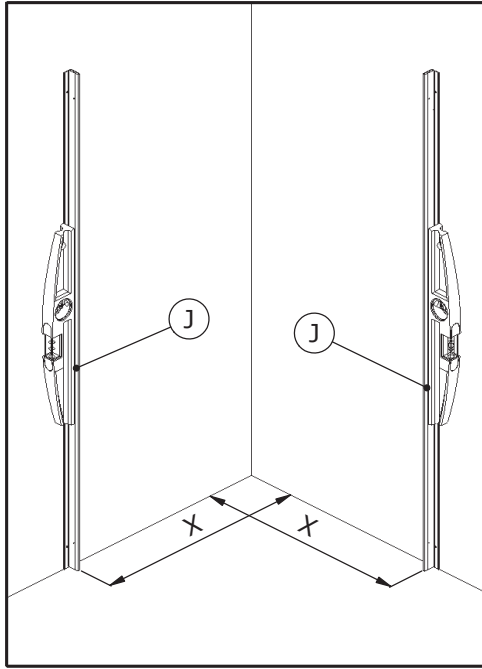

DIMENSIONS	X
70 x 70	640 - 655
80 x 80	740 - 755
90 x 90	840 - 855

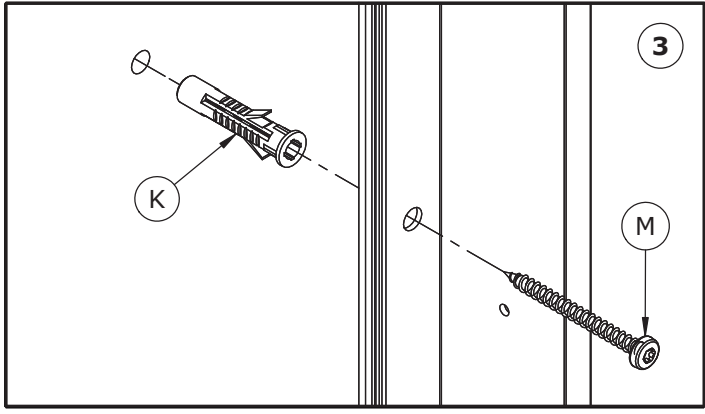
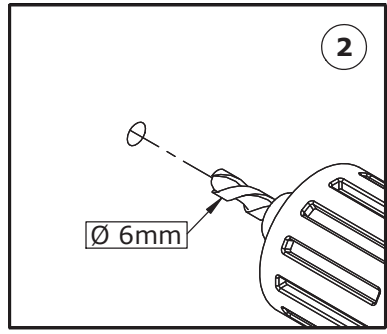
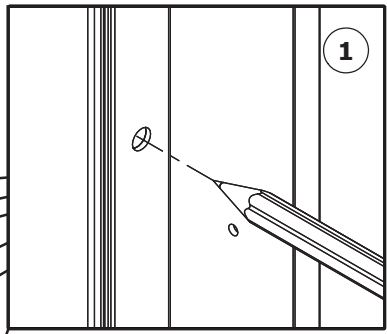
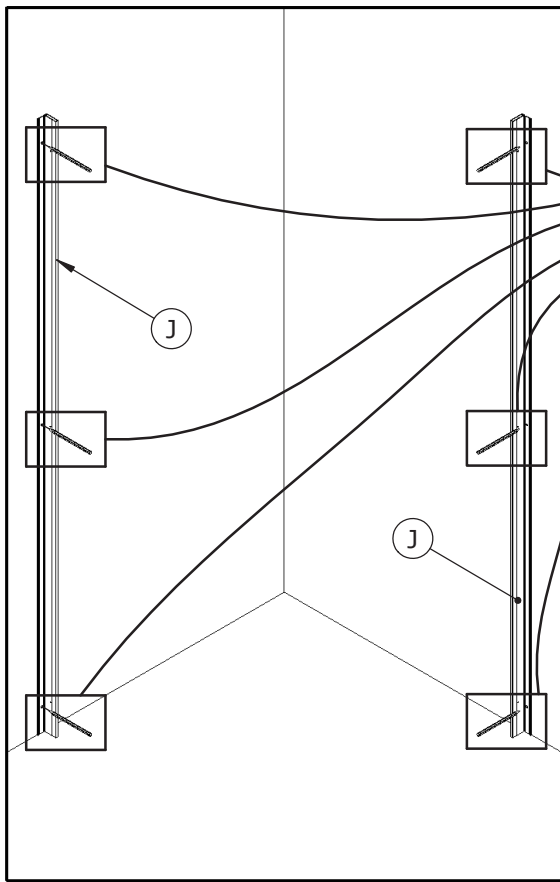

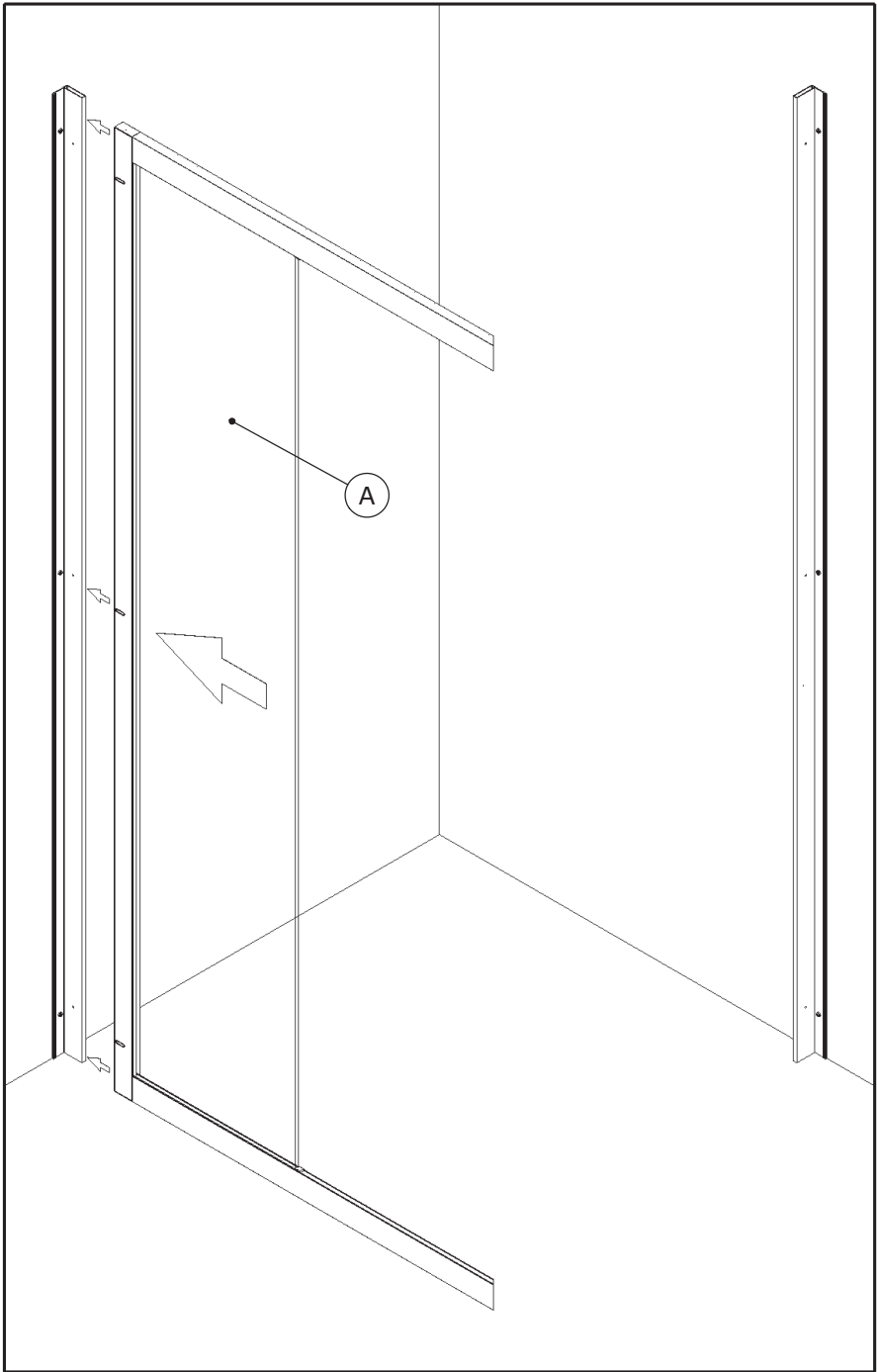

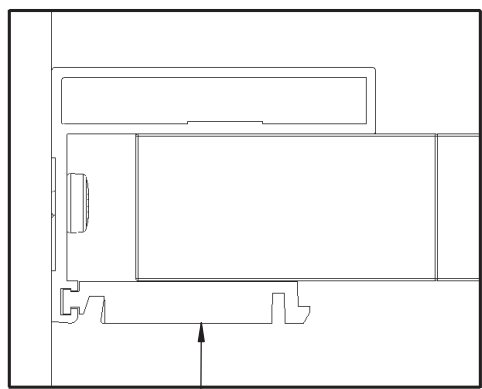
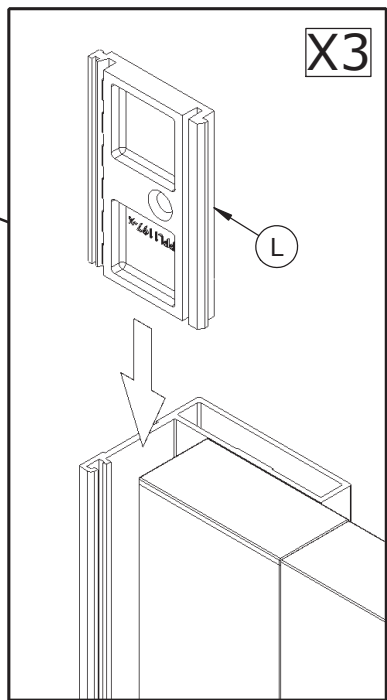
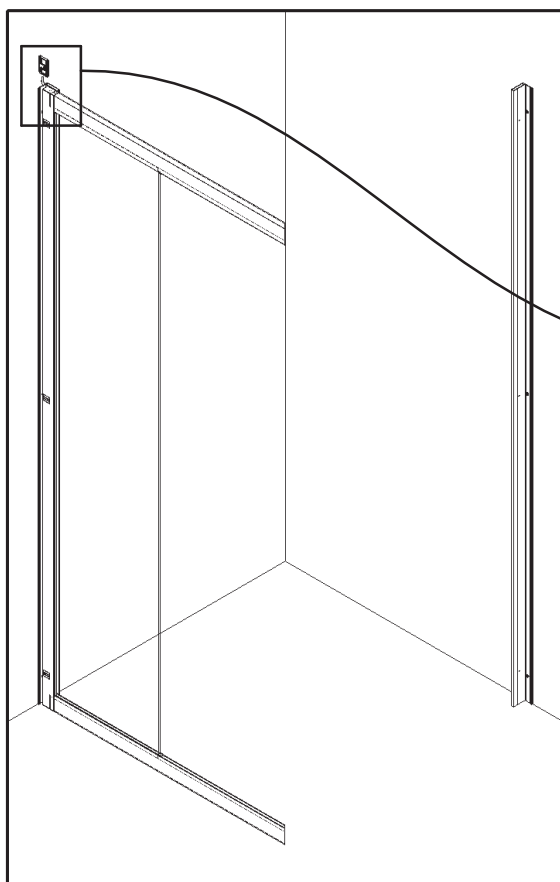

L

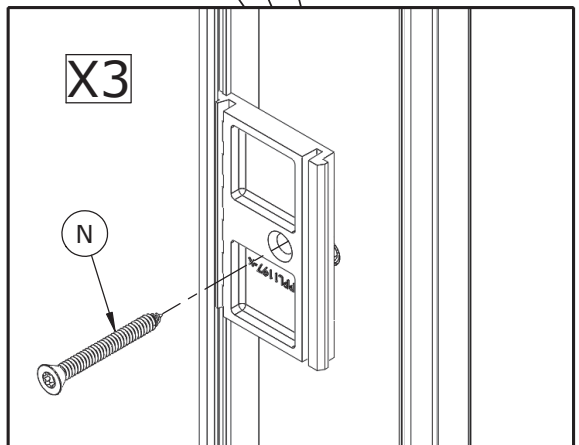
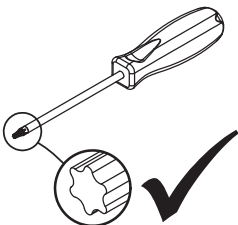
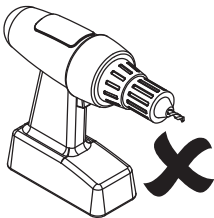
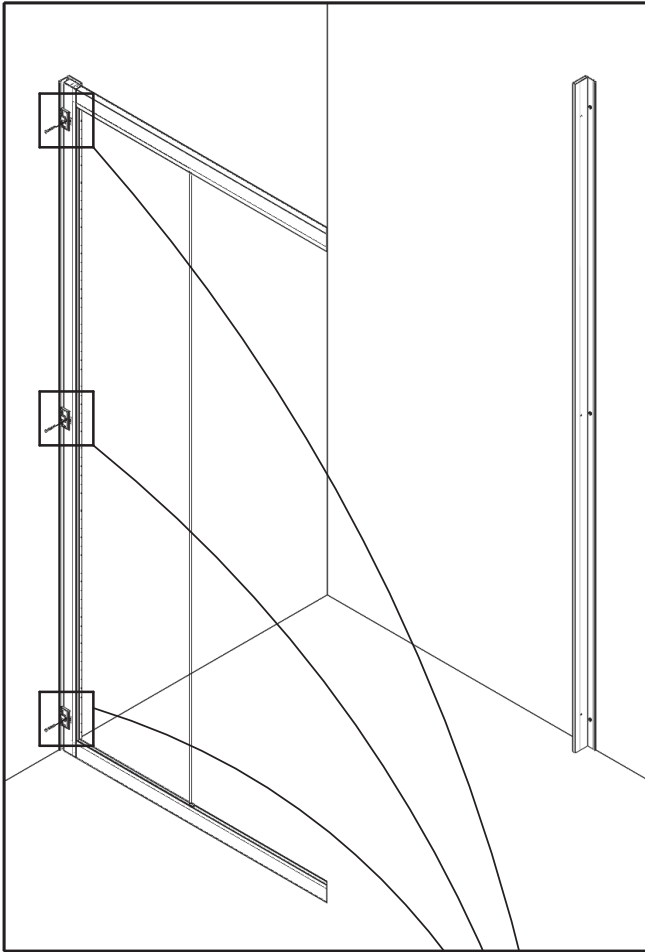

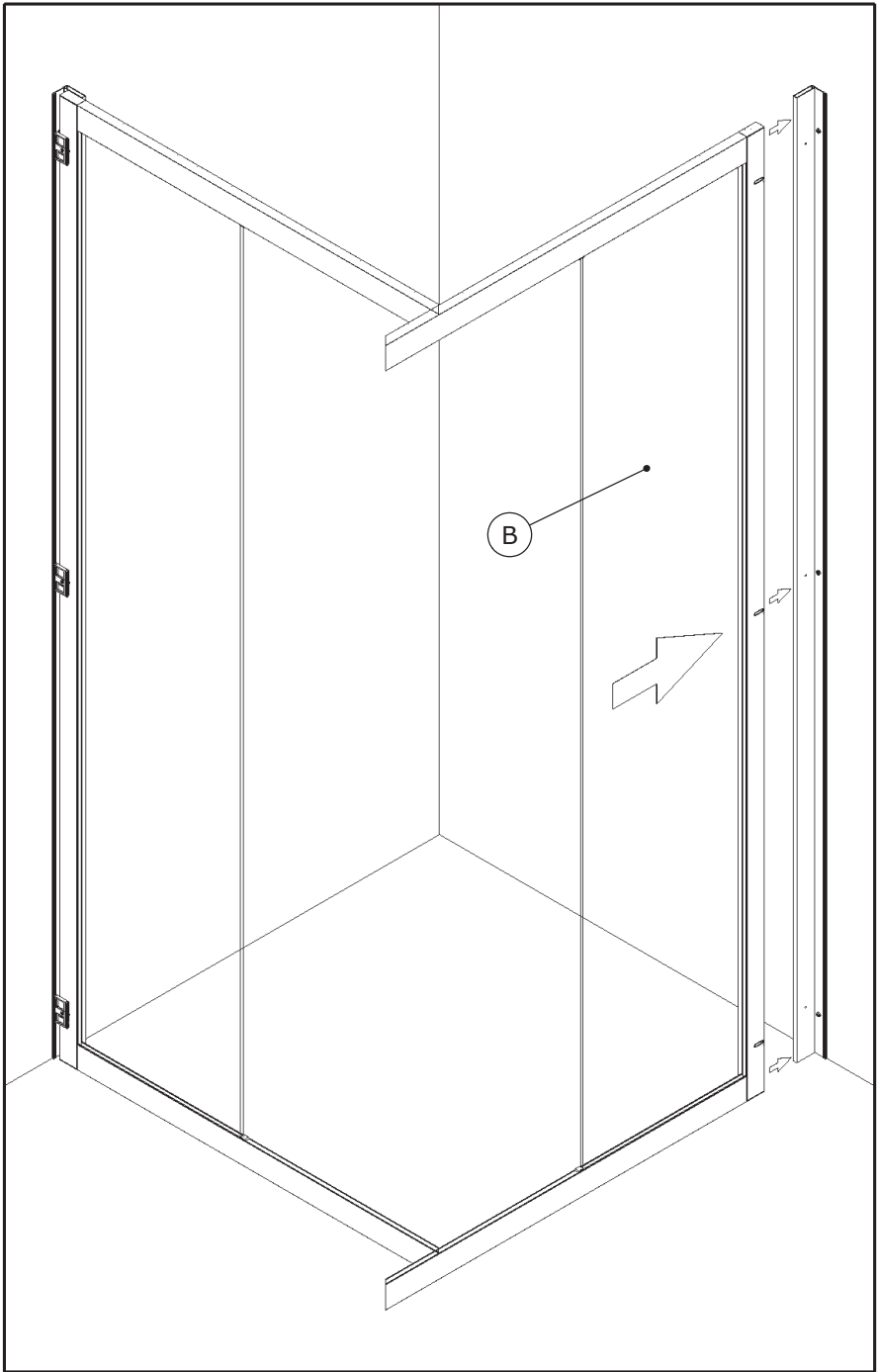

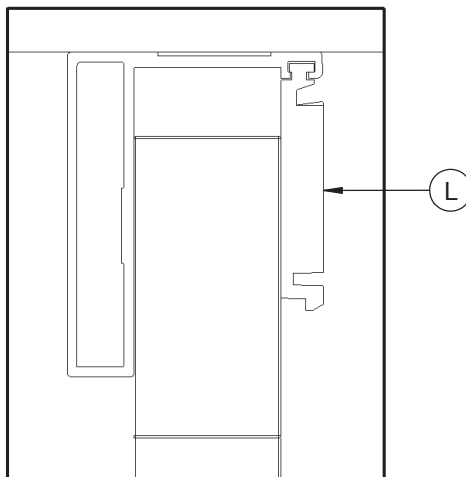
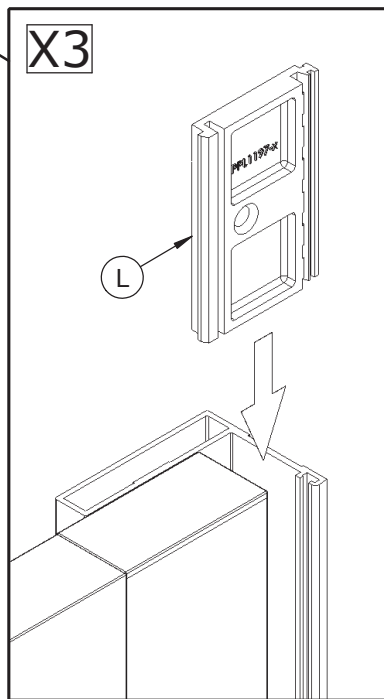
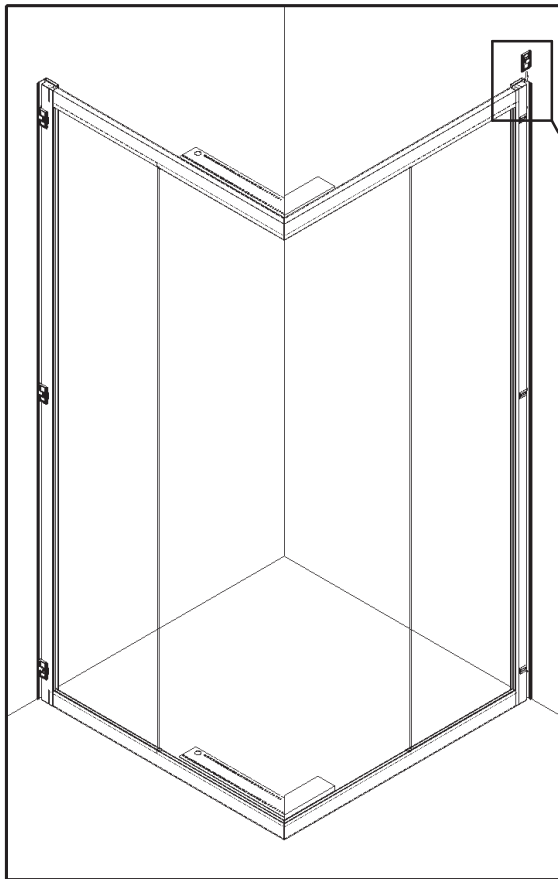

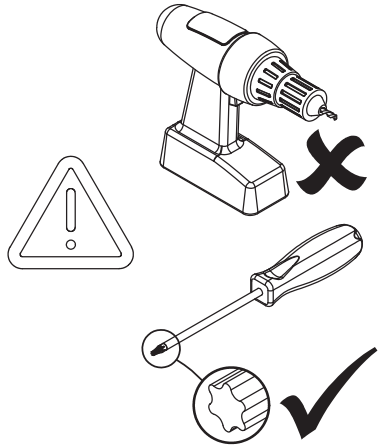
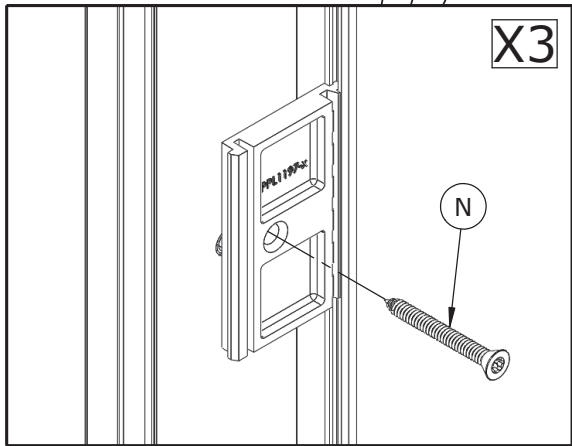
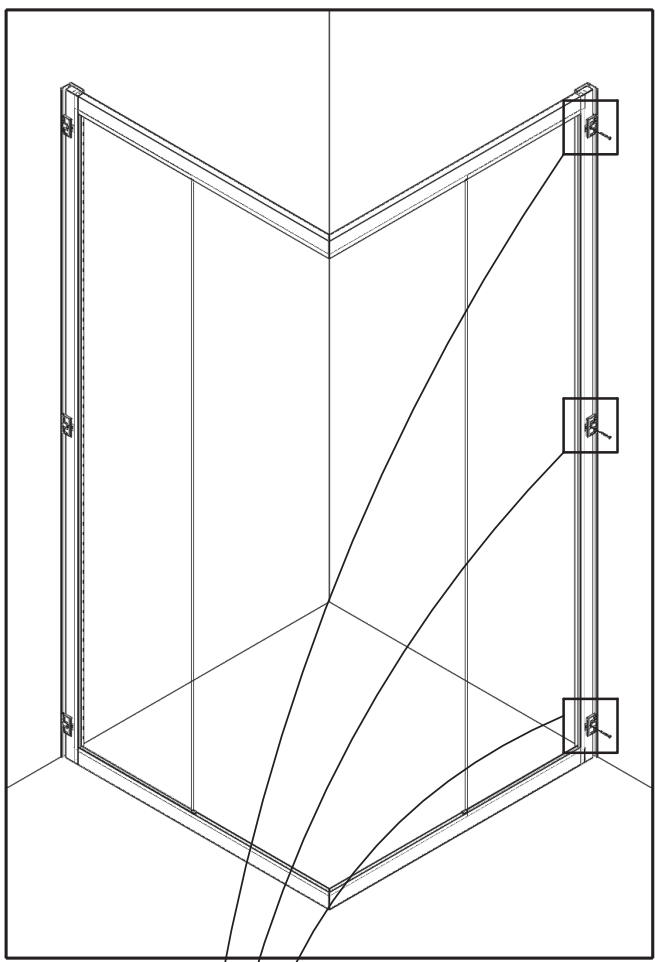

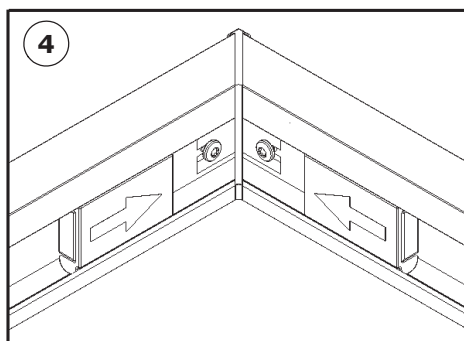
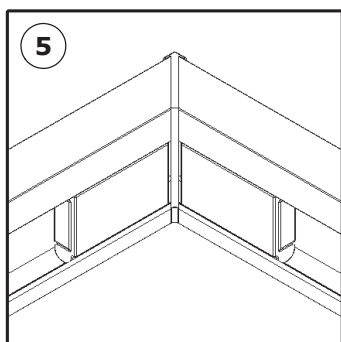
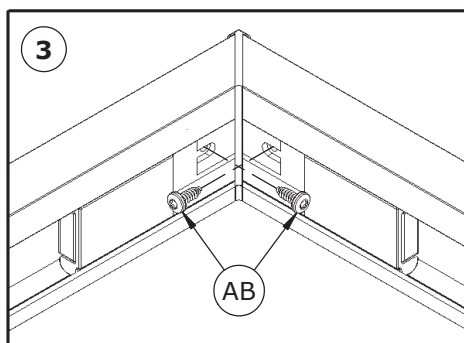
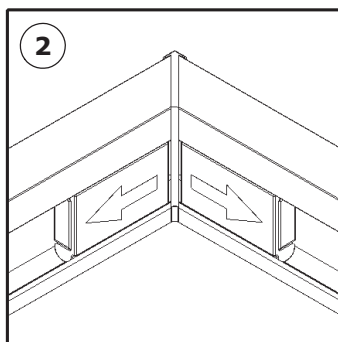
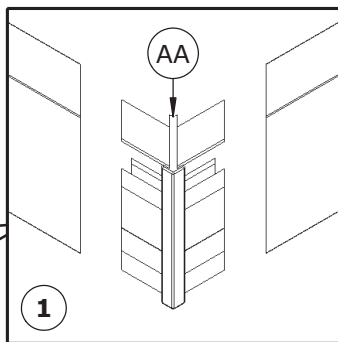
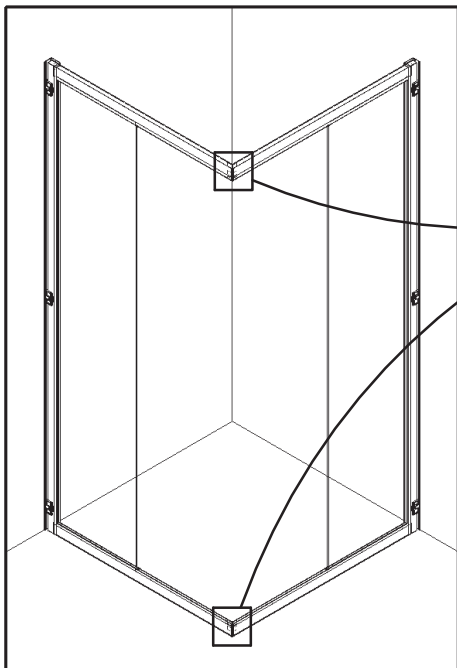

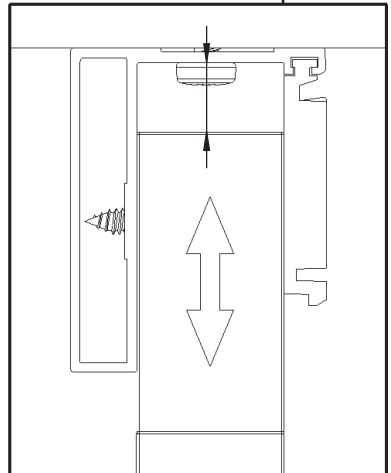
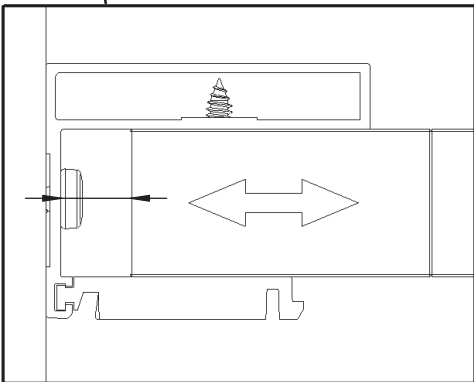
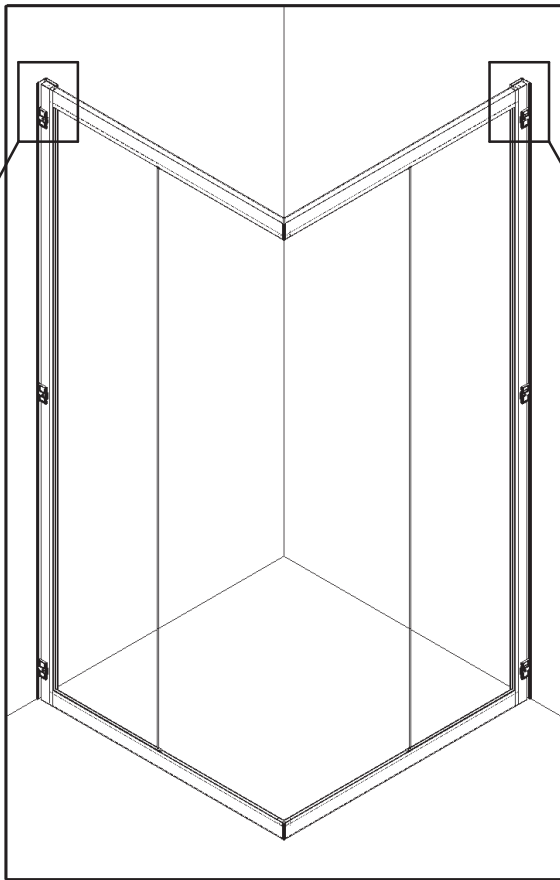

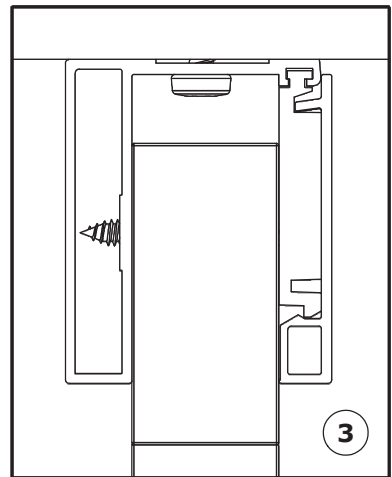
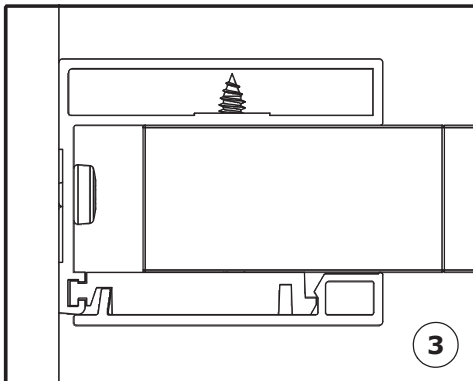
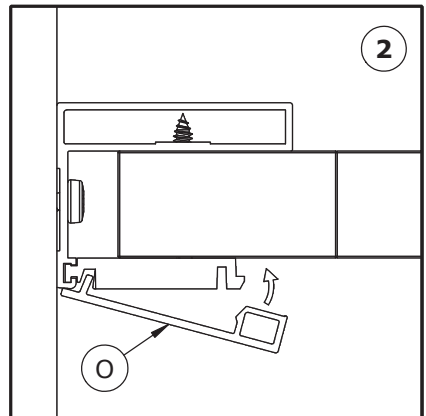
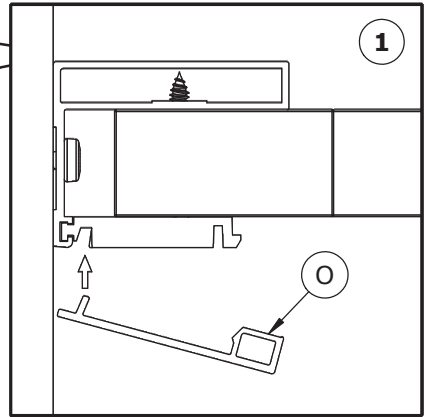
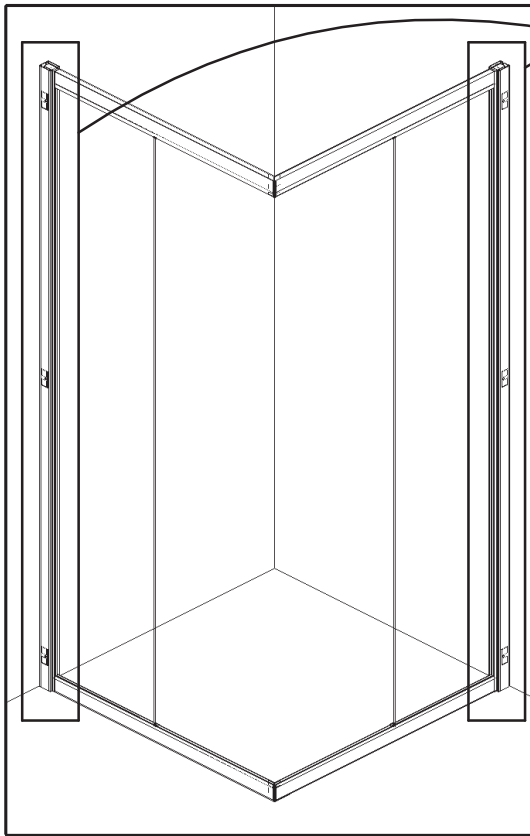

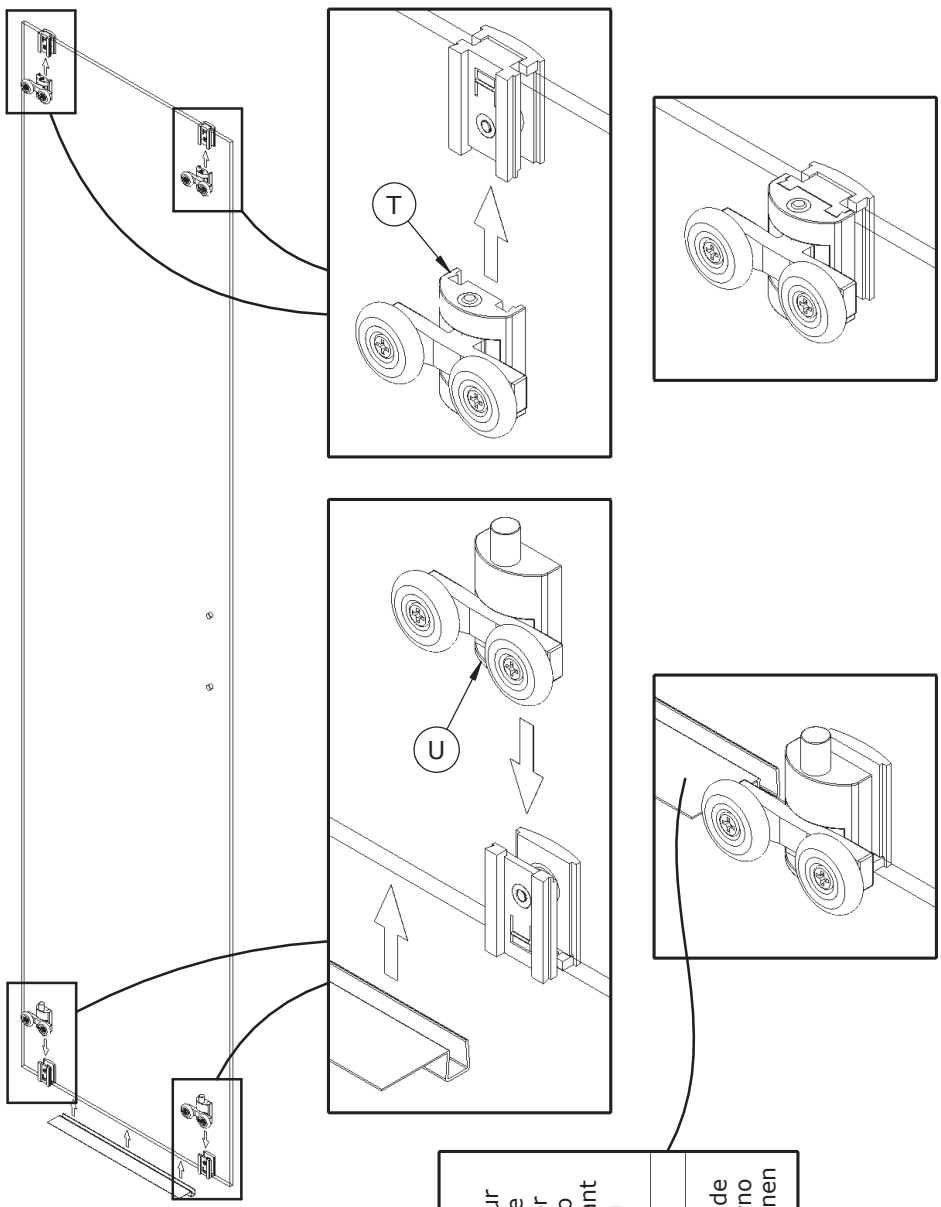

● Extérieur
 ● Outside
 ● Exterior
 ● Externo
 ● Buitenkant
 ● Außen

● Intérieur
 ● Inside
 ● Interior
 ● Interno
 ● Binnenkant
 ● Innen

X →

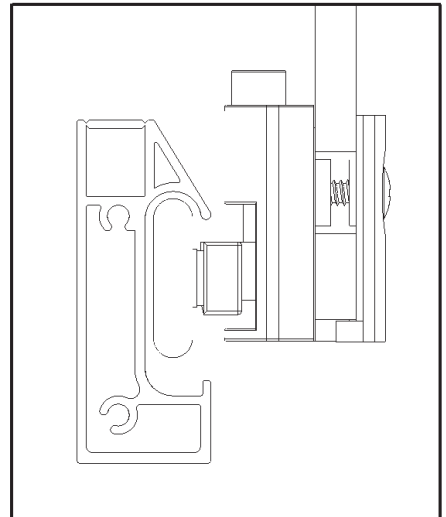
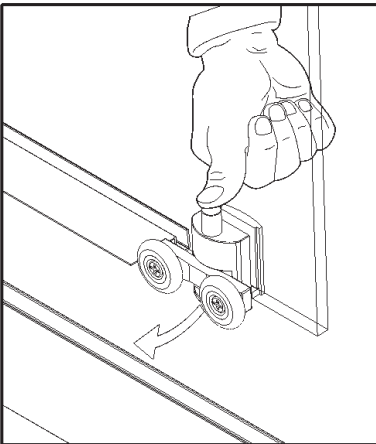
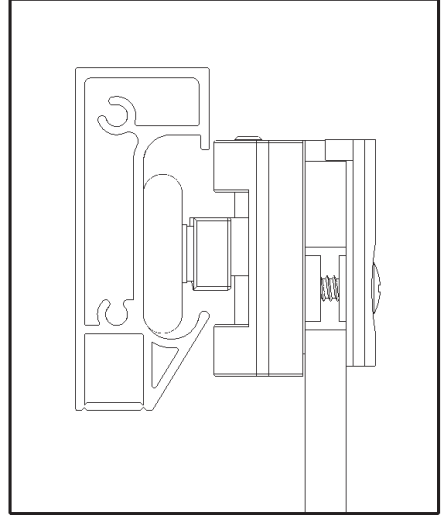
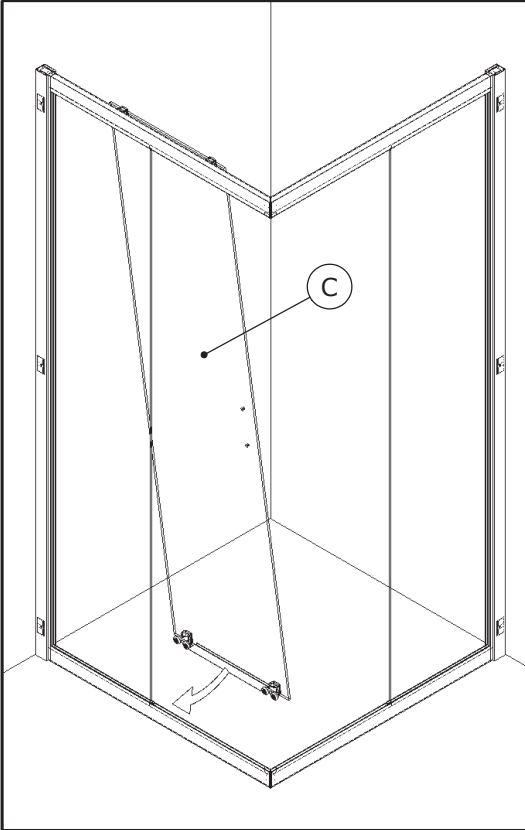

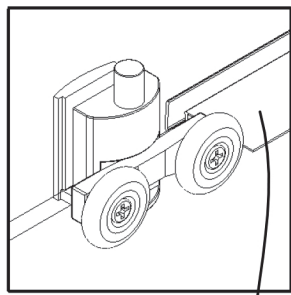
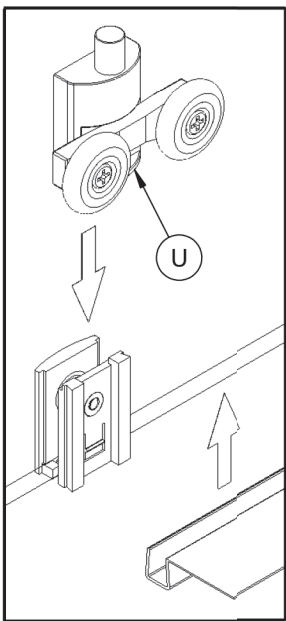
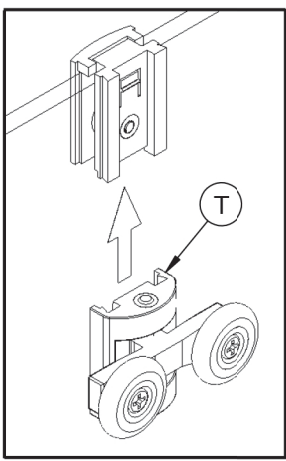
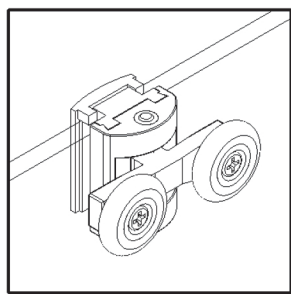

● Intérieur ● Inside
 ● Interior ● Interno
 ● Binnenkant ● Innen
 ● Extérieur ● Outside
 ● Exterior ● Externo
 ● Buitenkant ● Außen

X

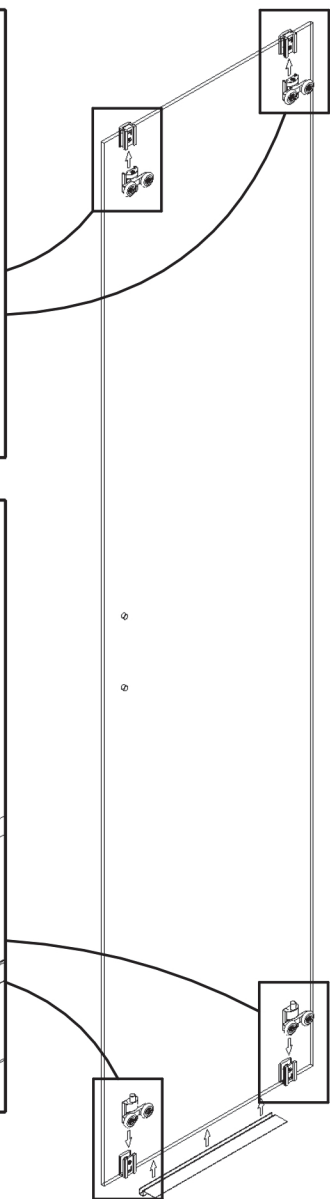

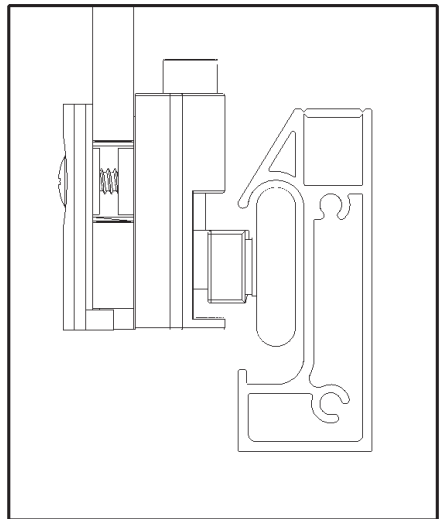
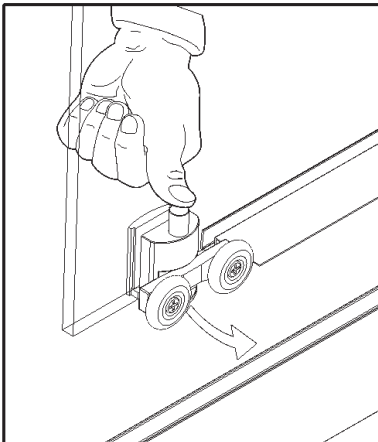
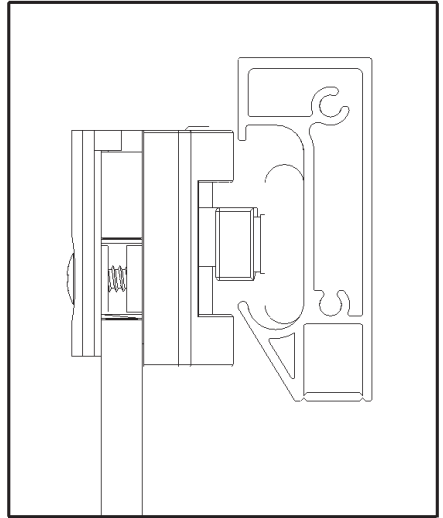
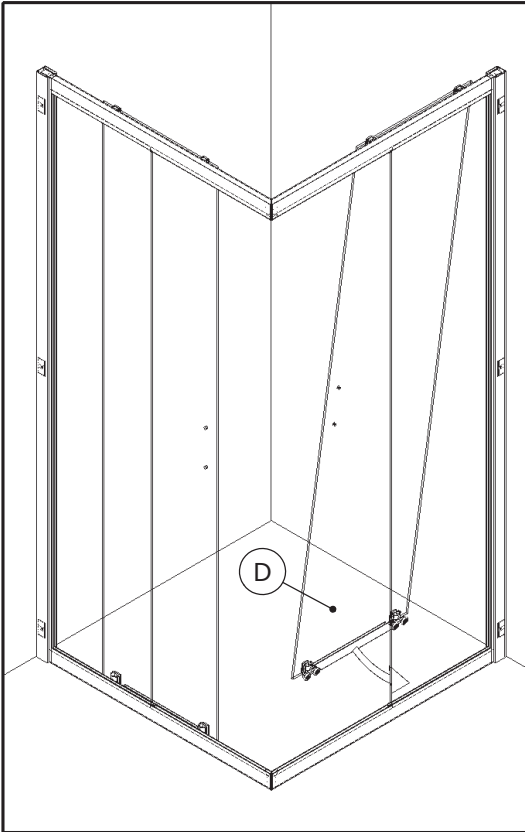

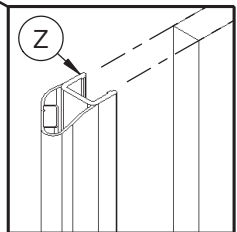
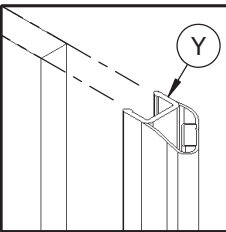
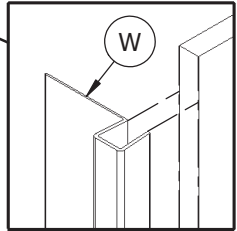
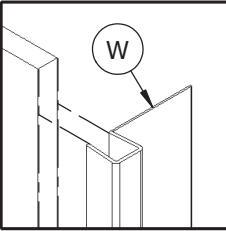
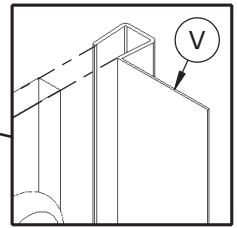
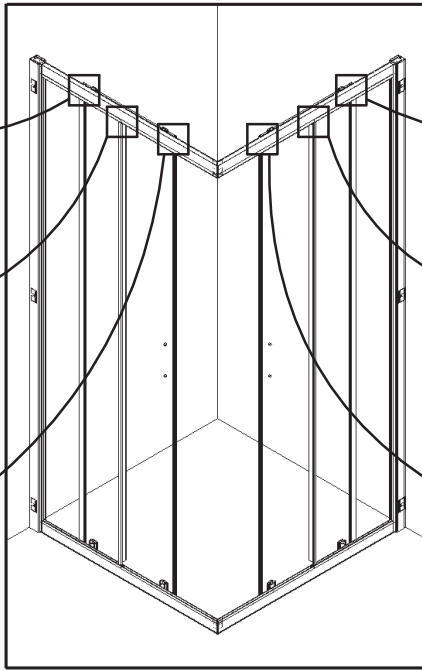
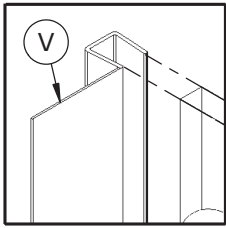

• Couper si nécessaire
 • Cut if necessary

• Recortar si necesario • Tagliare si necessario
 • Snijden indien nodig • Bei Bedarf zuschneiden

• Intérieur • Inside
 • Interior • Interno
 • Binnenkant • Innen

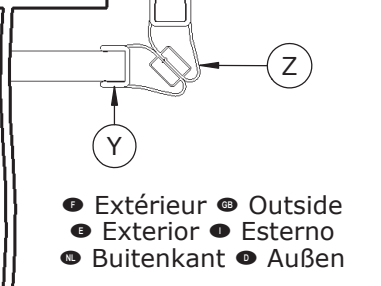
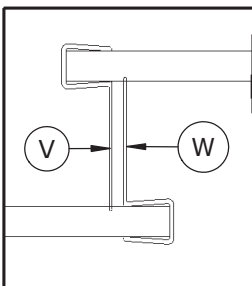
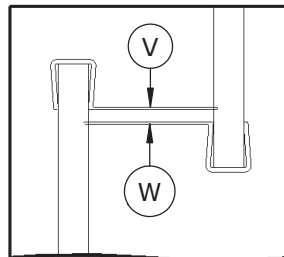

• Extérieur • Outside
 • Exterior • Esterno
 • Buitenkant • Außen

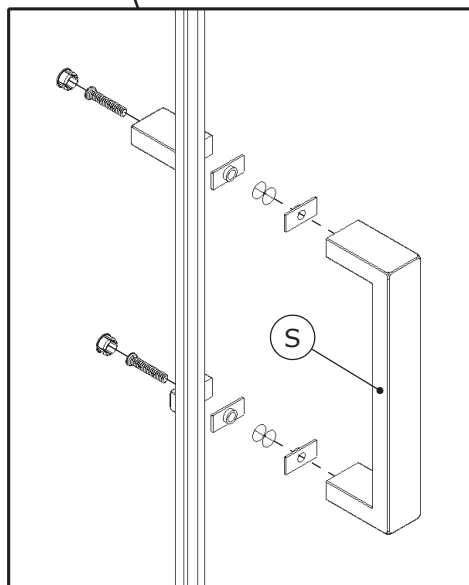
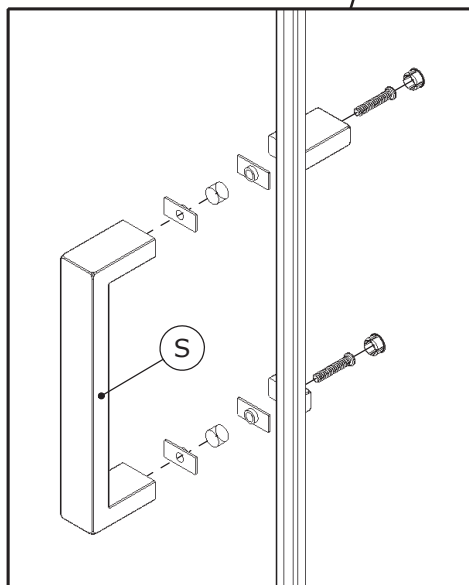
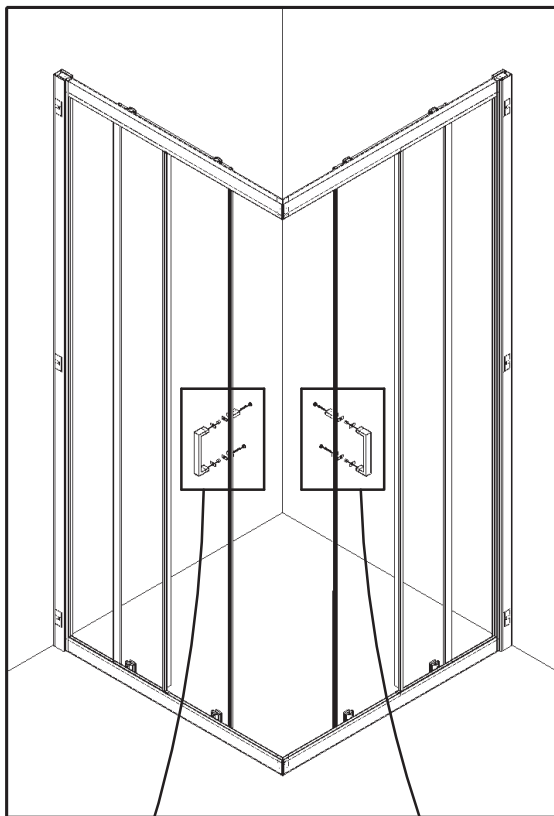

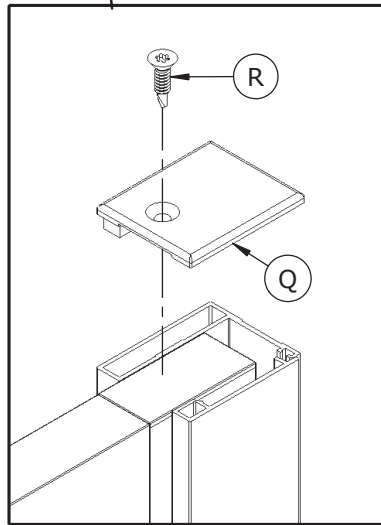
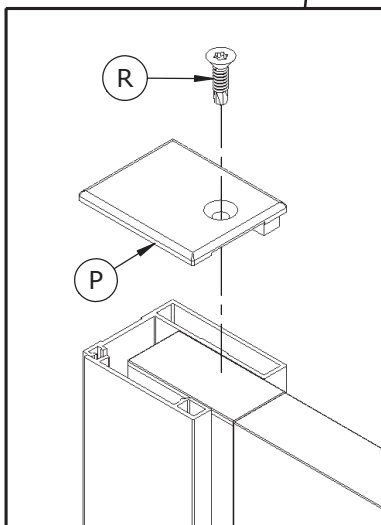
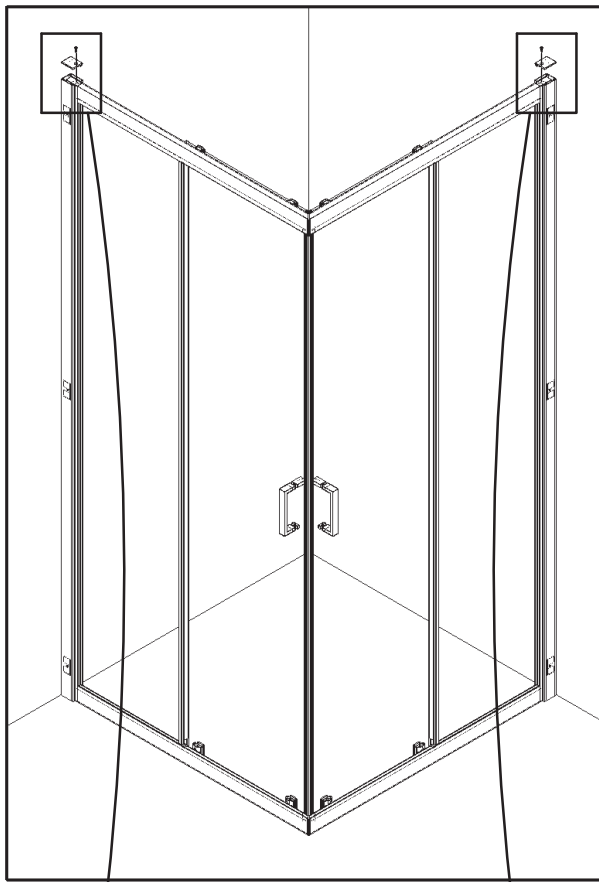

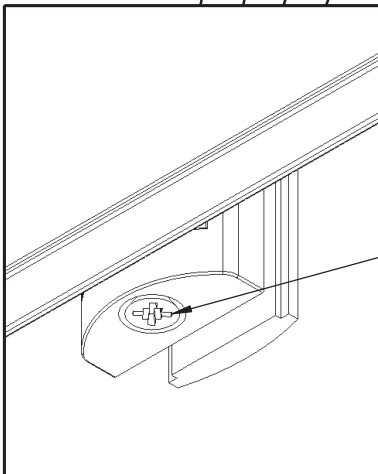
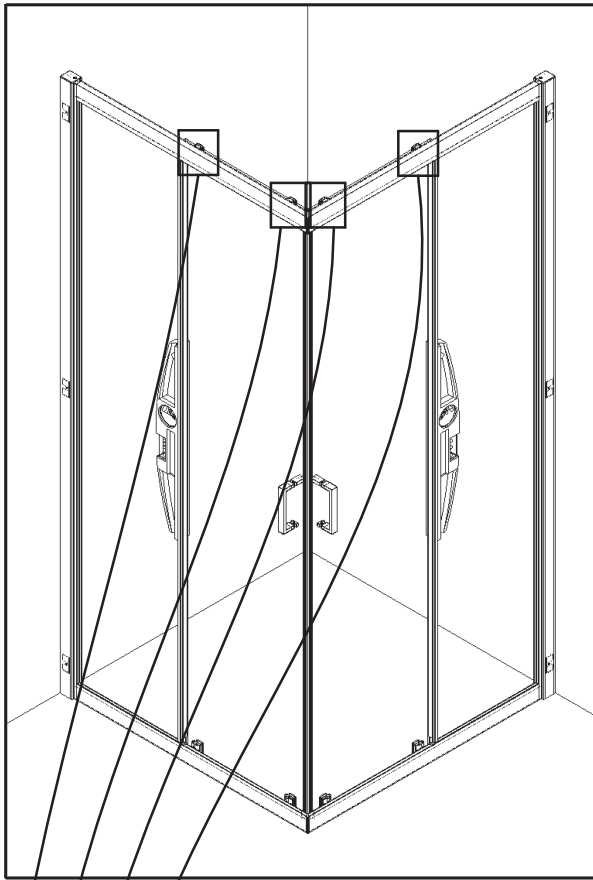

- ① Régler les portes afin qu'elles soient de niveau
- ② Adjust the doors so that they are level
- ③ Ajustar las puertas de manera que estén niveladas
- ④ Regolare le porte in modo che siano in bolla
- ⑤ Stel de deuren zodanig af zodat ze waterpas staan
- ⑥ Türen waagrecht ausrichten

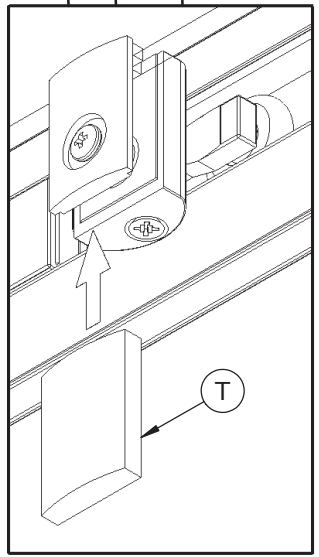
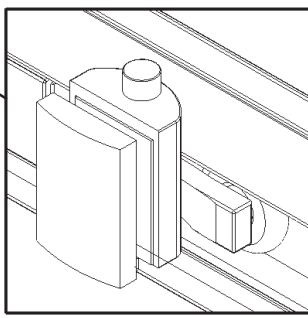
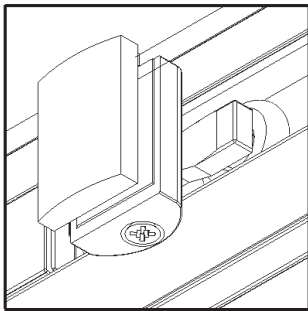
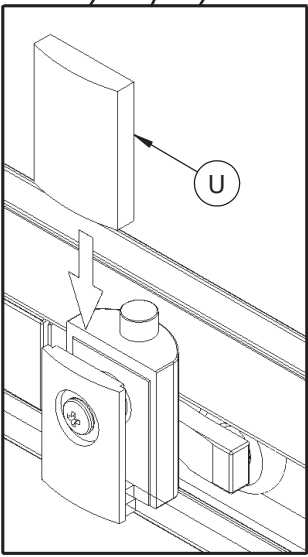
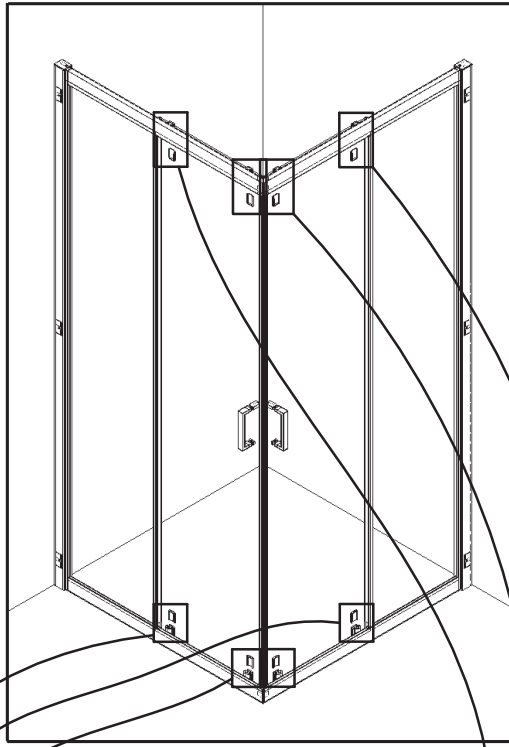

● F Vue intérieure ● S Interior view ● E Vista interior
● Vista interna ● NL Binnen aanzicht ● D Innenansicht

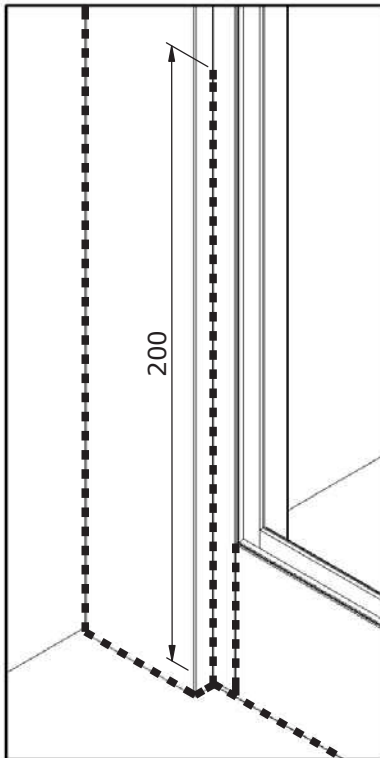
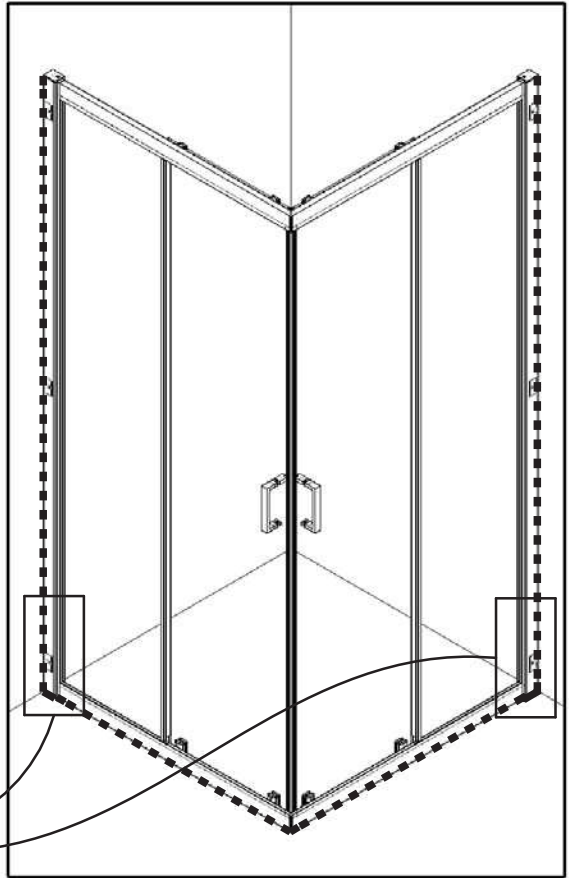
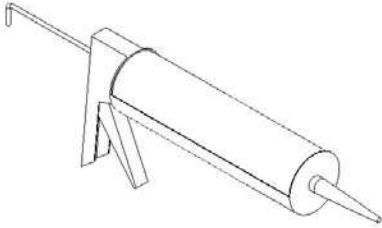

24H

INFO:

- Montage possible depuis l'intérieur de la douche
- Can be mounted from inside the shower
- Puede montarse desde el interior de la ducha
- Può essere montato dall'interno della doccia
- Kan worden gemonteerd vanuit de douche
- Kann aus dem Inneren der Dusche montiert werden

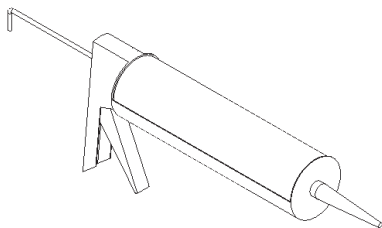
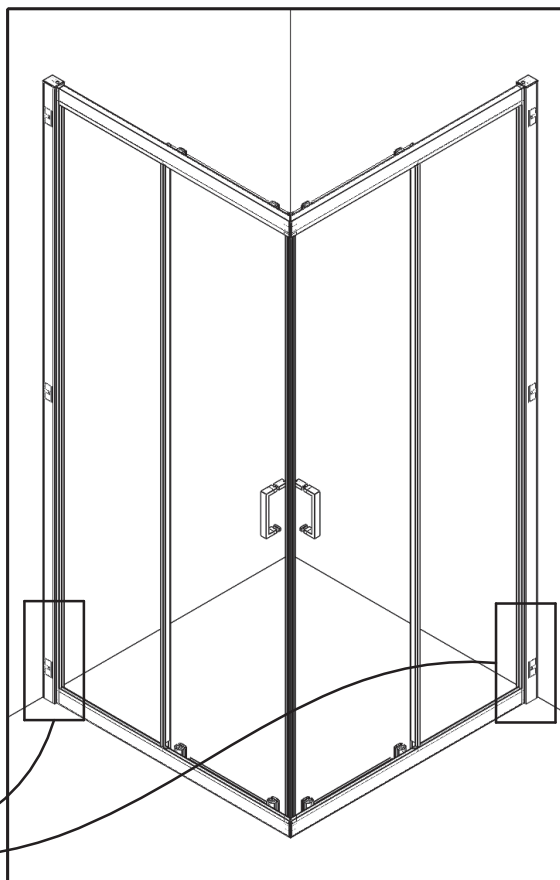
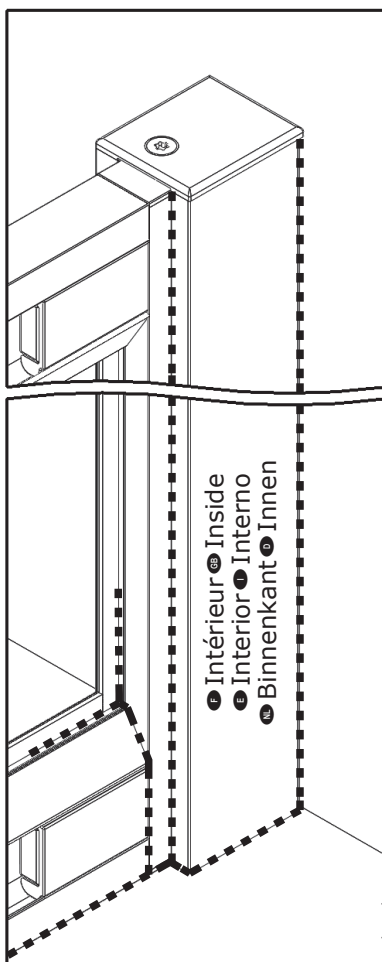
**24H**



AQUAPRODUCTION, Site industriel, F - 44680 Chéméré

18

EN 14428

Paroi de douche, fabriquée en verre de silicate
sodo-calcique de sécurité trempé thermiquement

Aptitude au nettoyage : réussite

Résistance à l'impact/propriétés de fragmentation : réussite

Durée : réussite



SAV
SERVICE HELPLINES
ASSISTENZA POST-VENDITA
SERVICIO POSTVENTA

FRANCE

02 40 21 29 45

SCHWEIZ

(01) 748 17 44

UK

020 8842 0033

ESPAÑA

93 544 60 76

IRELAND

04697 33102

NEDERLAND

0475 487 100

DEUTSCHLAND

+49 (0) 6074 / 30928 0

BELGIË

+31 475 487 100

ITALIA

(0382) 6181

BELGIQUE

+31 475 487 100

ÖSTEREICH

+43 1 710 60 70

РОССИЯ

963 19 40, 773 67 22