

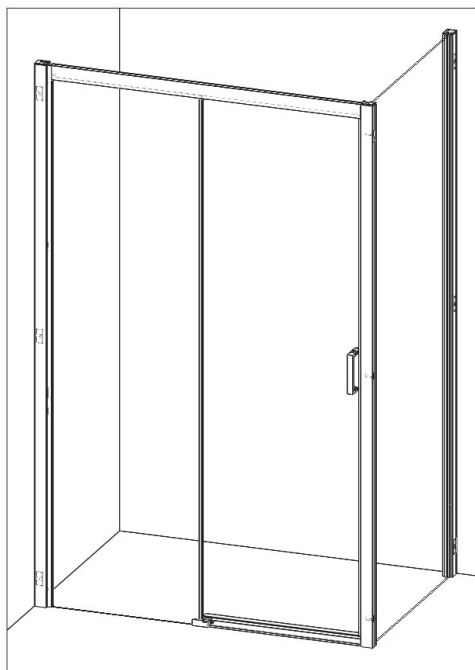

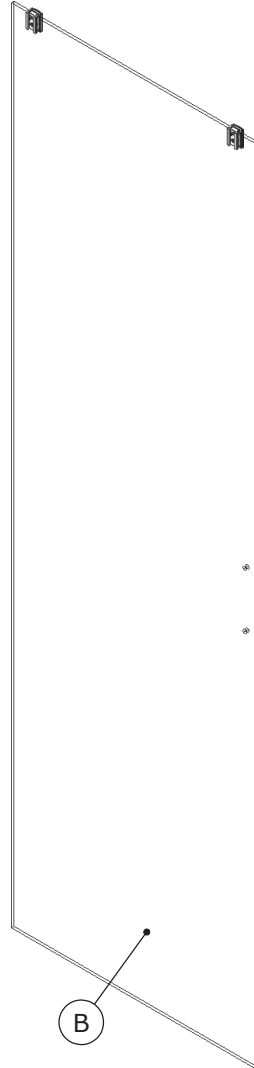

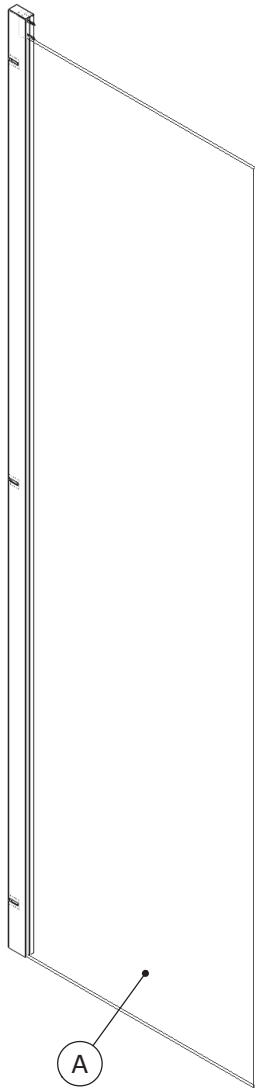

**F** Notice de montage **GB** Installation instructions  
**E** Manual de instalación **I** Istruzioni di montaggio  
**NL** Montage-instructies **D** Montageanleitung

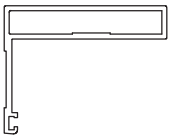
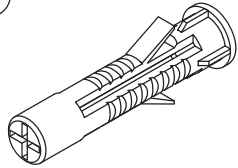
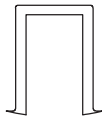
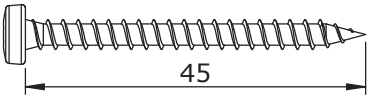
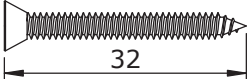

- F** Attention aux étapes :
- GB** Check installation steps :
- E** Atención a los pasos :
- I** Attenzione ai passi :
- NL** Aandacht voor de stappen :
- D** Achtung vor den Schritten :

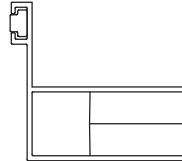
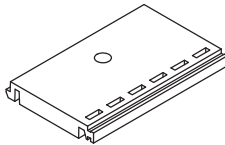
P. 8 - 13 - 29

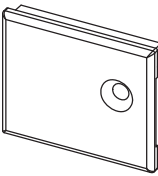
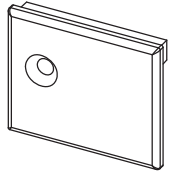
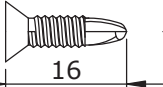
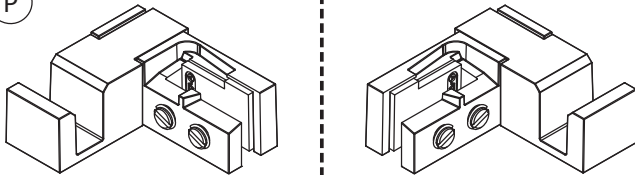
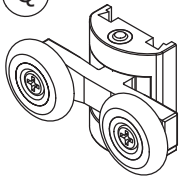
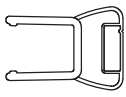

<p>D</p>  <p>x2</p> <p>6242</p>	<p>E</p>  <p>x6</p> <p>CHE02</p>	<p>F</p>  <p>x1</p> <p>JOI301</p>
<p>G</p>  <p>Ø4</p> <p>45</p> <p>x6</p> <p>1=1</p> <p>VIS231</p>	<p>H</p>  <p>Ø3.5</p> <p>32</p> <p>x6</p> <p>1=1</p> <p>VIS255</p>	
<p>I</p>  <p>x1</p> <p>6248E</p>	<p>J</p>  <p>x1</p> <p>6249E</p>	<p>K</p>  <p>x6</p> <p>PPL197</p>
<p>L</p>  <p>x2</p> <p>6243</p>	<p>M</p>  <p>x1</p> <p>PPL199</p>	<p>N</p>  <p>x1</p> <p>PPL200</p>
<p>O</p>  <p>Ø3.5</p> <p>16</p> <p>x2</p> <p>1=1</p> <p>VIS296</p>	<p>P</p>  <p>SET212</p> <p>SET213</p> <p>x1</p>	
<p>Q</p>  <p>x2</p> <p>ROU46</p>	<p>R</p>  <p>x1</p> <p>Lg=1856mm</p> <p>AI193</p>	<p>S</p>  <p>x1</p> <p>Lg=1873mm</p> <p>J889</p>

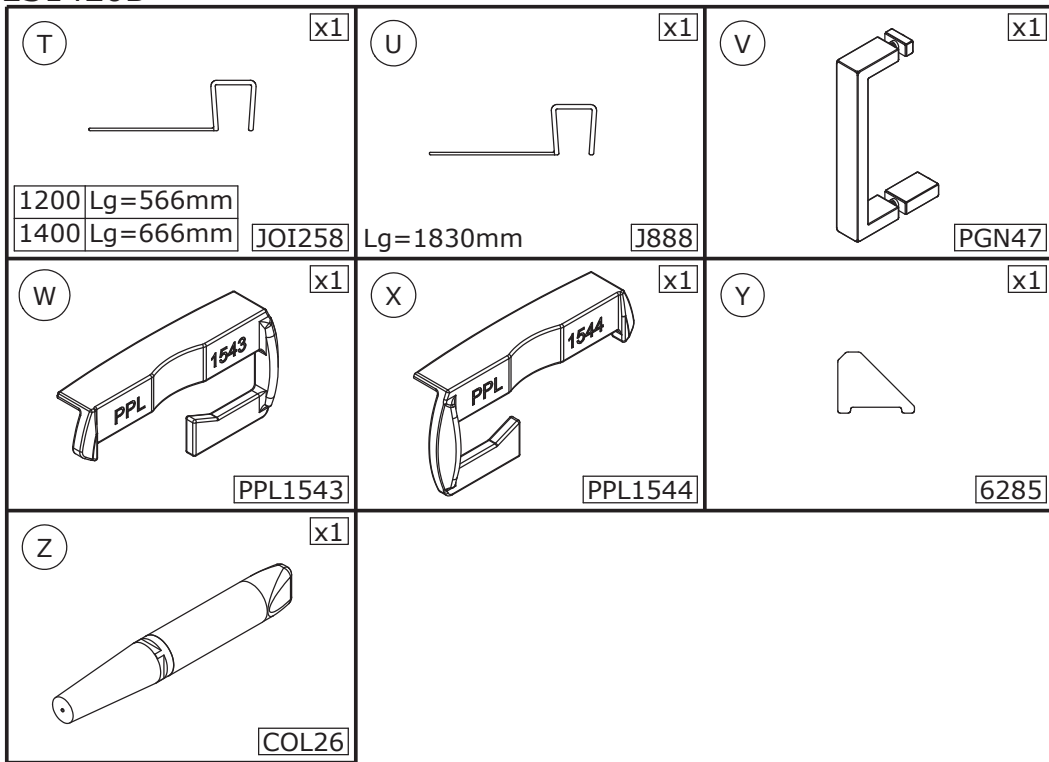

- Les quantités données sont les quantités utiles au montage. les sachets fournis contiennent des pièces supplémentaires.
  - The quantities given are what are required for the installation. There may be some surplus in the package provide.
- Las cantidades indicadas son las cantidades necesarias para el montaje. Las bolsitas incluidas contienen piezas suplementarias.
  - Le quantità fornite sono le quantità necessarie al montaggio. I sacchetti forniti contengono pezzi supplementari.
  - De aangegeven aantallen zijn vereist voor de montage. De verpakking bevat extra onderdelen.
- Die Mengenangaben beziehen sich auf die für die Montage nötigen Teile. Eventuell weitere beige packte Teile ignorieren.

● Outillage nécessaire ● Tools required ● Equipamiento necesario  
 ● Attrezzatura necessaria ● Benodigde gereedschap ● Werkzeuge erforderlich

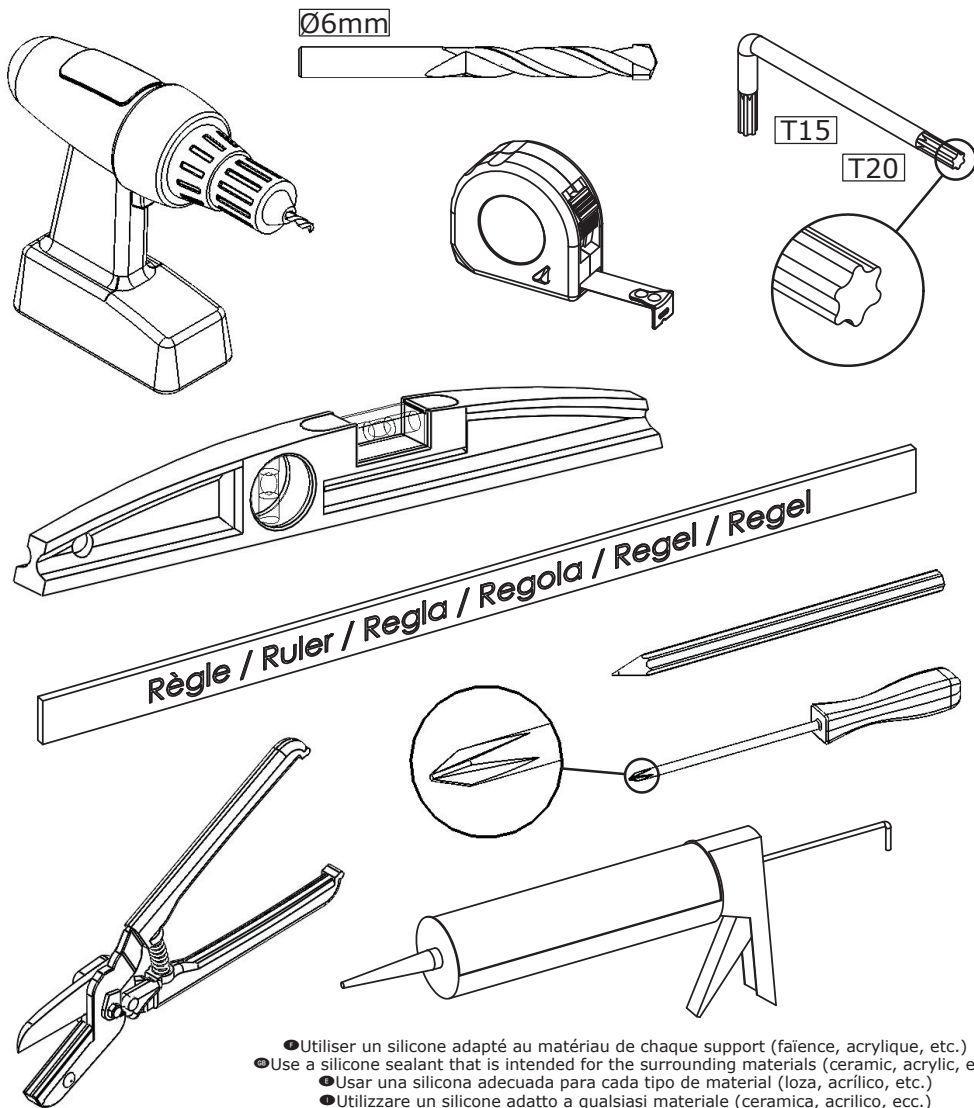

- Utiliser un silicone adapté au matériau de chaque support (faïence, acrylique, etc.)
- Use a silicone sealant that is intended for the surrounding materials (ceramic, acrylic, etc.)
- Usar una silicona adecuada para cada tipo de material (loza, acrílico, etc.)
- Utilizzare un silicone adatto a qualsiasi materiale (ceramica, acrilico, ecc.)
- Gebruik siliconenkit die geschikt is voor iedere ondergrond (tegelwerk, acryl, etc.)
- Für das jeweilige Trägermaterial (Stein, Acryl usw.) geeignetes Silikon verwenden.



● Réversibilité ● Reversibility ● Reversibilidad  
 ● Reversibilida ● Omkeerbaarheid ● Wahlweise Montage

● Montage à gauche  
 ● Left hand  
 ● Montaje a la izquierda  
 ● Montaggio a sinistra  
 ● Montage links  
 ● Montage links

● Montage à droite  
 ● Right hand  
 ● Montaje a la derecha  
 ● Montaggio a destra  
 ● Montage rechts  
 ● Montage rechts

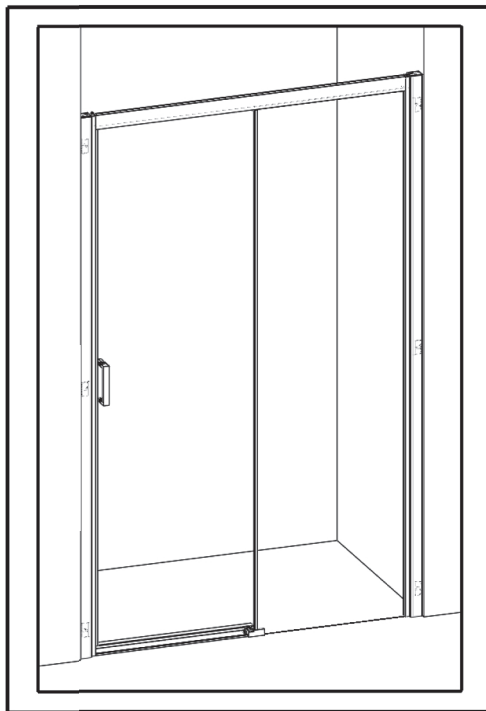
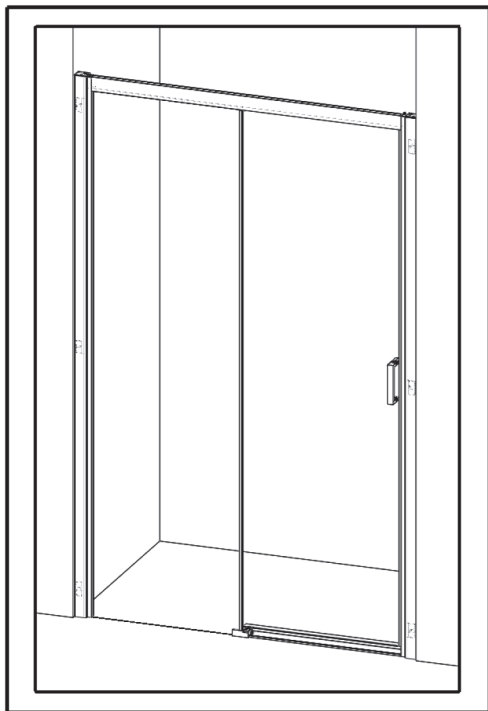

● Vous avez la possibilité de réaliser un montage à droite ou un montage à gauche. Notre notice d'installation décrit un montage à gauche. Si vous voulez réaliser un montage à droite, il vous suffit d'inverser le montage.

● This cubicle can be installed either left or right hand. These installation instructions show a left hand installation.

● Puede realizar un montaje a la derecha o un montaje a la izquierda. Nuestro folleto de instalación describe un montaje a la izquierda. Si desea montar su cabina a la derecha sólo tendrá que realizar el montaje al contrario.

● Avete la possibilità di effettuare il montaggio a destra o a sinistra. Il nostro manuale descrive il montaggio a sinistra. Se volete realizzare il montaggio a destra è sufficiente invertire varie fasi di montaggio.

● U kunt de douchecabine rechts of links monteren. Onze handleiding beschrijft de links montage van de cabine. Keer de montage om als u de cabine rechts wilt monteren.

● Sie haben die Möglichkeit, eine Montage auf der linken Seite oder eine Montage auf der rechten Seite durchzuführen. Unsere Montageanleitung beschreibt eine Montage auf der linken Seite. Wenn Sie die Montage lieber auf der rechten Seite durchführen wollen, müssen Sie nur den Montageprozess umkehren.



- F Cas particulier : Montage par l'intérieur
- GB Special case : Mounting from the inside
- E Caso especial : Montaje desde el interior
- I Caso speciale : Montaggio dall'interno
- NL Speciaal geval : Montage van binnenuit
- D Sonderfall : Montage von innen

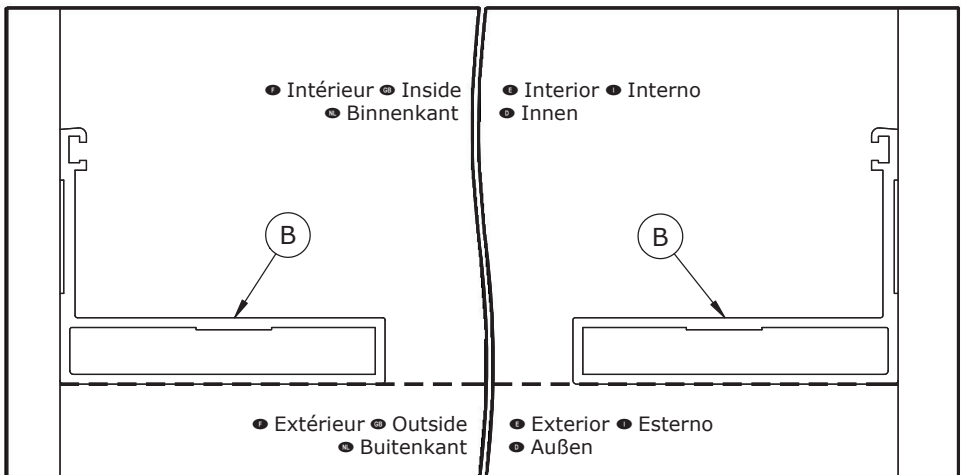
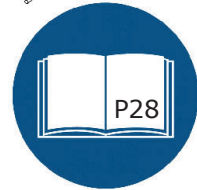
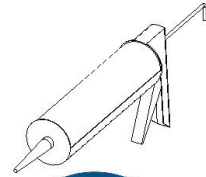
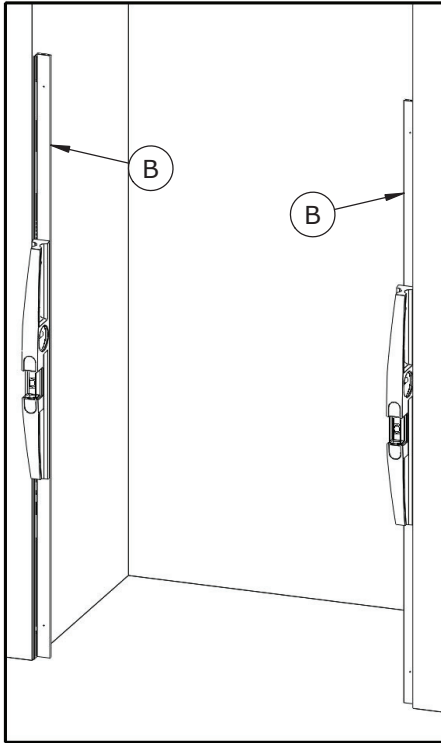

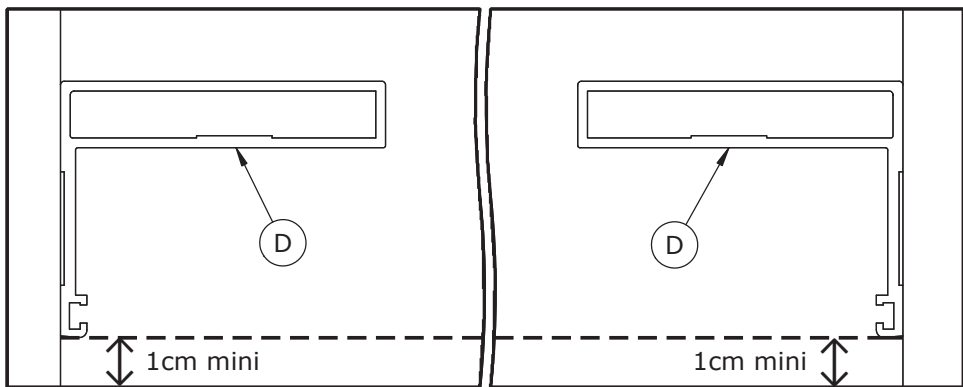
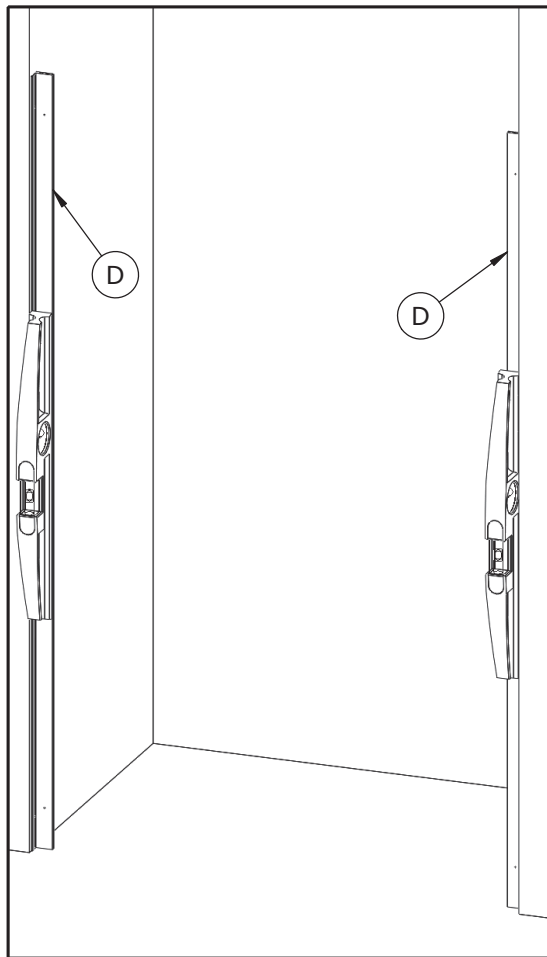



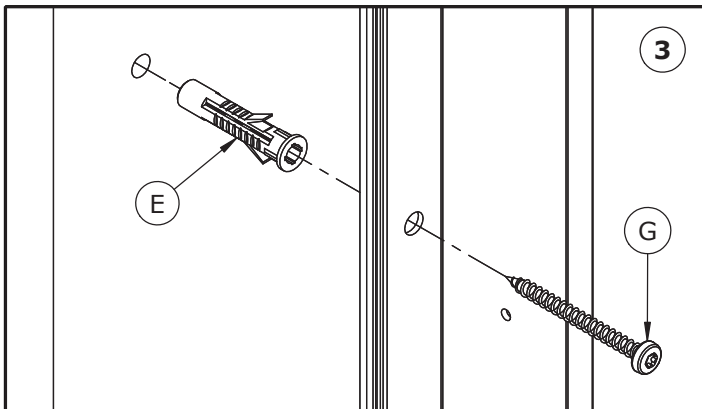
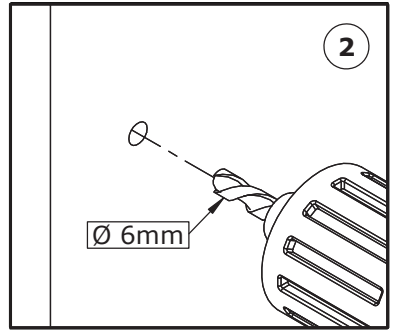
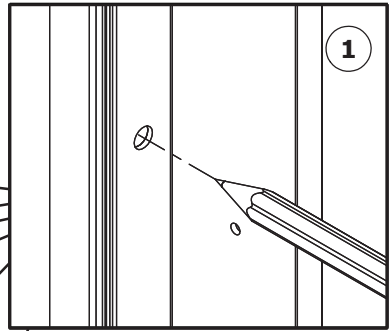
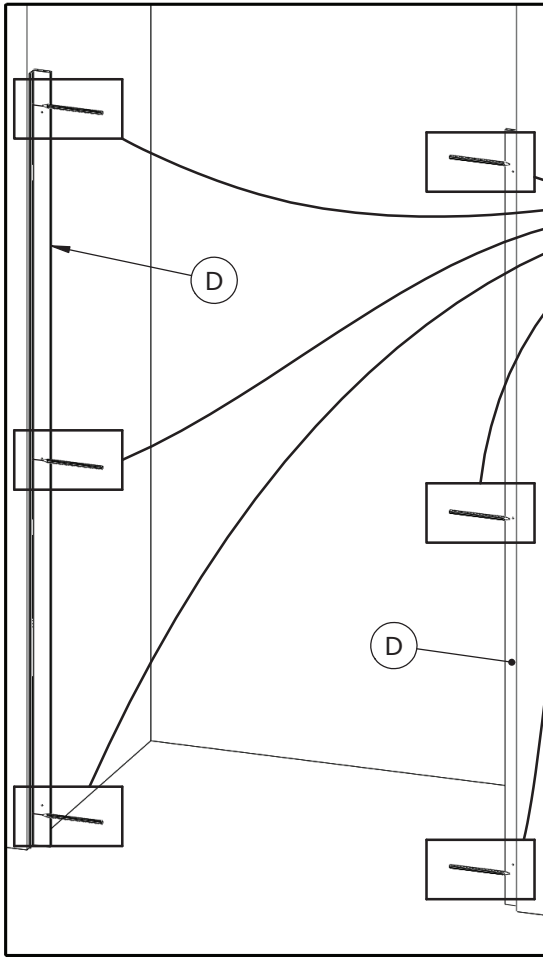

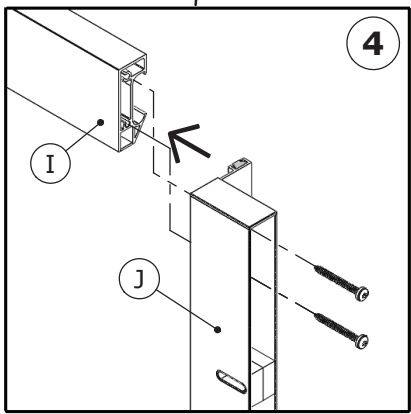
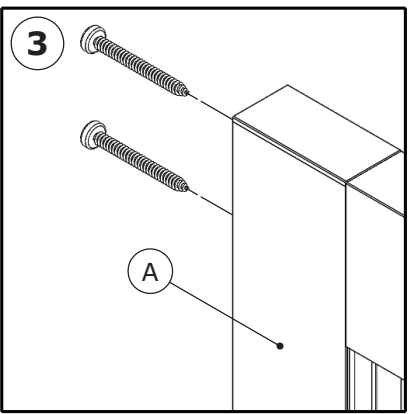
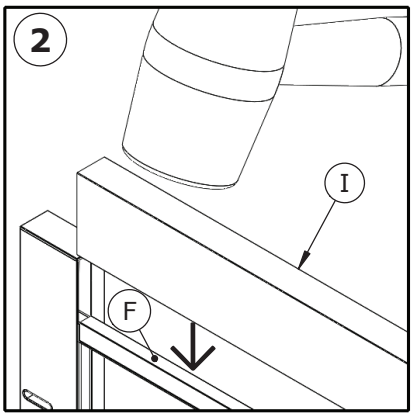
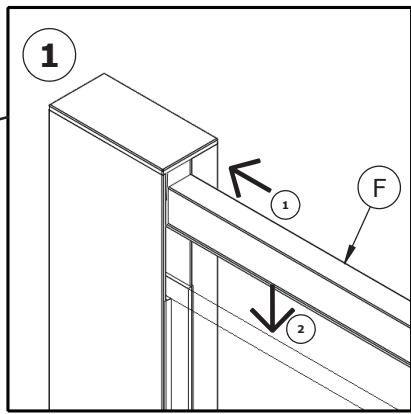
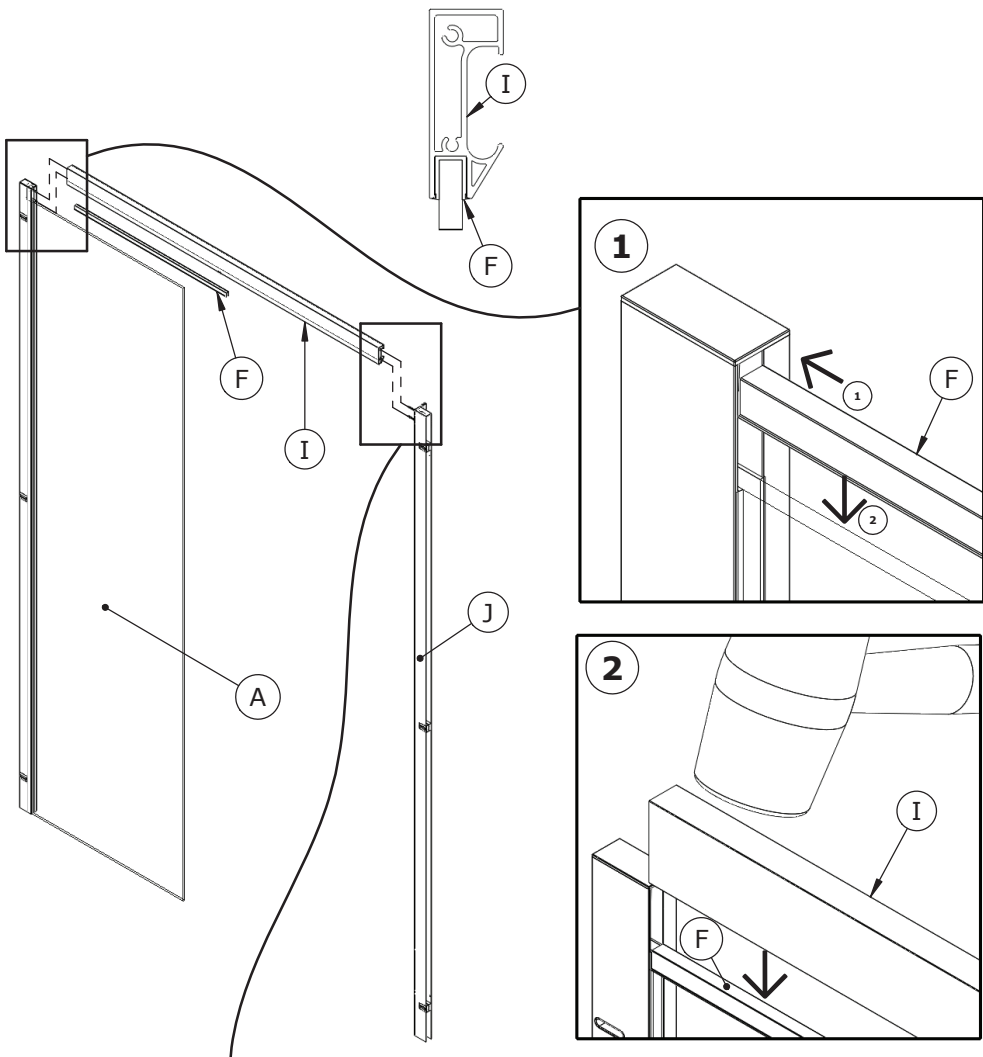

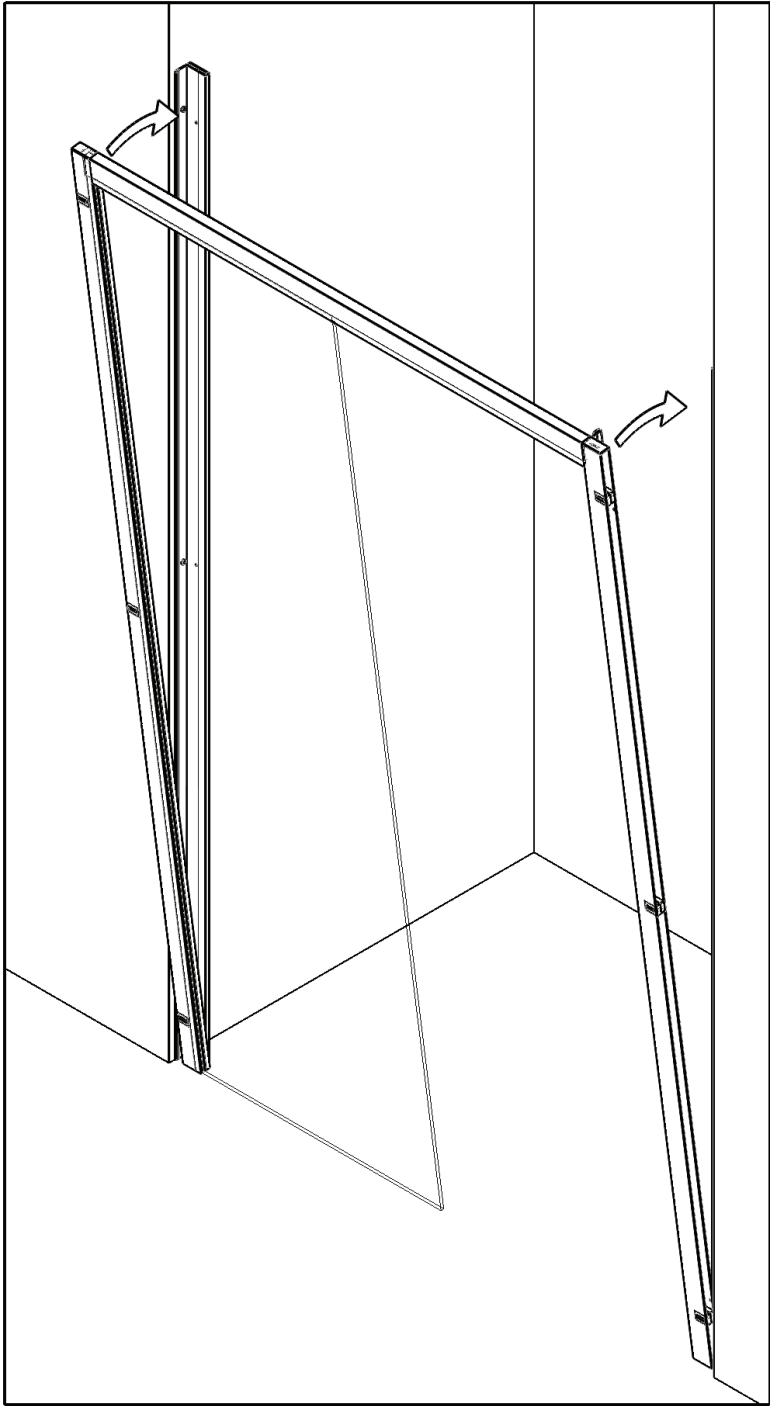

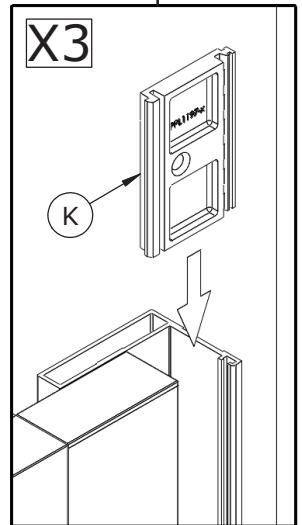
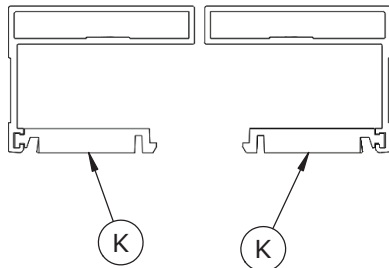
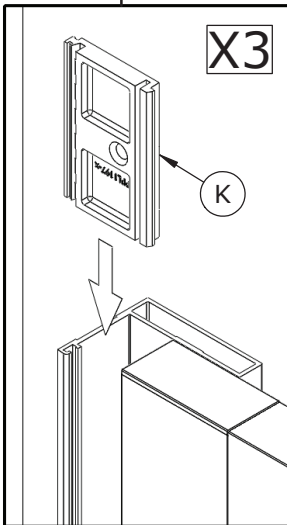
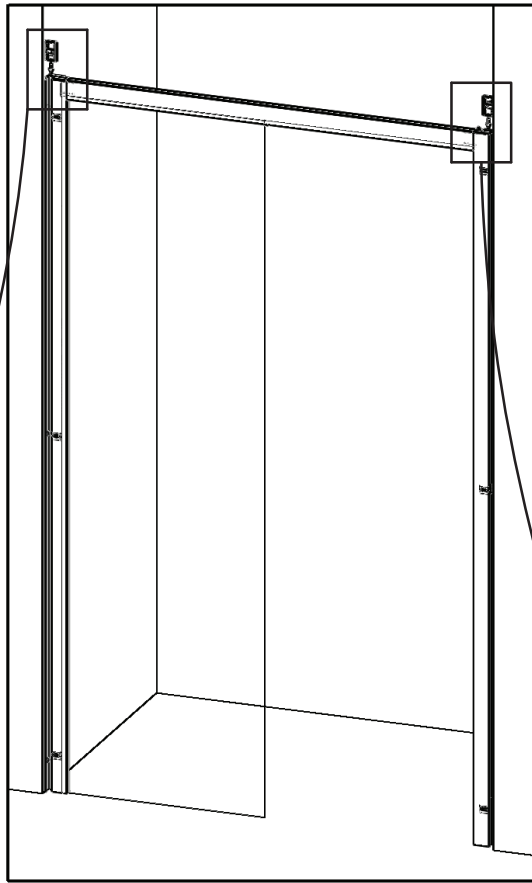

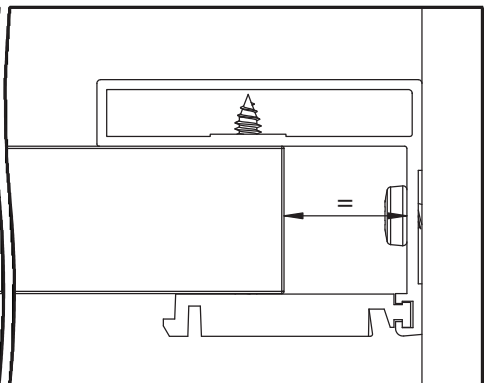
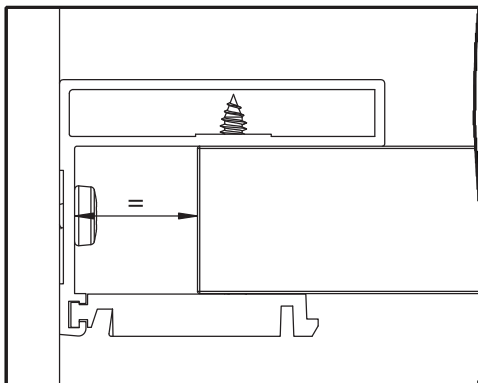
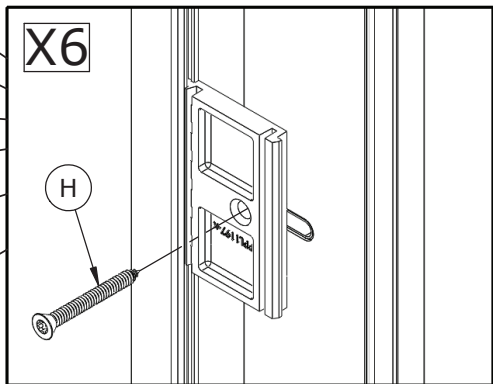
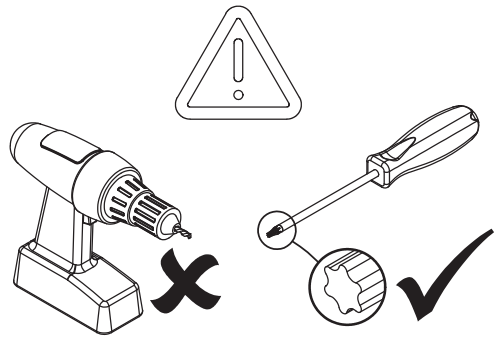
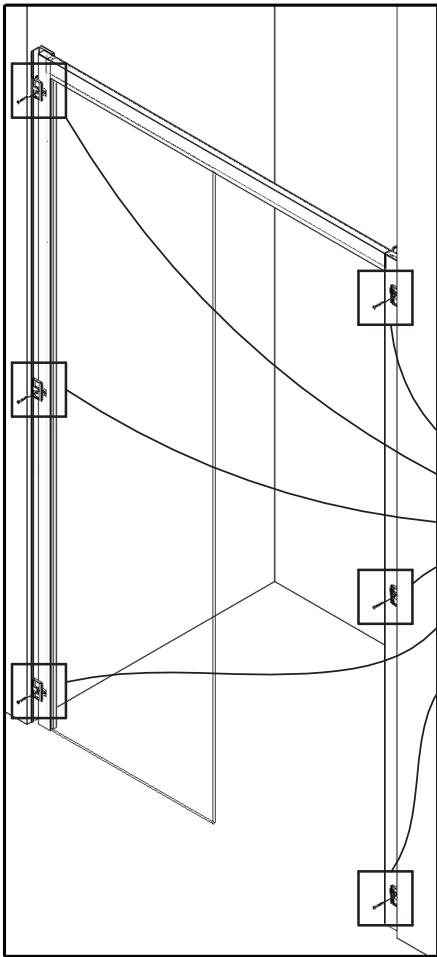

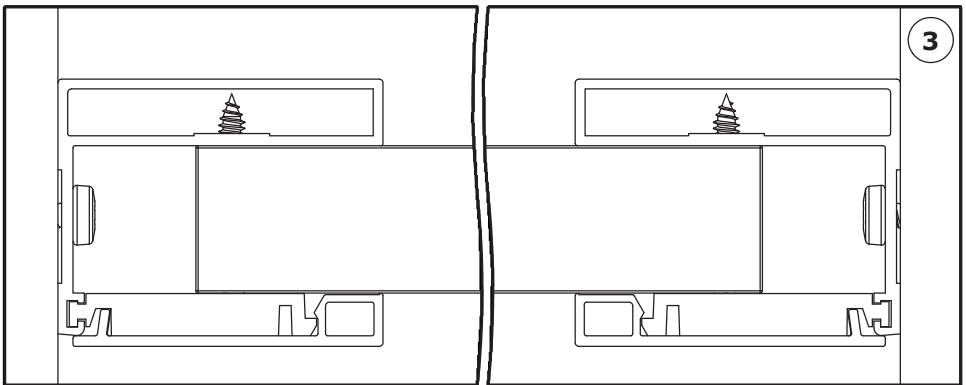
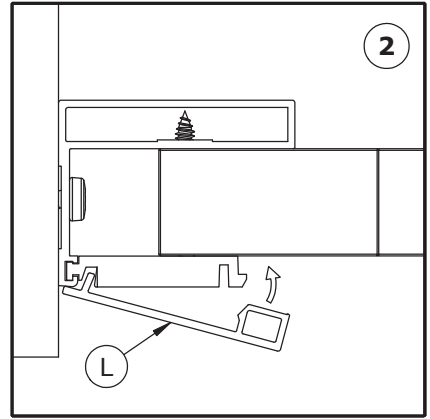
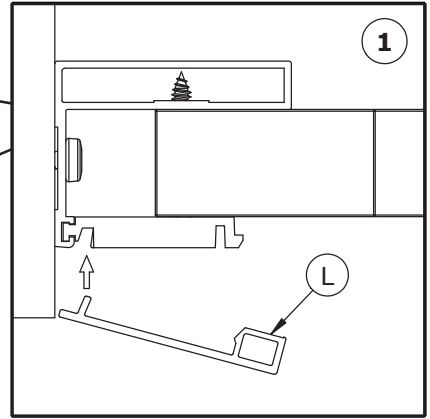
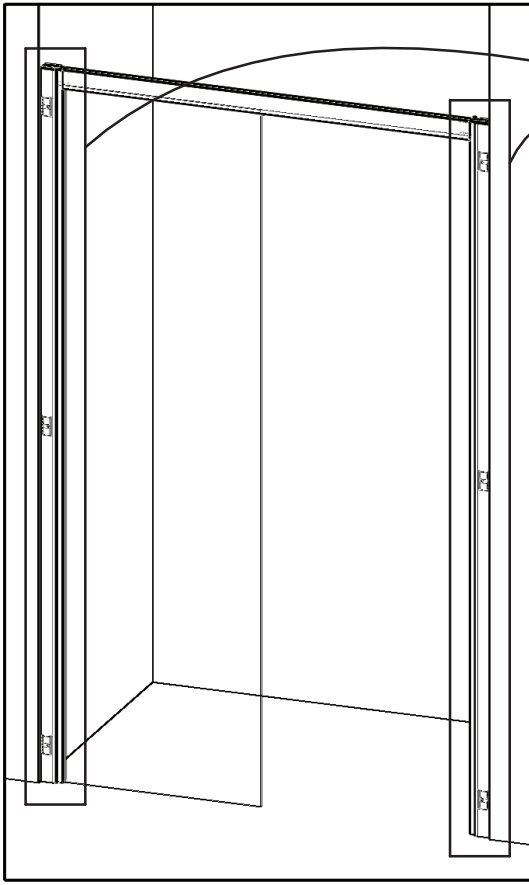

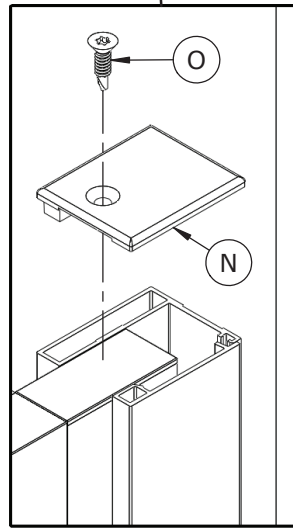
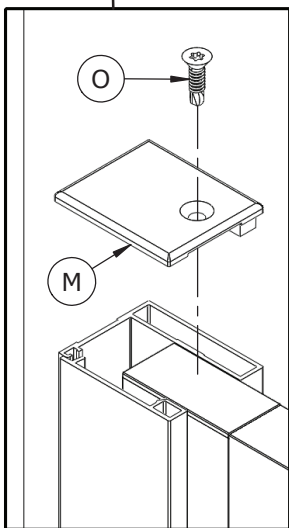
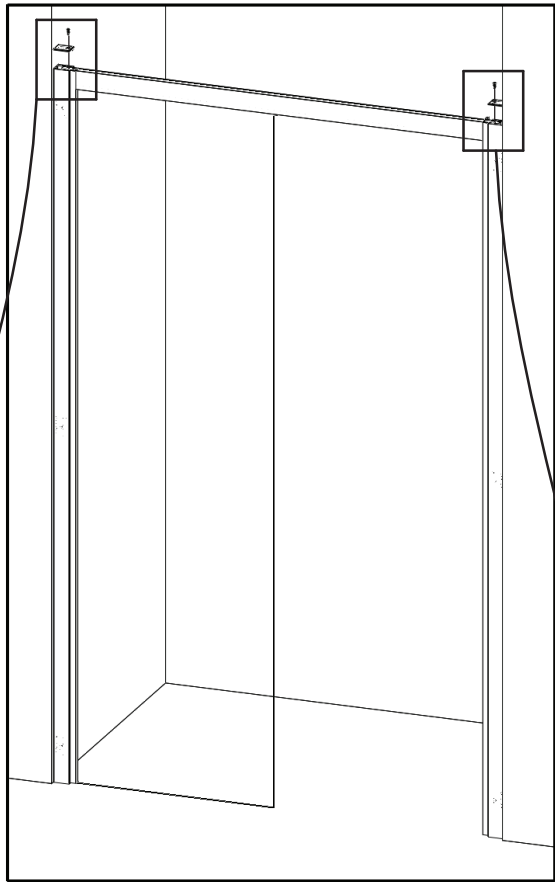

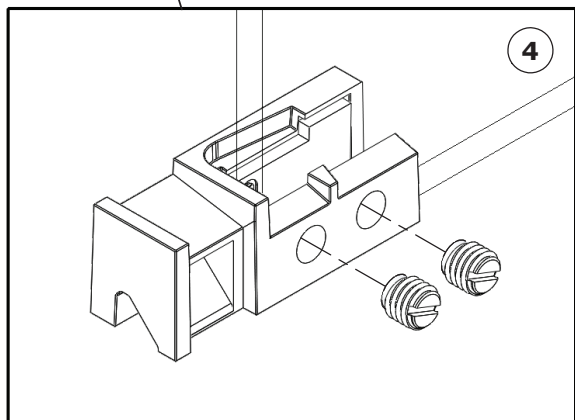
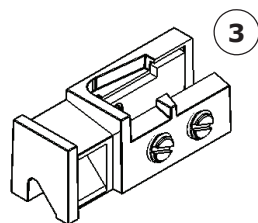
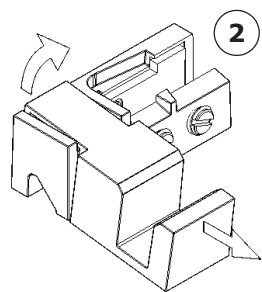
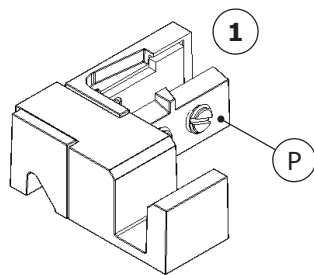
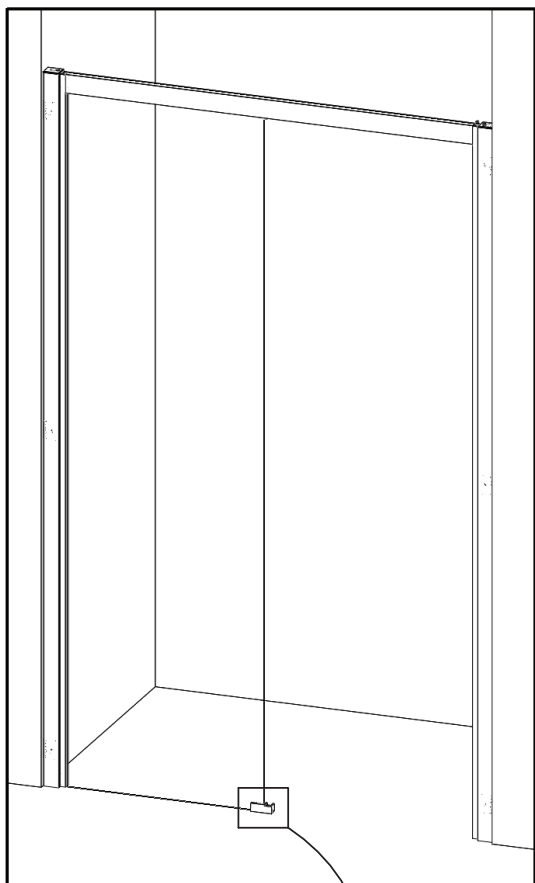

① Vue intérieur ② Interior view ③ Vista interior  
 ④ Vista interna ⑤ Binnen aanzicht ⑥ Innenansicht



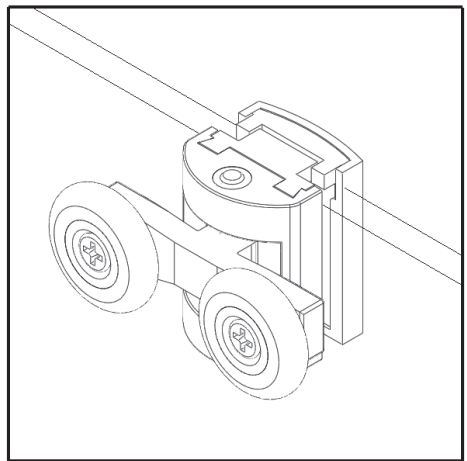
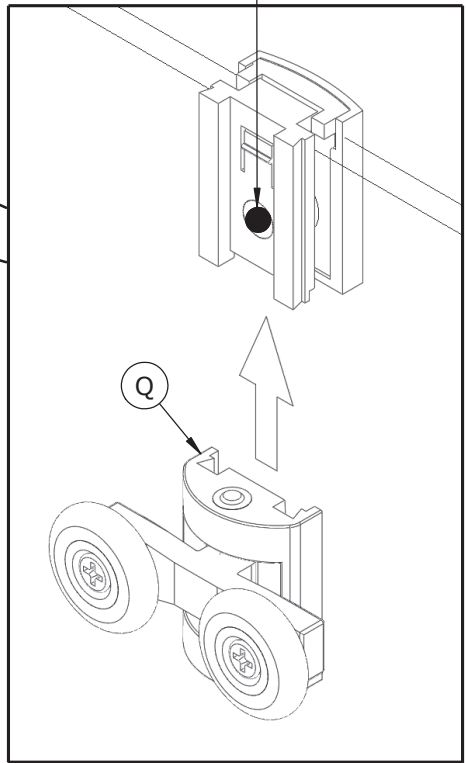
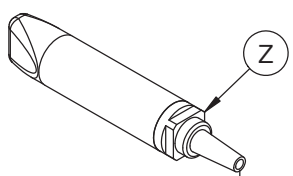
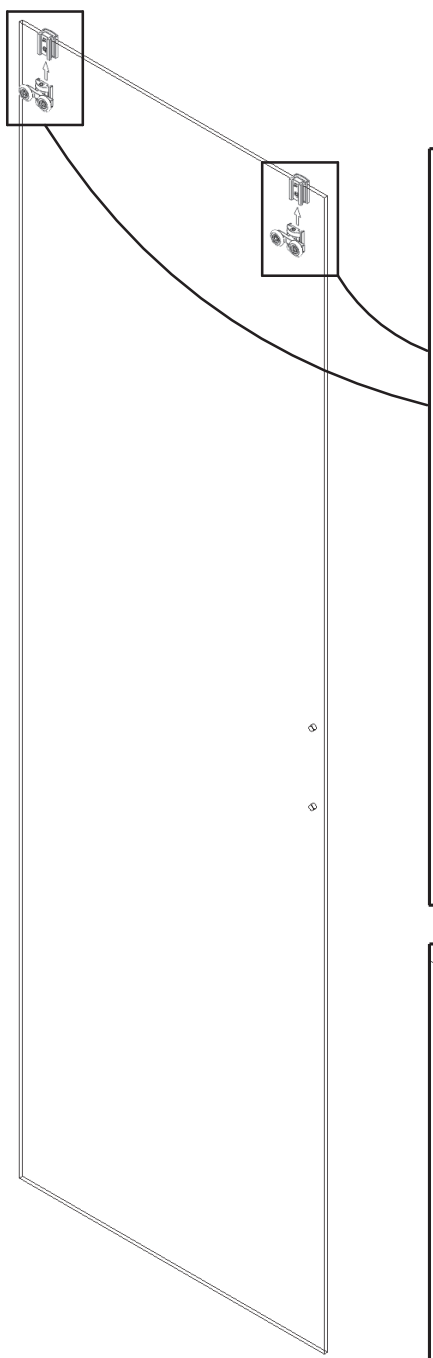

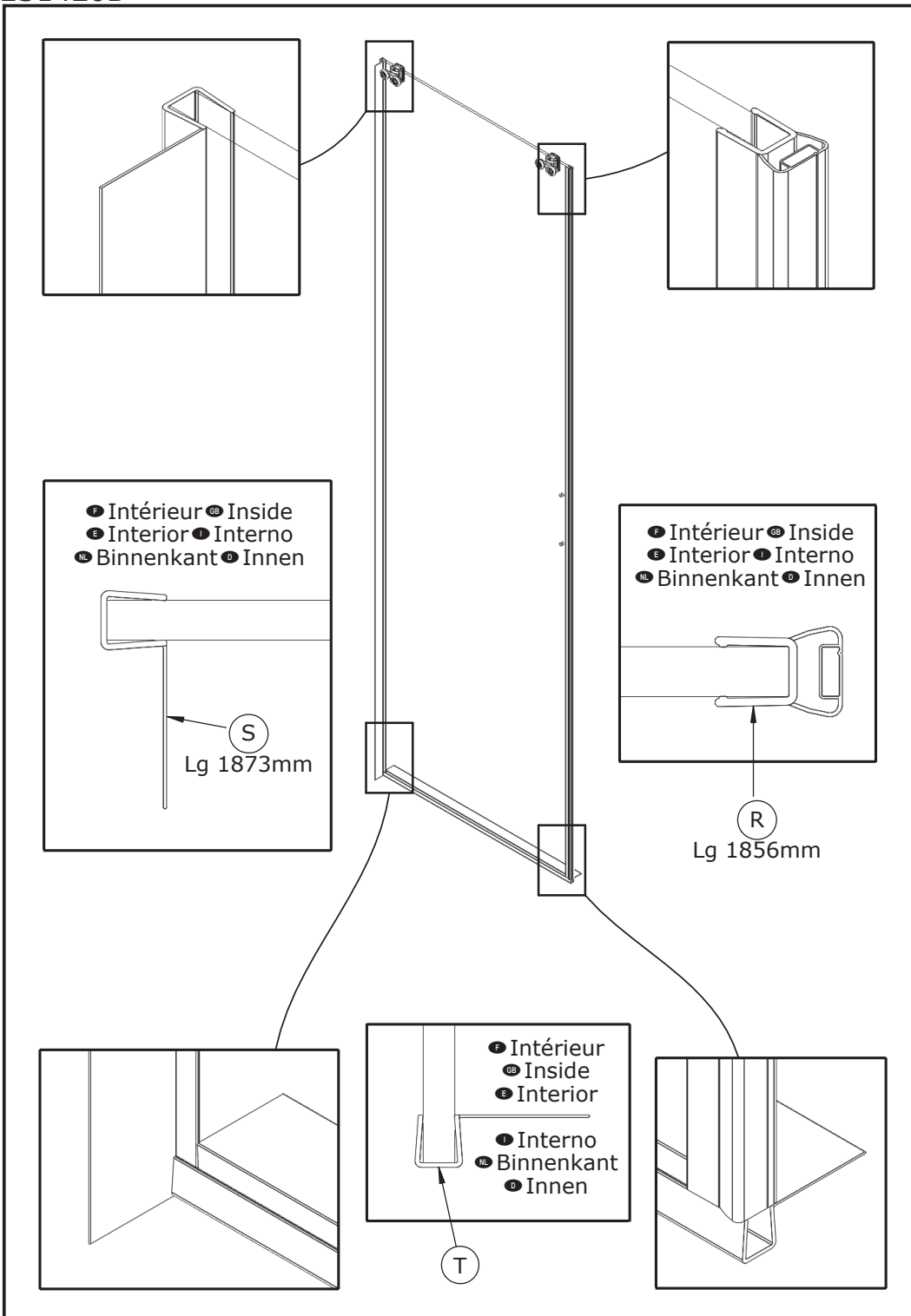

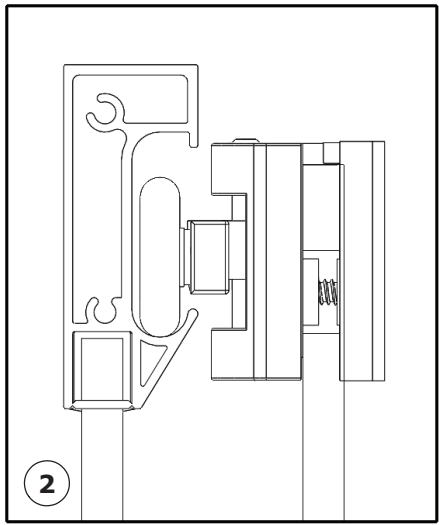
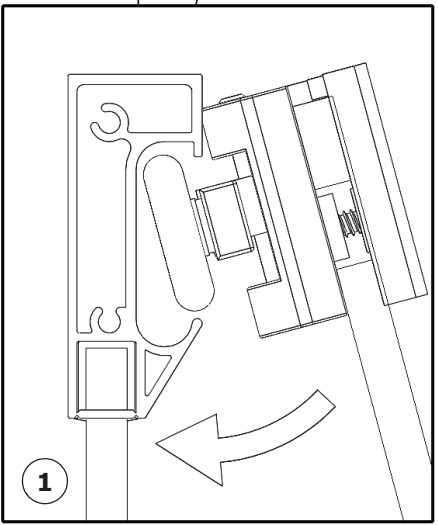
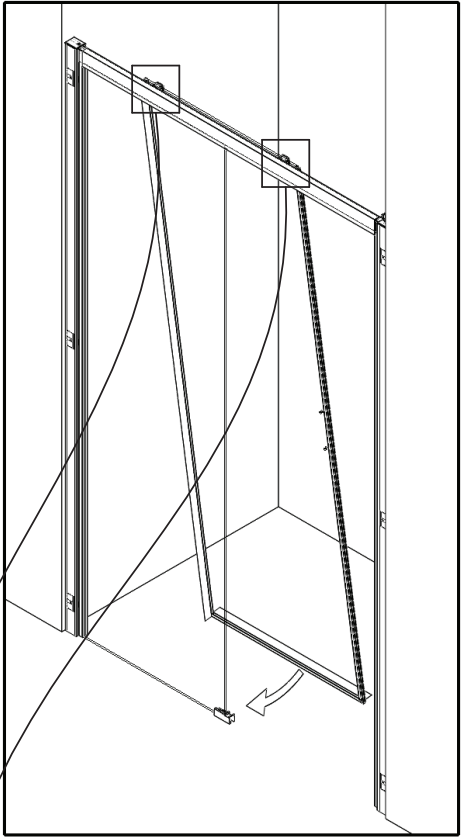

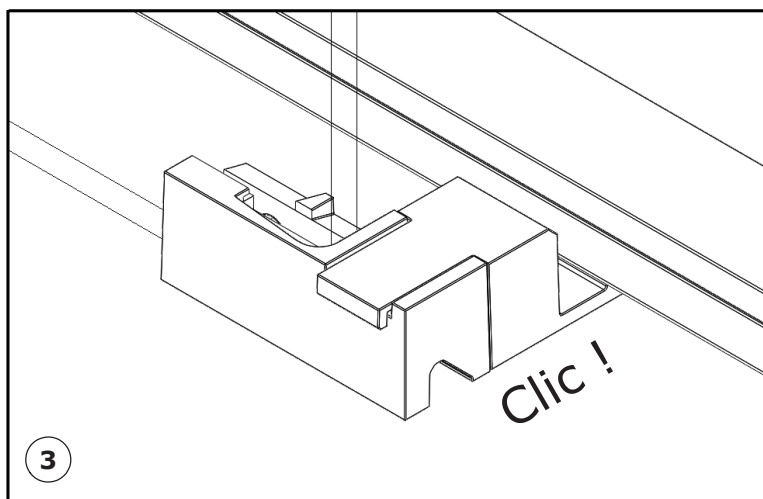
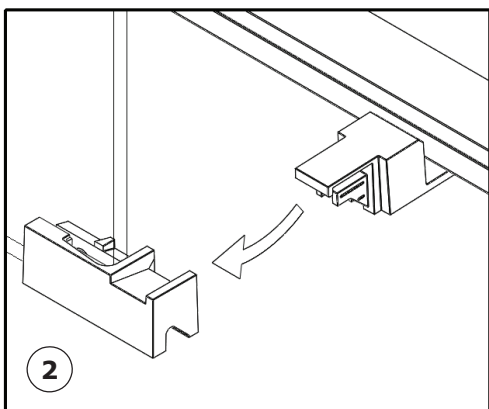
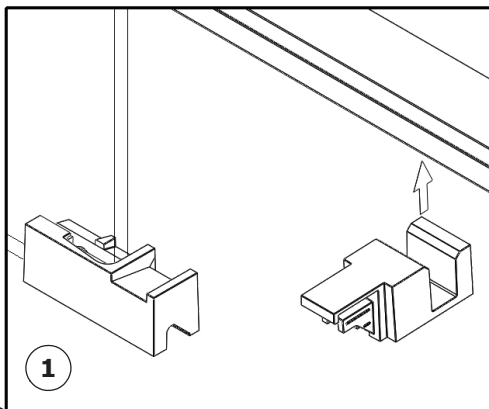
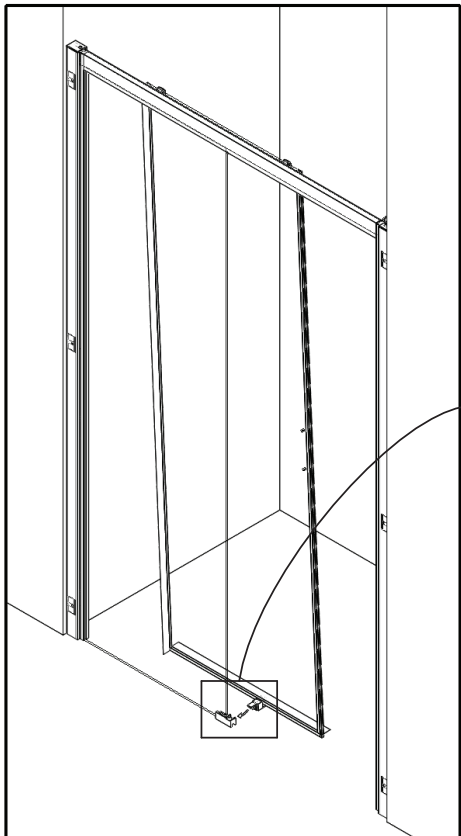

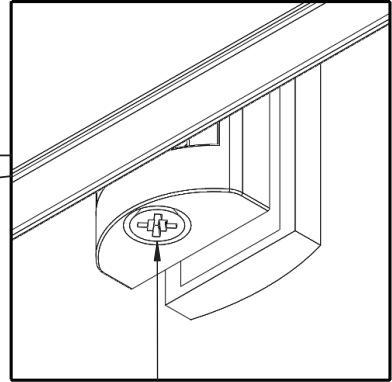
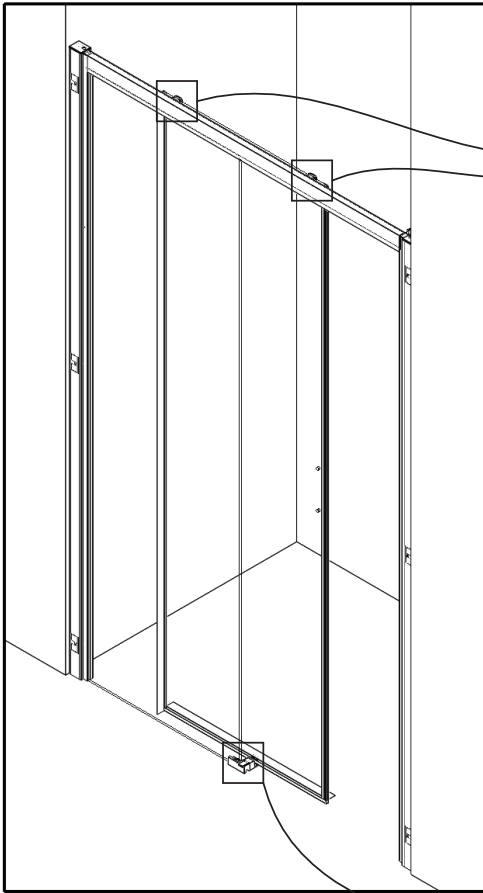

- Régler les portes afin qu'elles soient de niveau
- Adjust the doors so that they are level
- Ajustar las puertas de manera que estén niveladas
- Regolare le porte in modo che siano in bolla
- Stel de deuren zodanig af zodat ze waterpas staan
- Türen waagrecht ausrichten

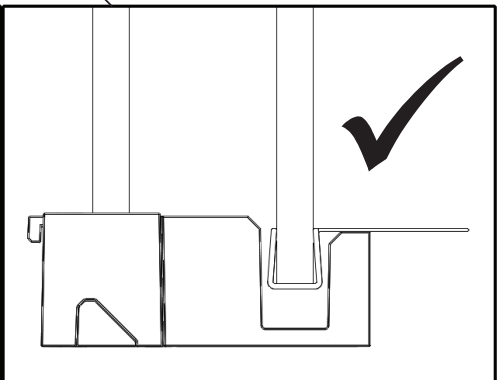
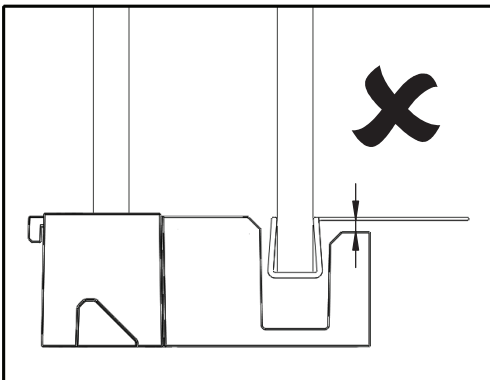

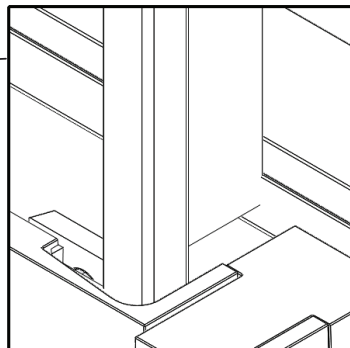
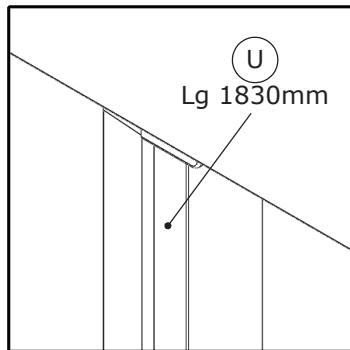
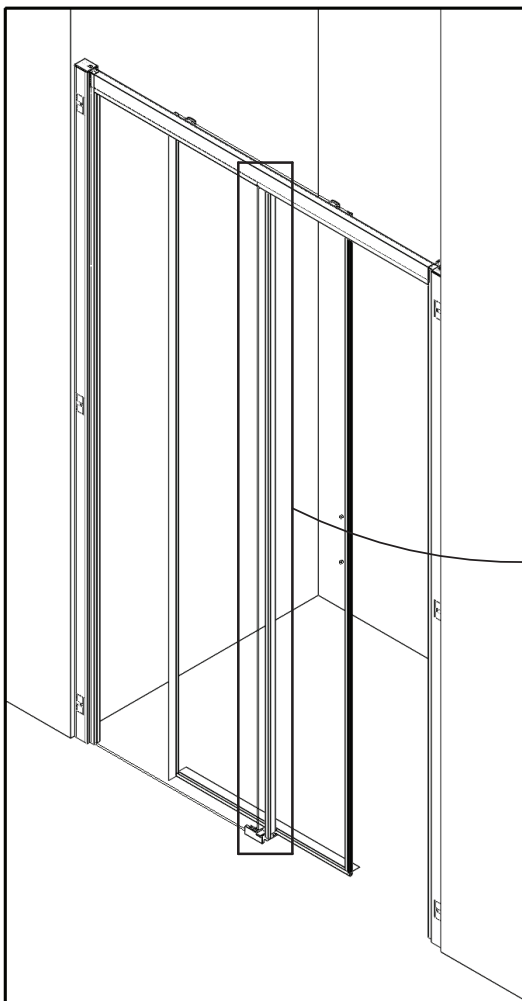

- Couper si nécessaire • Cut if necessary • Recortar si necesario
- Tagliare si necessario • Snijden indien nodig • Bei Bedarf zuschneiden

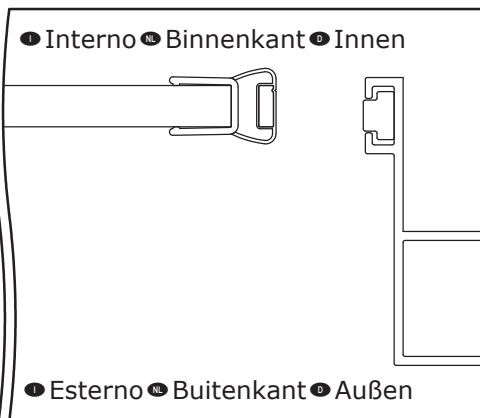
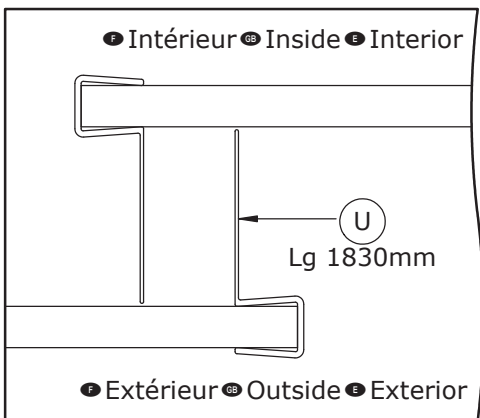

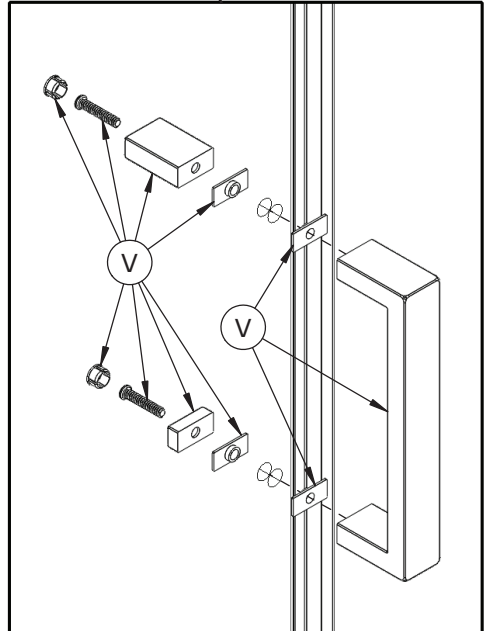
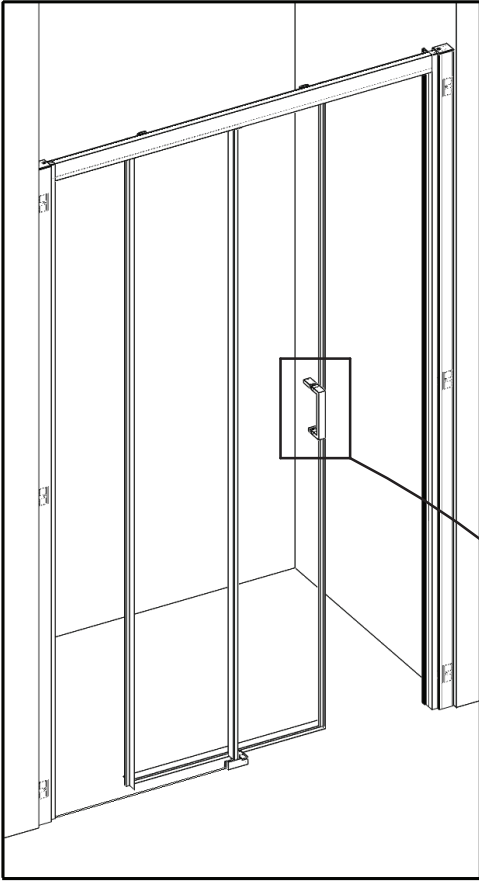

- Vue intérieur ● Interior view  
● Vista interior ● Vista interna  
● Binnen aanzicht ● Innenansicht

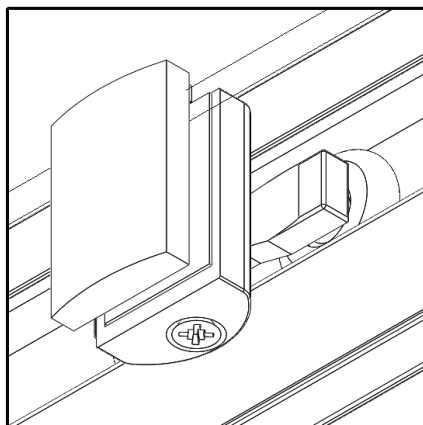
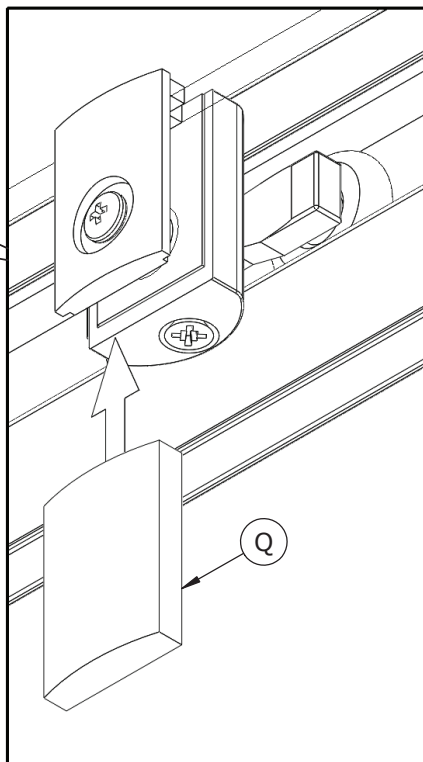
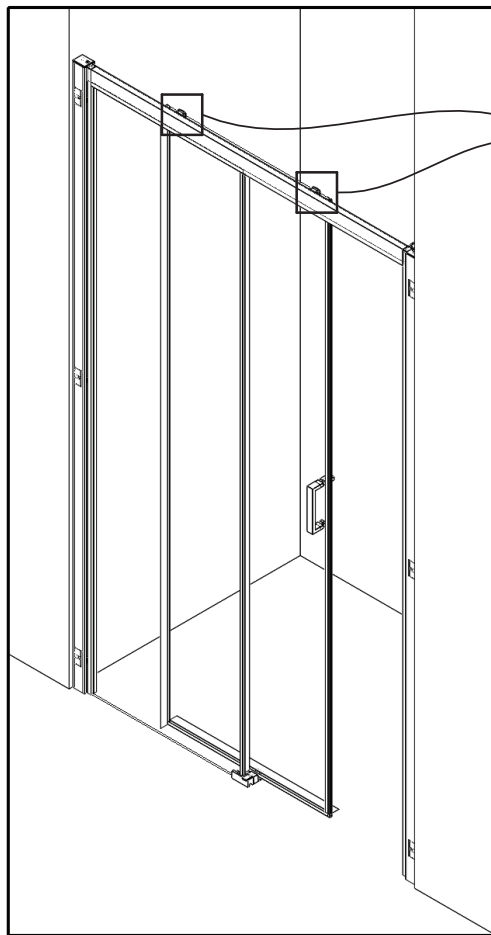



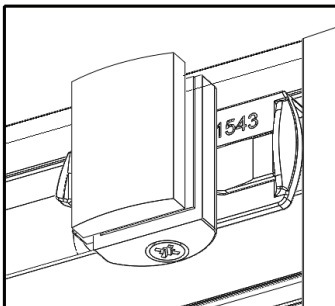
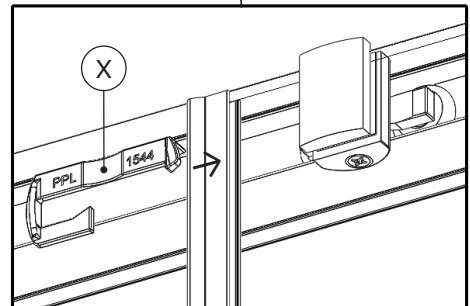
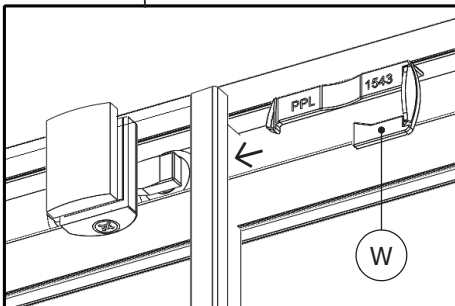
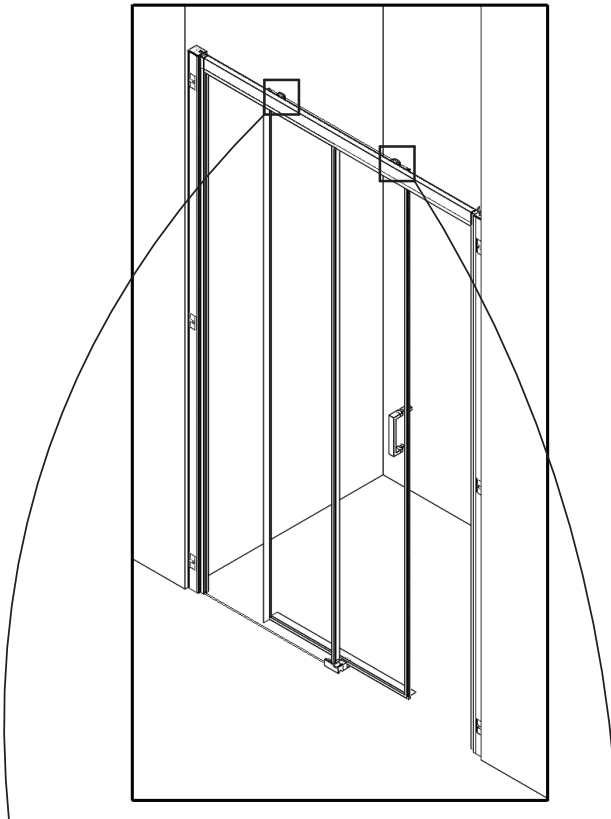

- Vue intérieur
- Interior view
- Vista interior
- Vista interna
- Binnen aanzicht
- Innenansicht

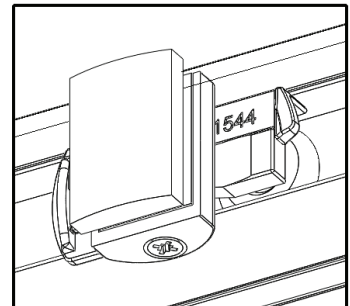

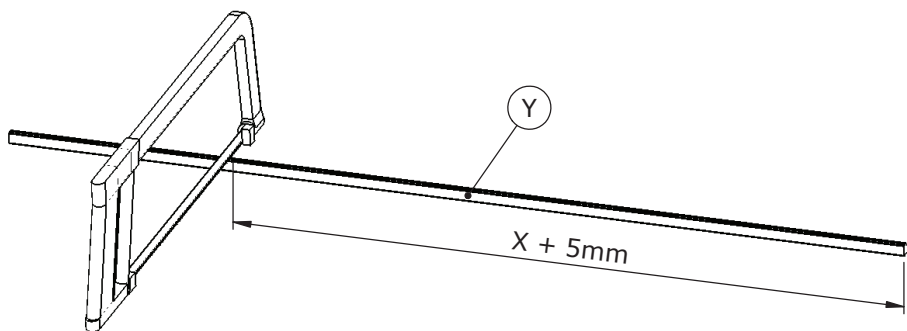
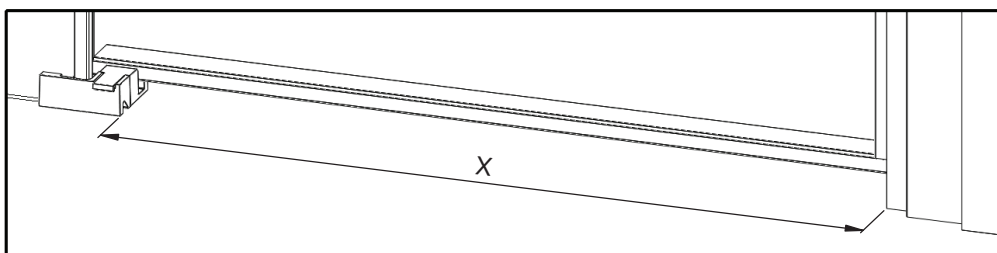
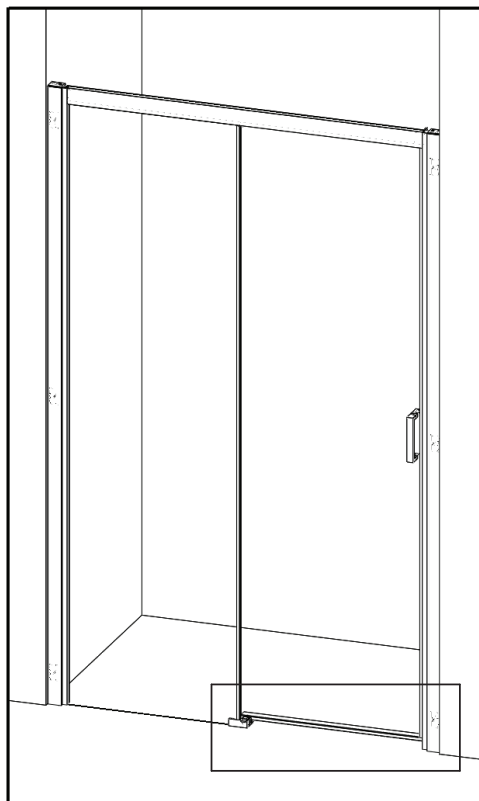

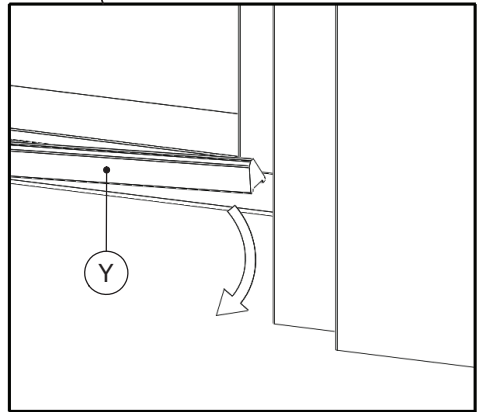
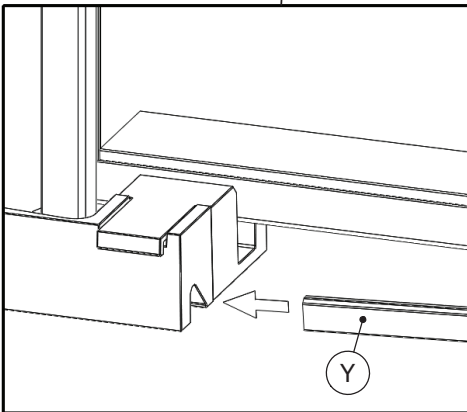
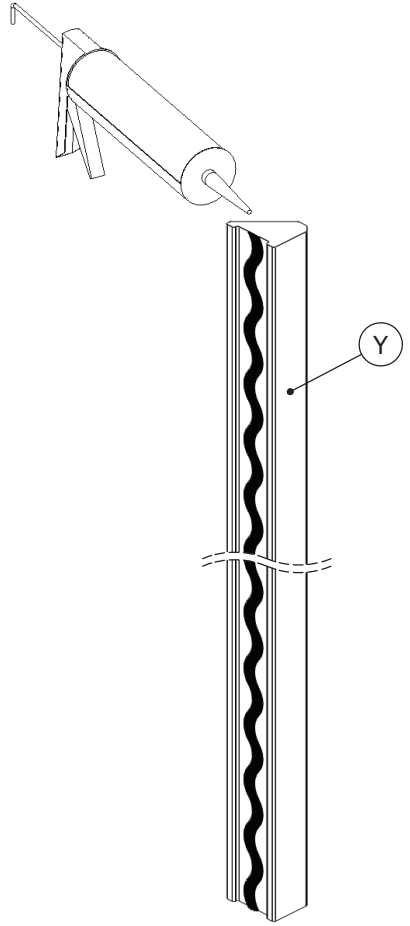
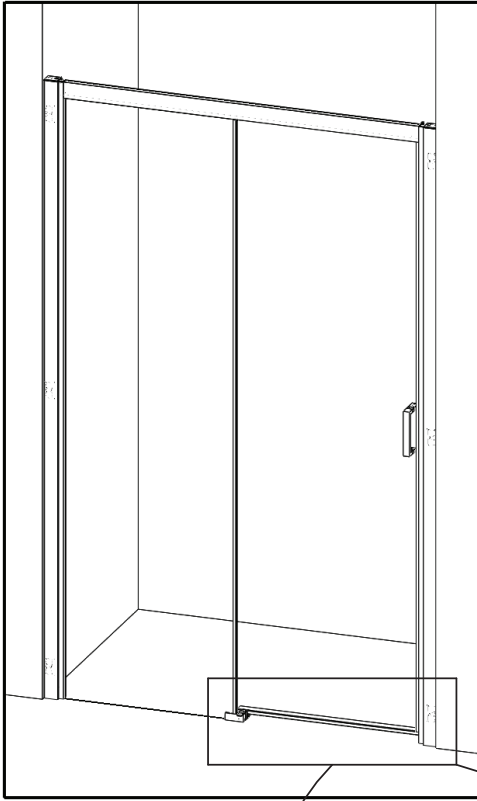

- Ⓛ Cas particulier : Montage par l'intérieur
- ⓄB Special case : Mounting from the inside
- ⓁE Caso especial : Montaje desde el interior
- ⓁI Caso speciale : Montaggio dall'interno
- ⓄNL Speciaal geval : Montage van binnenuit
- Ⓞ Sonderfall : Montage von innen

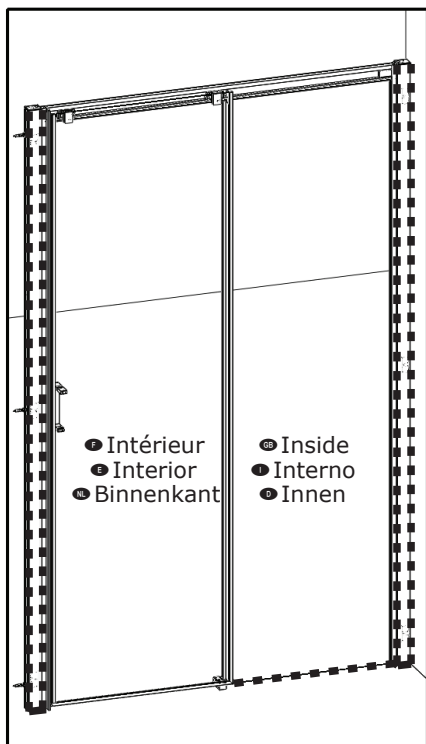

- Ⓛ Détail du siliconage
- ⓄB Detail of the siliconization
- ⓁE Detalle de la siliconización
- ⓁI Dettaglio della siliconizzazione
- ⓄNL Detail van de siliconisatie
- Ⓞ Detail der Silikonisierung

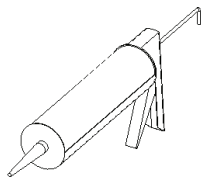
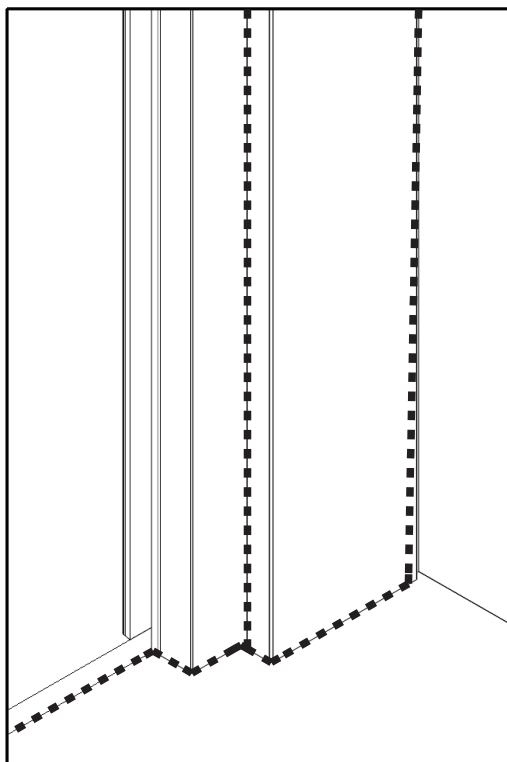

**24H**



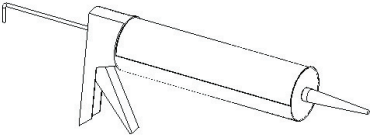



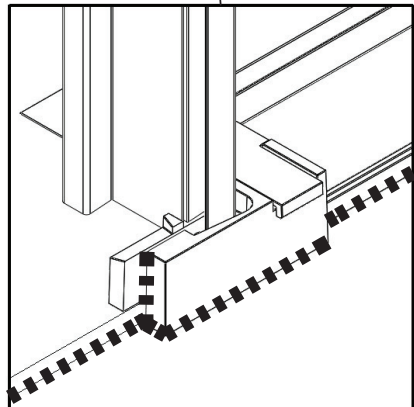
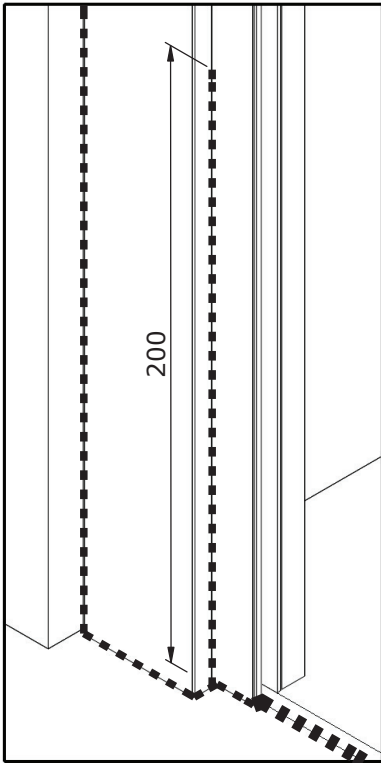
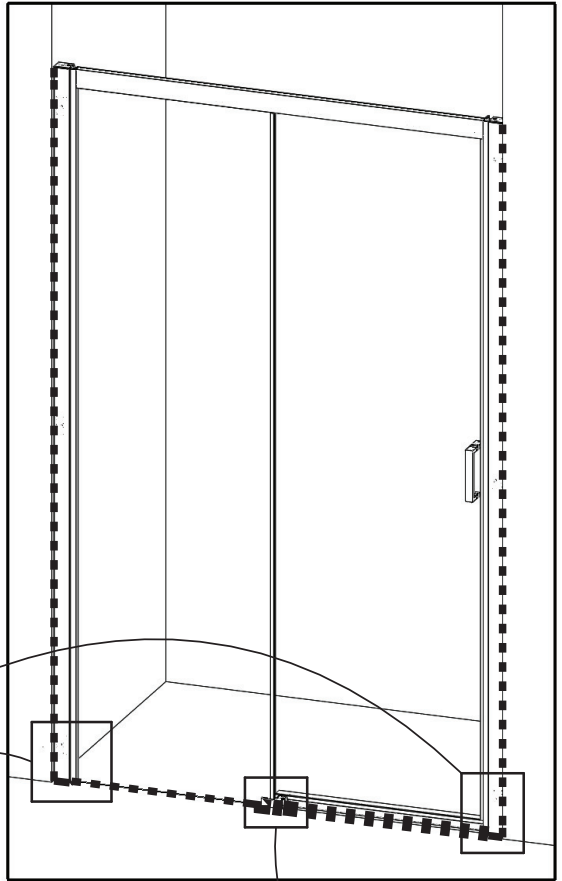

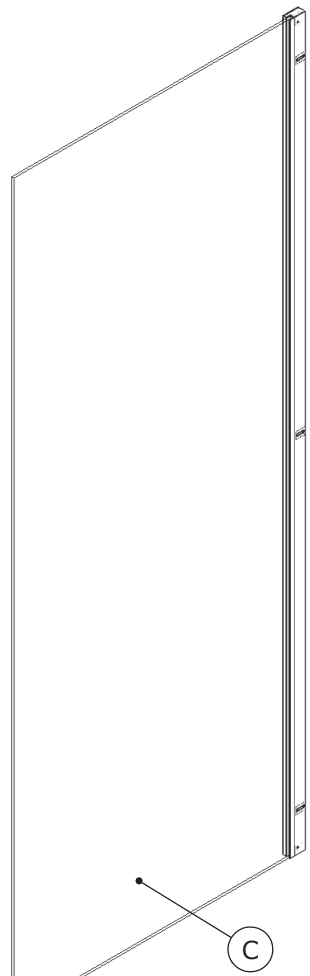
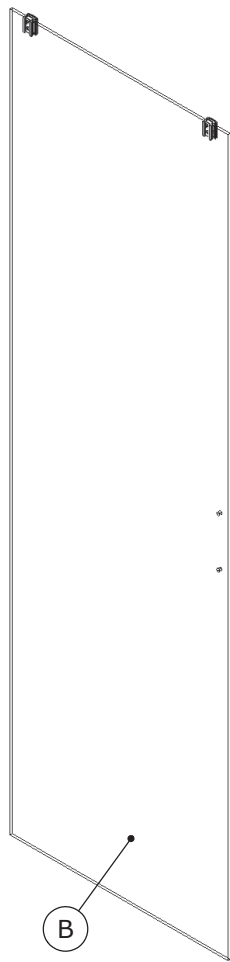
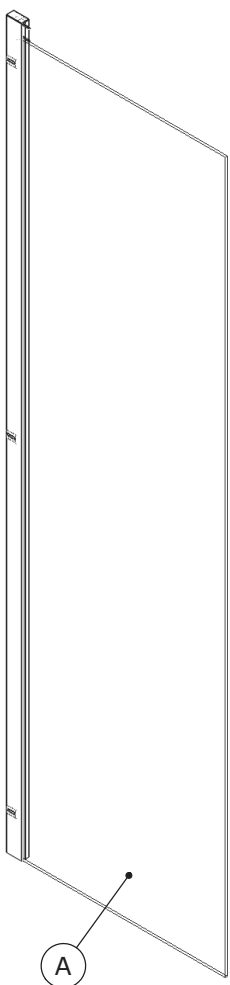

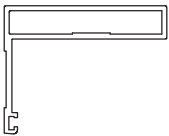
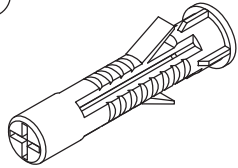
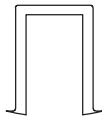
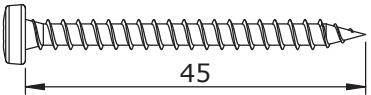
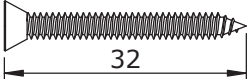
24H

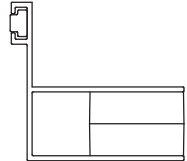
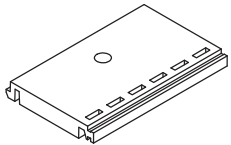

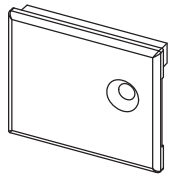
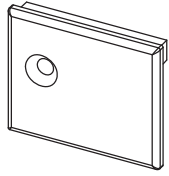
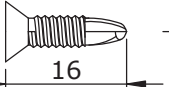
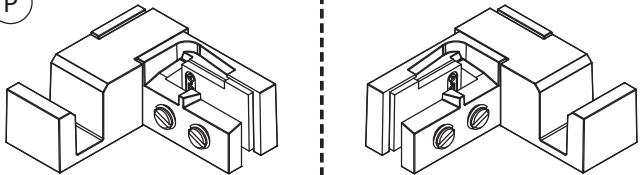
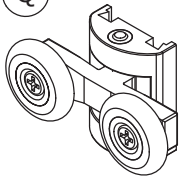
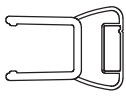

<p>D</p>  <p>x2</p> <p>6242</p>	<p>E</p>  <p>x6</p> <p>CHE02</p>	<p>F</p>  <p>x1</p> <p>JOI301</p>
<p>G</p>  <p>Ø4</p> <p>45</p> <p>x6</p> <p>1=1</p> <p>VIS231</p>	<p>H</p>  <p>Ø3.5</p> <p>32</p> <p>x6</p> <p>1=1</p> <p>VIS255</p>	
<p>I</p>  <p>x1</p> <p>6248E</p>	<p>J</p>  <p>x1</p> <p>6249E</p>	<p>K</p>  <p>x6</p> <p>PPL1197</p>
<p>L</p>  <p>x2</p> <p>6243</p>	<p>M</p>  <p>x1</p> <p>PPL1199</p>	<p>N</p>  <p>x1</p> <p>PPL1200</p>
<p>O</p>  <p>Ø3.5</p> <p>16</p> <p>x2</p> <p>1=1</p> <p>VIS296</p>	<p>P</p>  <p>x1</p> <p>SET212</p> <p>SET213</p>	
<p>Q</p>  <p>x2</p> <p>ROU46</p>	<p>R</p>  <p>x1</p> <p>Lg=1856mm</p> <p>AI193</p>	<p>S</p>  <p>x1</p> <p>Lg=1873mm</p> <p>J889</p>

# DES1420B

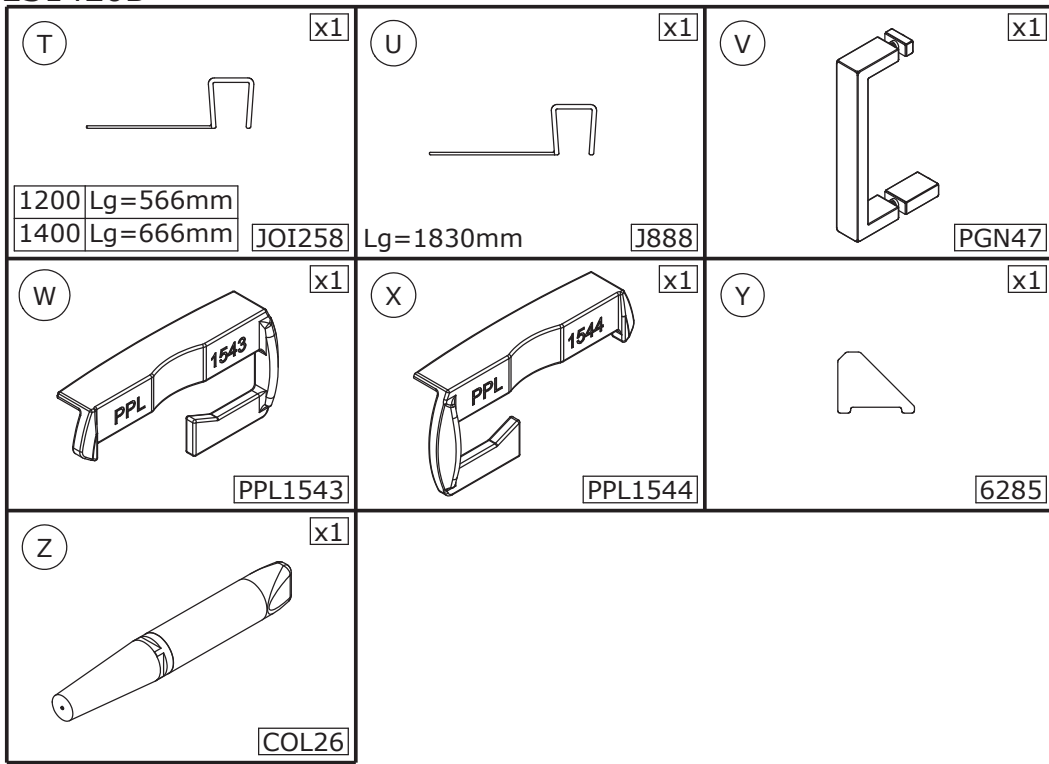

- Fournis avec le fixe ● Supplied with the fixed glass ● Suministrado con cristal fijo
- Fornito con vetro fisso ● Geleverd met vast glas ● Lieferung mit festem Glas

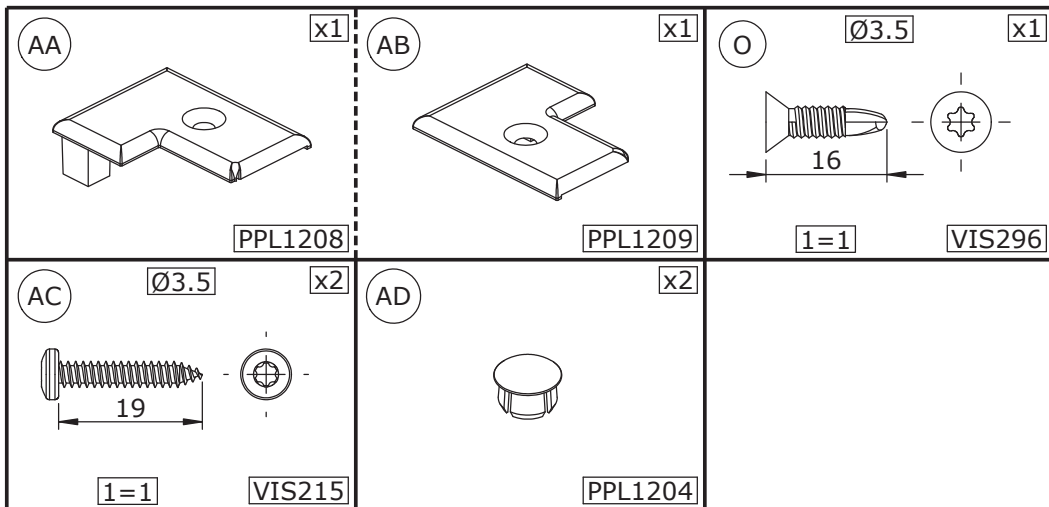

Les quantités données sont les quantités utiles au montage, les sachets fournis contiennent des pièces supplémentaires.  
The quantities given are what are required for the installation. There may be some surplus in the package provide.



**INFO:**

- Montage possible depuis l'intérieur de la douche
  - Can be mounted from inside the shower
- Puede montarse desde el interior de la ducha
  - Può essere montato dall'interno della doccia
  - Kan worden gemonteerd vanuit de douche
- Kann aus dem Inneren der Dusche montiert werden

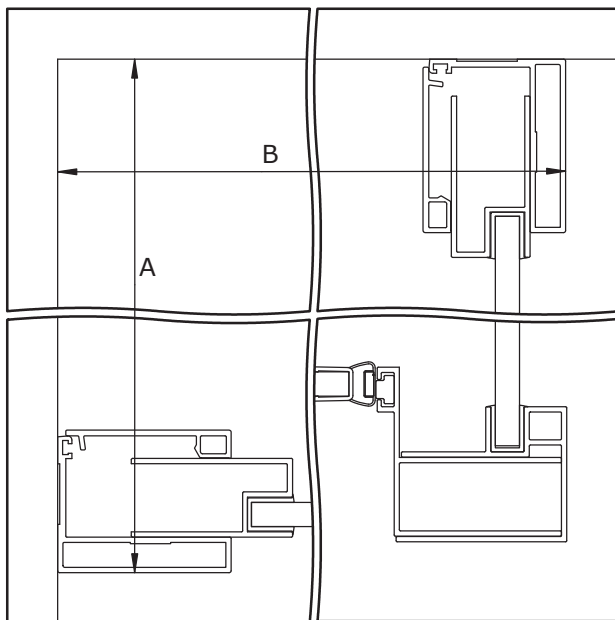
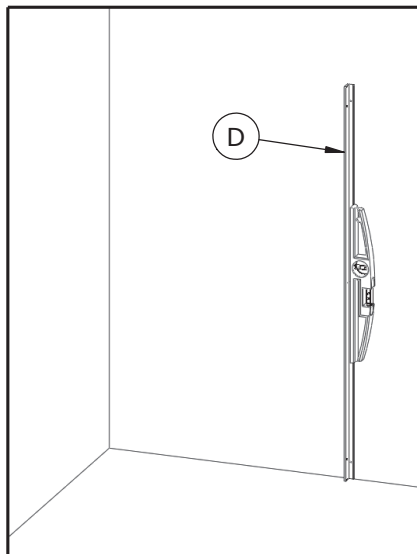

DIMENSIONS	70	80	90	100	120	140
A	675-690	775-790	875-890	975-990		
B					1175-1190	1375-1390

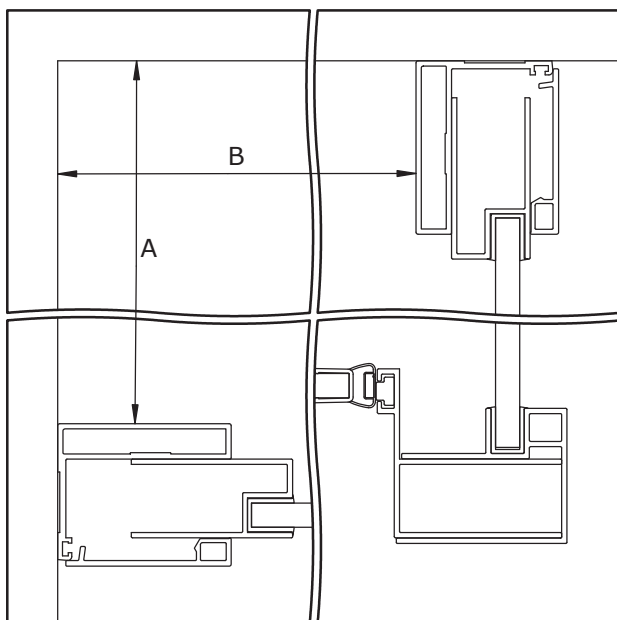
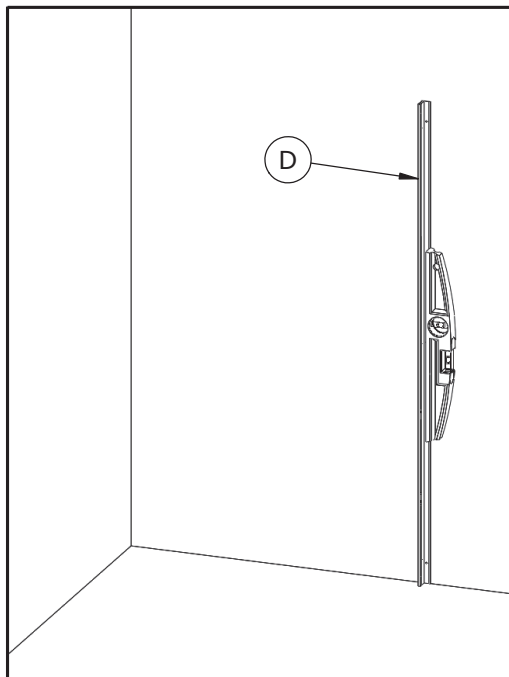

DIMENSIONS	70	80	90	100	120	140
A	638-653	738-753	838-853	938-953		
B					1137-1152	1337-1352

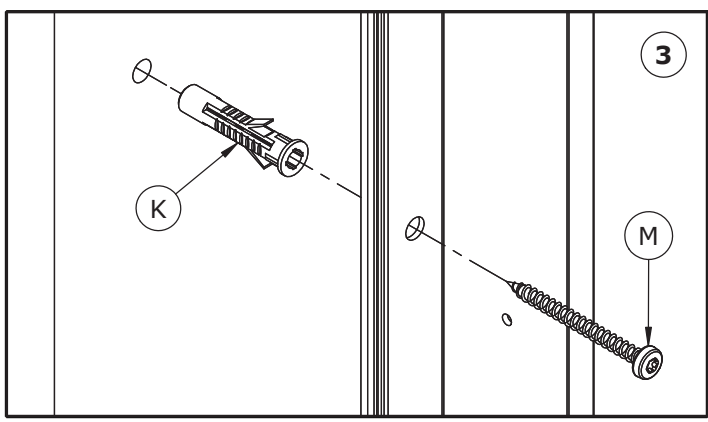
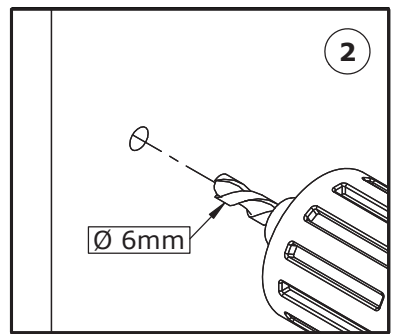
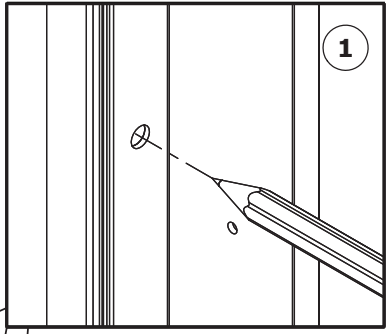
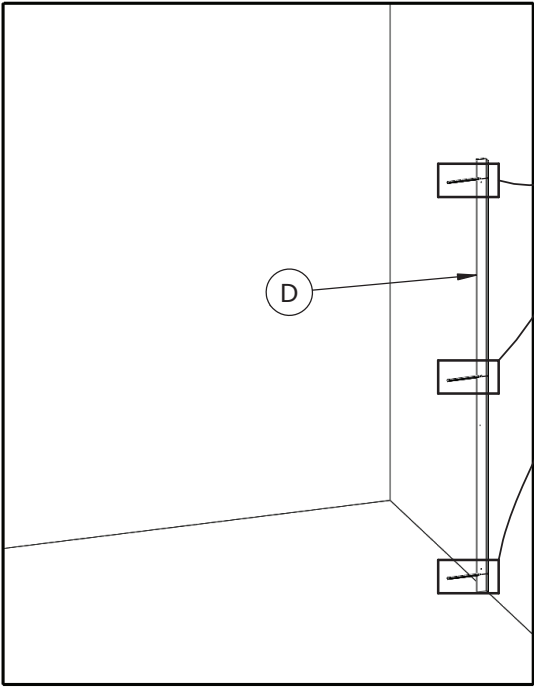

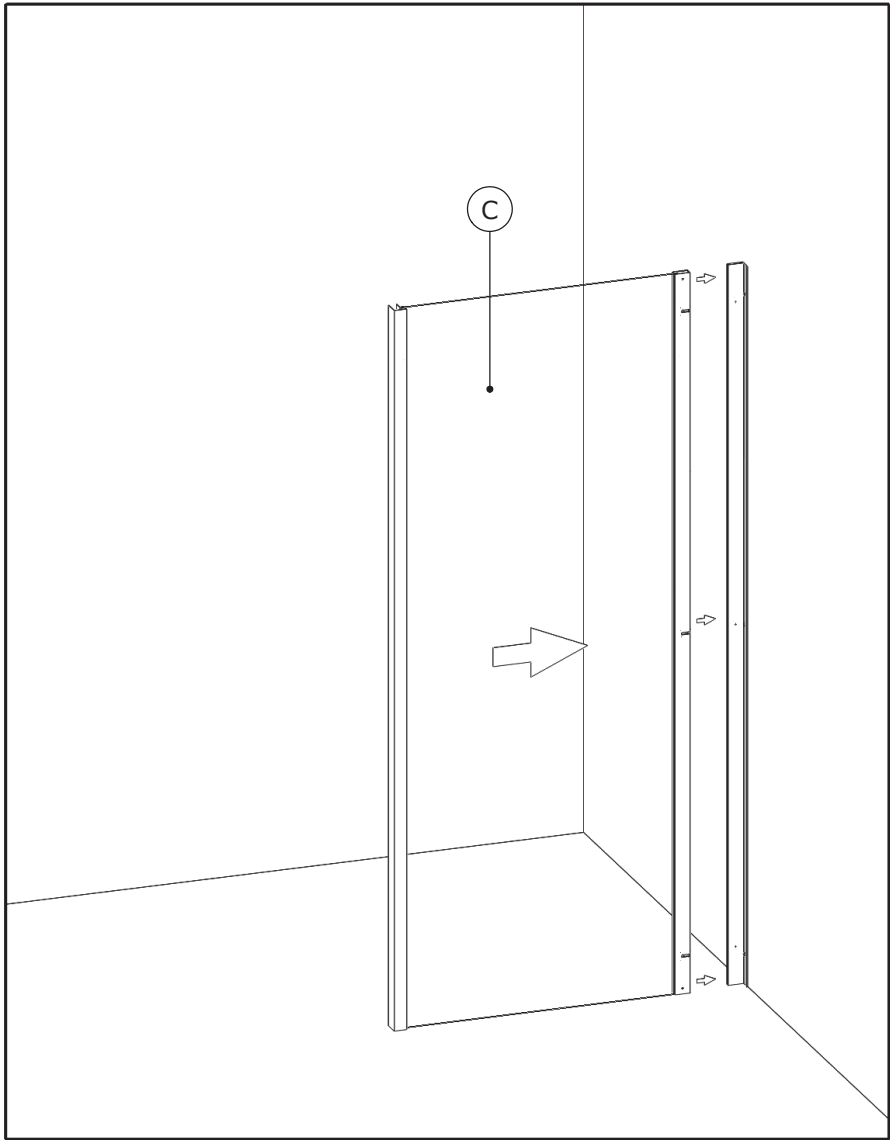

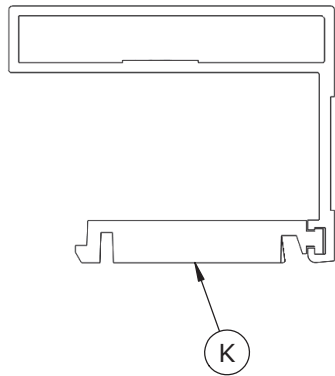
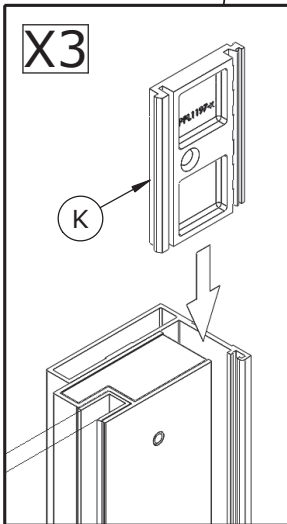
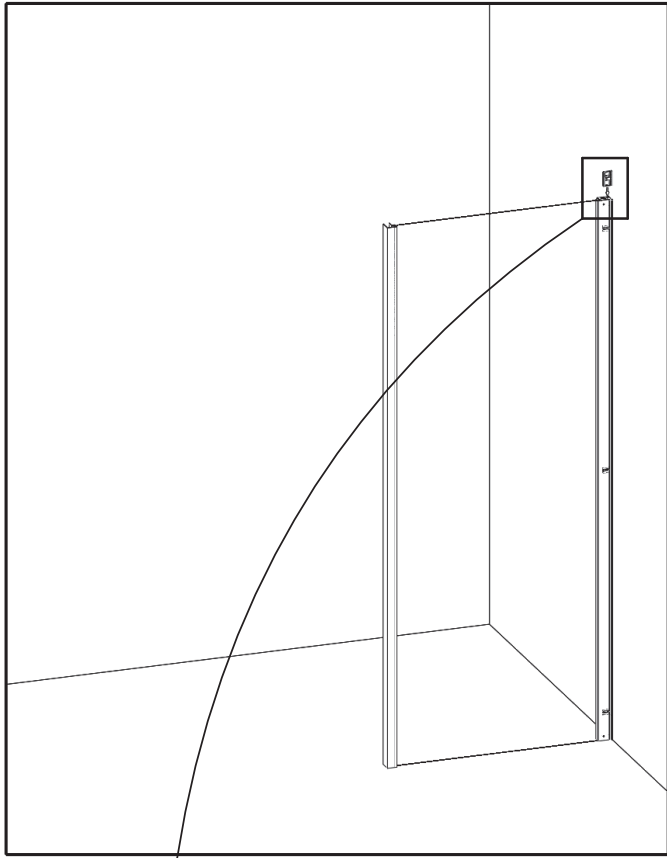

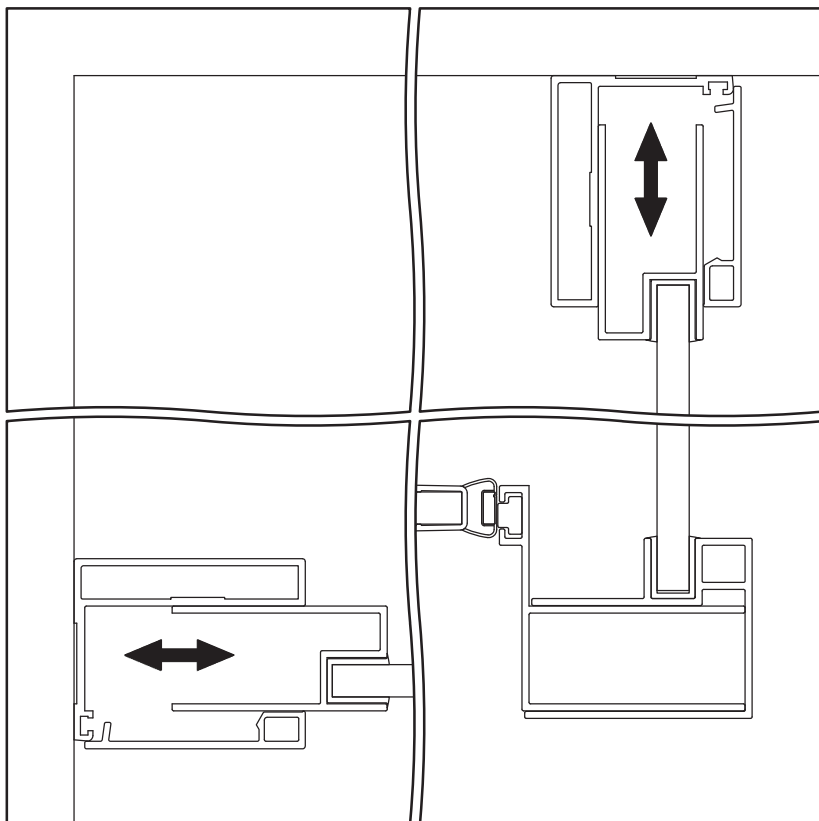
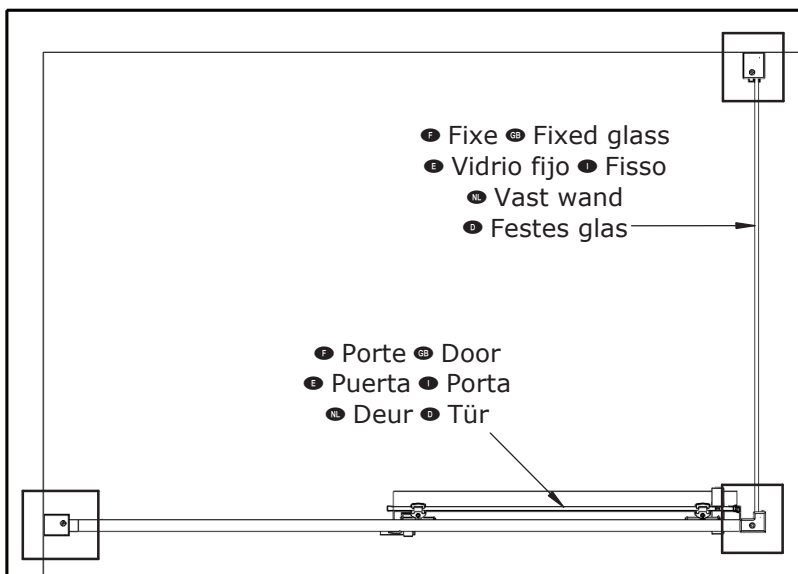

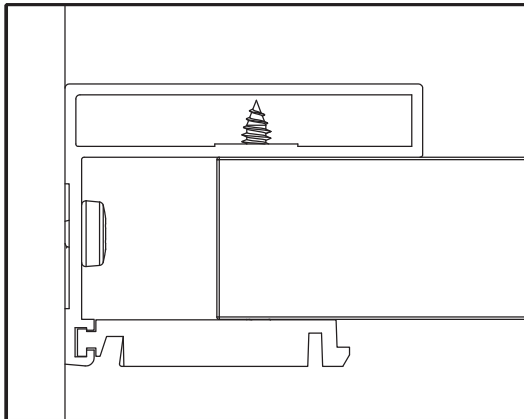
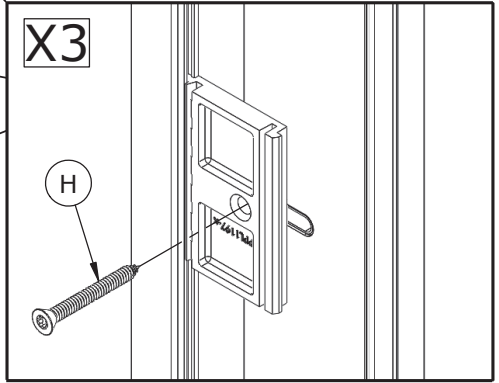
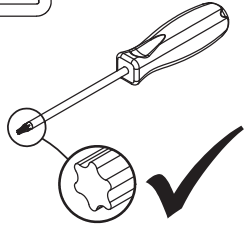
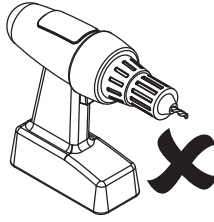
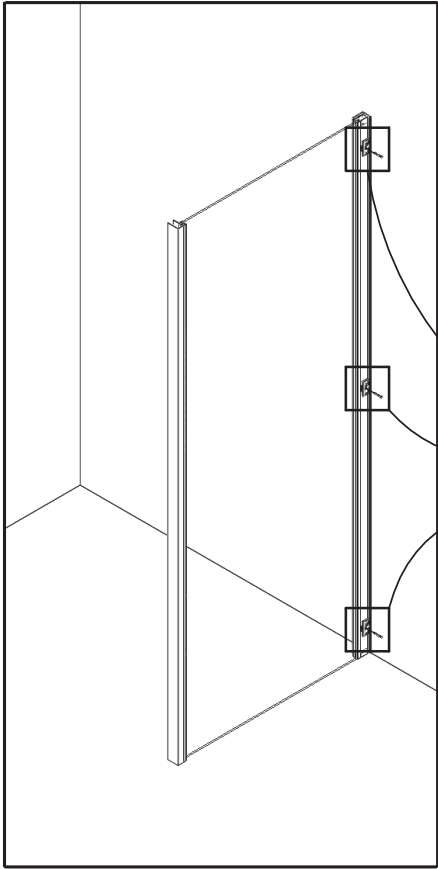

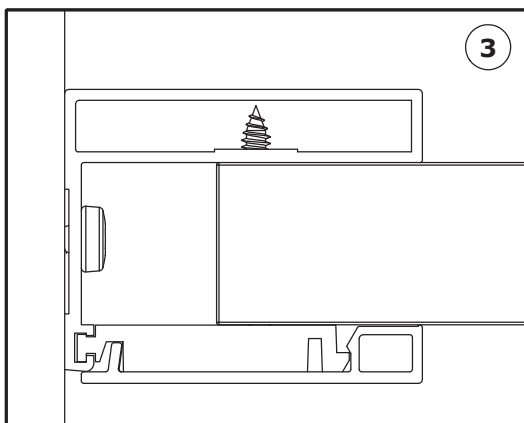
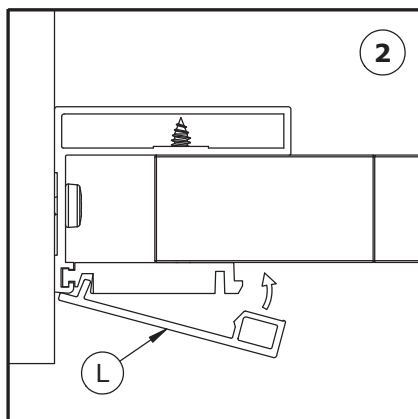
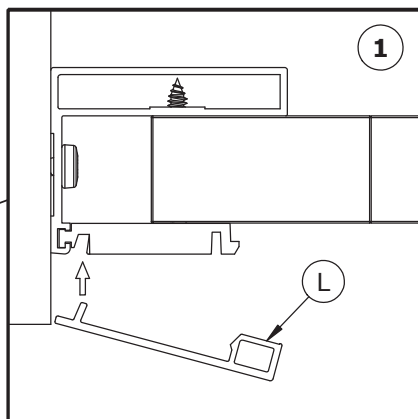
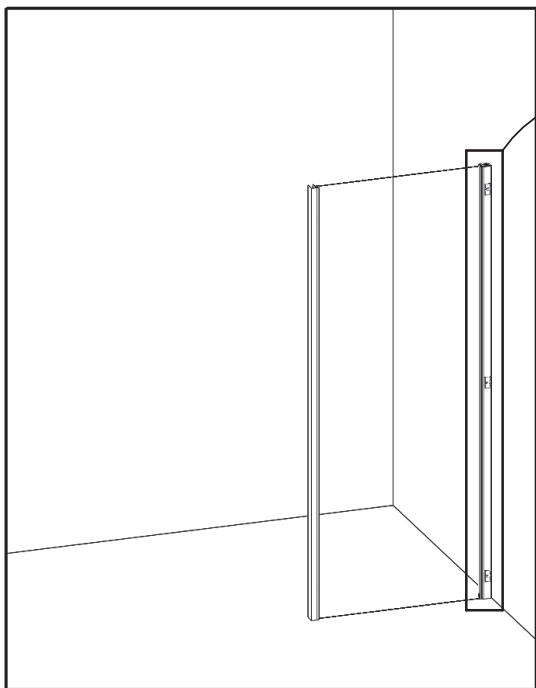



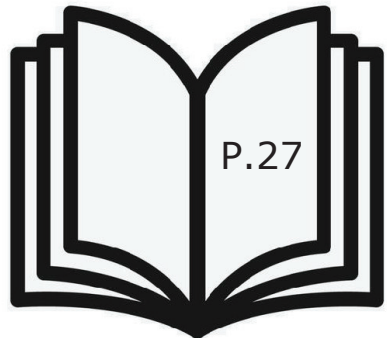
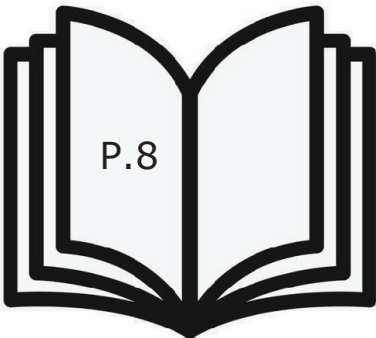
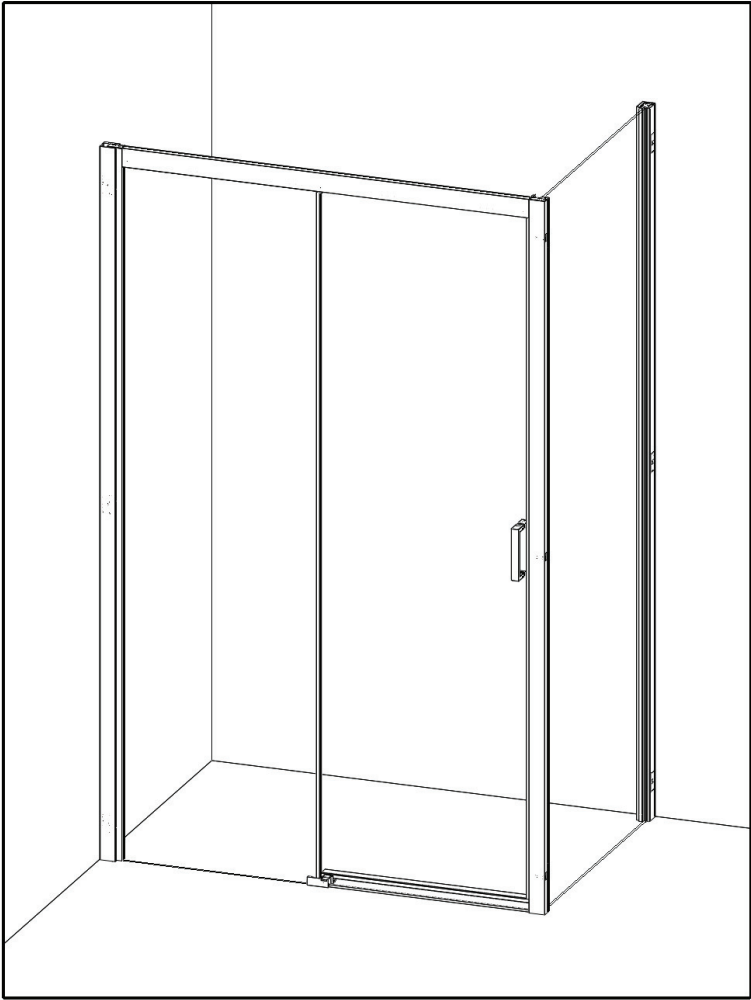

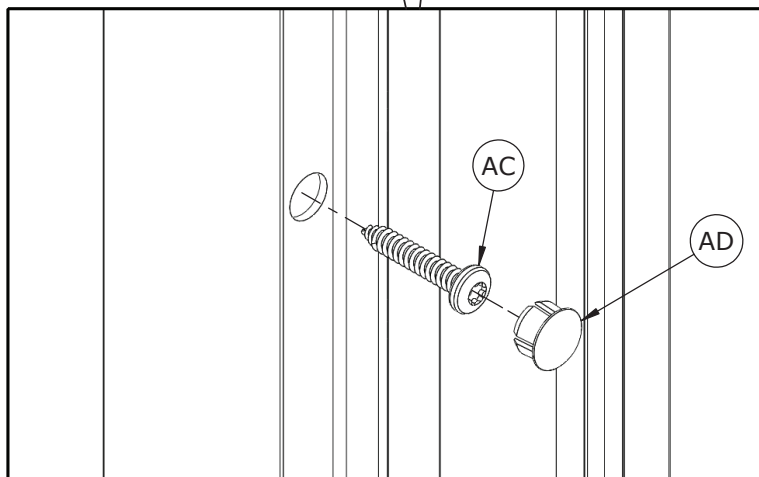
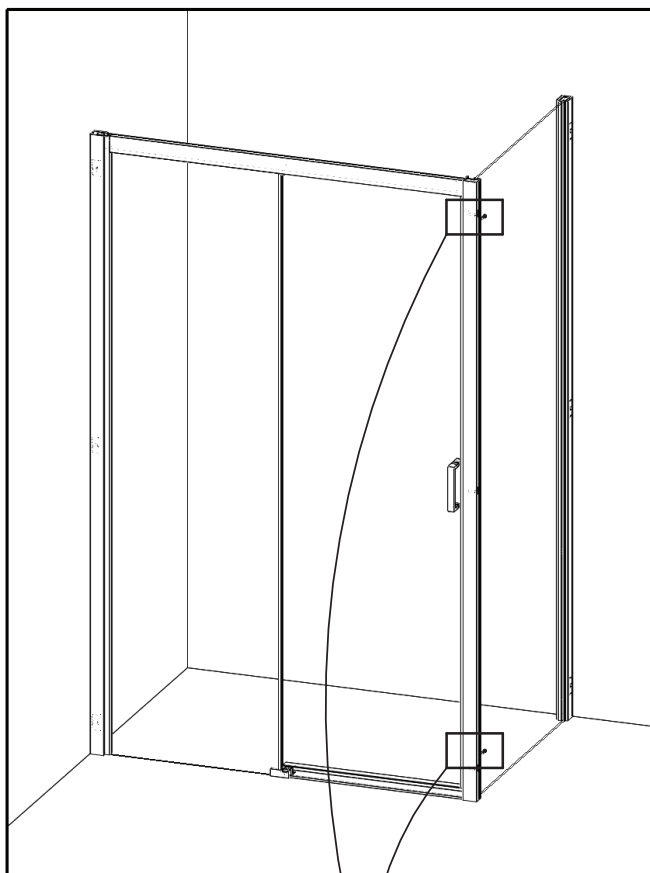

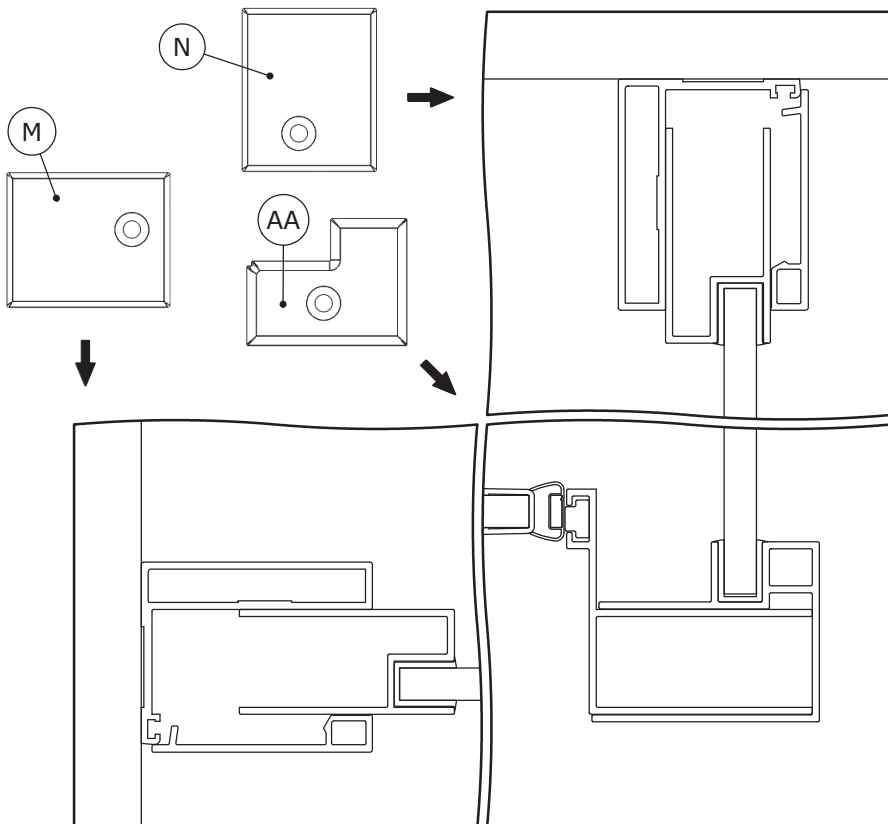
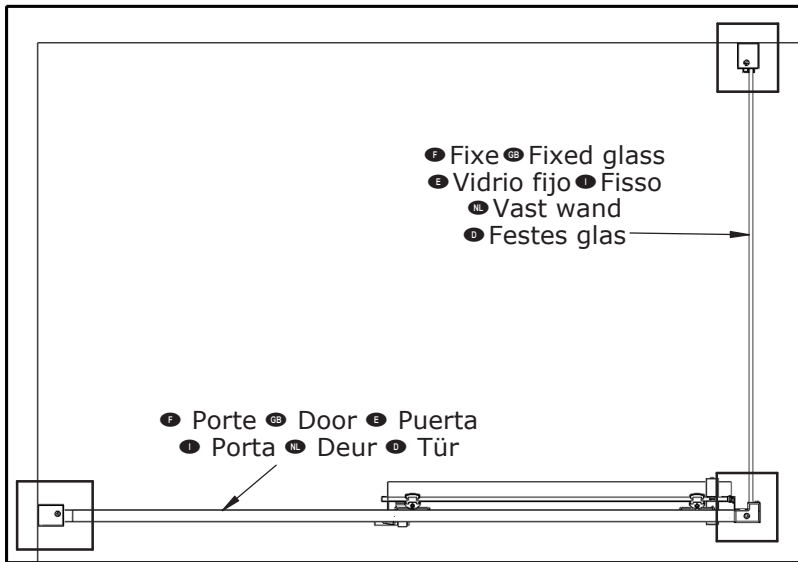

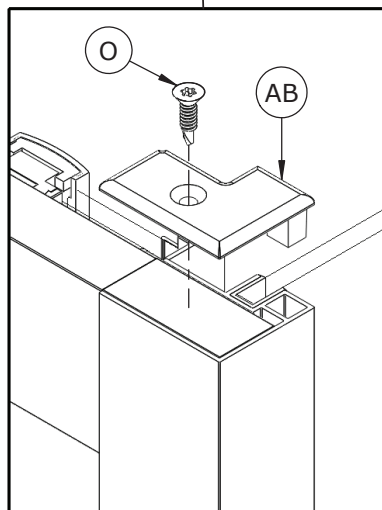
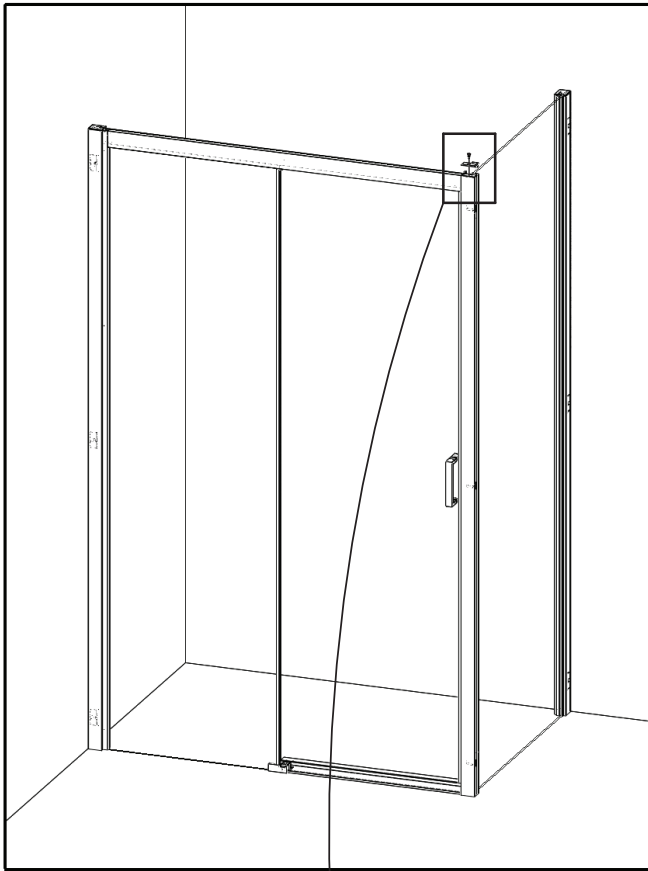

**INFO:**

- Montage possible depuis l'intérieur de la douche
  - Can be mounted from inside the shower
- Puede montarse desde el interior de la ducha
  - Può essere montato dall'interno della doccia
  - Kan worden gemonteerd vanuit de douche
- Kann aus dem Inneren der Dusche montiert werden

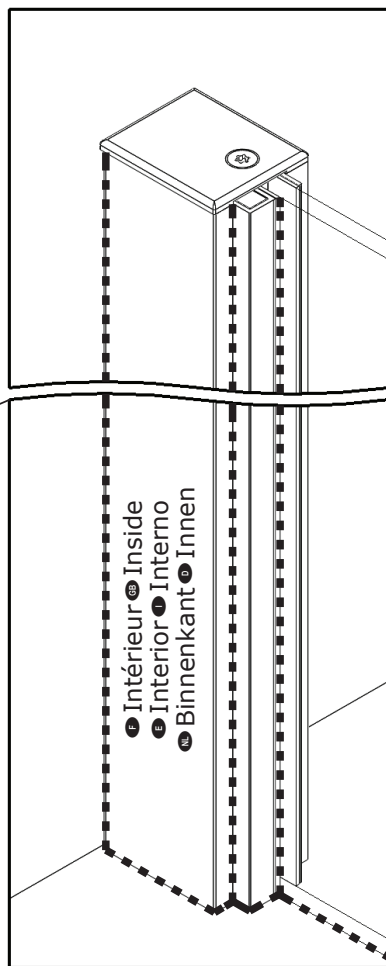
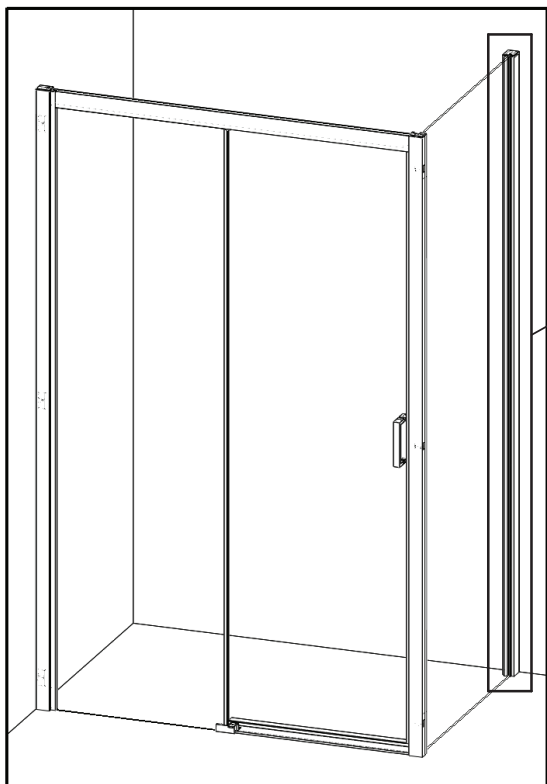
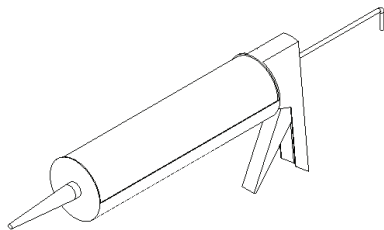
**24H**

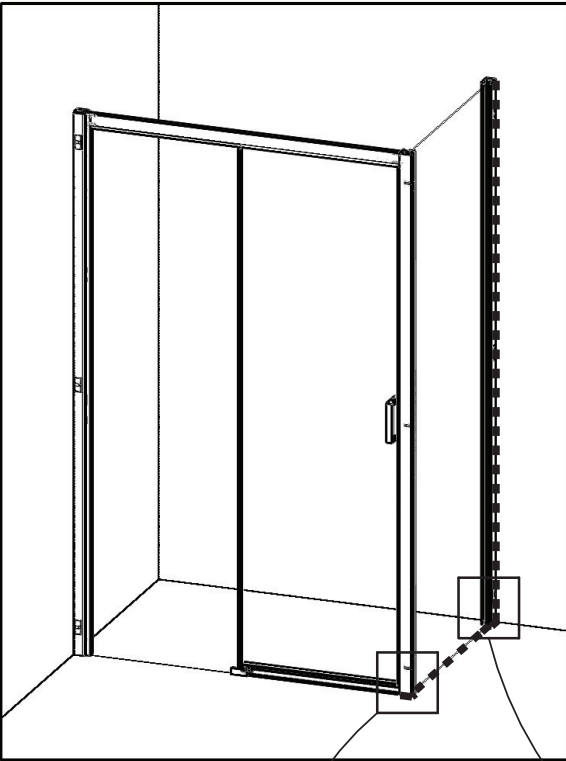

24H

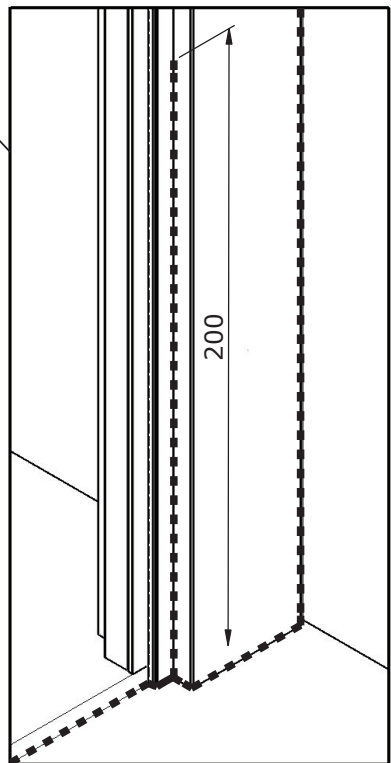
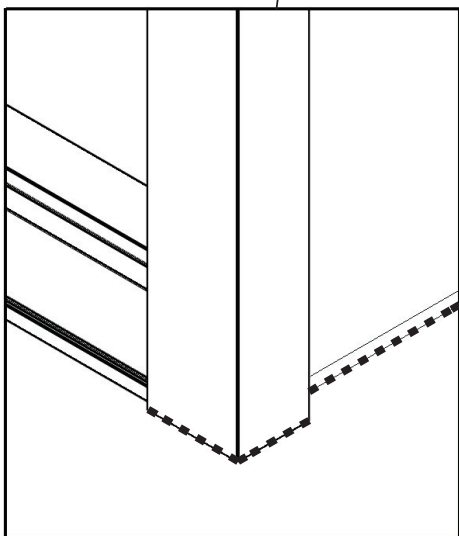
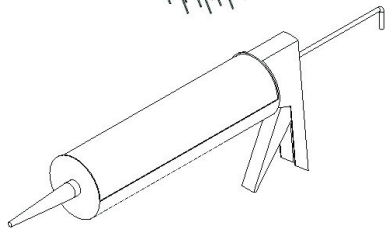



AQUAPRODUCTION, Site industriel, F - 44680 Chéméré

18

**EN 14428**

Paroi de douche, fabriquée en verre de silicate  
sodo-calcique de sécurité trempé thermiquement

Aptitude au nettoyage : réussite

Résistance à l'impact/propriétés de fragmentation : réussite

Durée : réussite



**SAV**  
**SERVICE HELPLINES**  
**ASSISTENZA POST- VENDITA**  
**SERVICIO POSTVENTA**

**FRANCE**

02 40 21 29 45

**UK**

020 8842 0033

**IRELAND**

04697 33102

**DEUTSCHLAND**

+49 (0) 6074 / 30928 0

**ITALIA**

(0382) 6181

**ÖSTEREICH**

+43 1 710 60 70

**SCHWEIZ**

(01) 748 17 44

**ESPANA**

93 544 60 76

**NEDERLAND**

+31 475 487 100

**BELGIË**

+31 475 487 100

**BELGIQUE**

+31 475 487 100

**РОССИЯ**

963 19 40, 773 67 22

**PORTUGAL**

219 112 785