

CUVE MYTHOS MASTERPIECE

Fiche Technique

BXM 110-50



Dimensions: 540 x 450 mm
 Découpe: 500 x 410 mm
 Bassins: 500 x 410 x 200 mm
Caisson: 600 mm

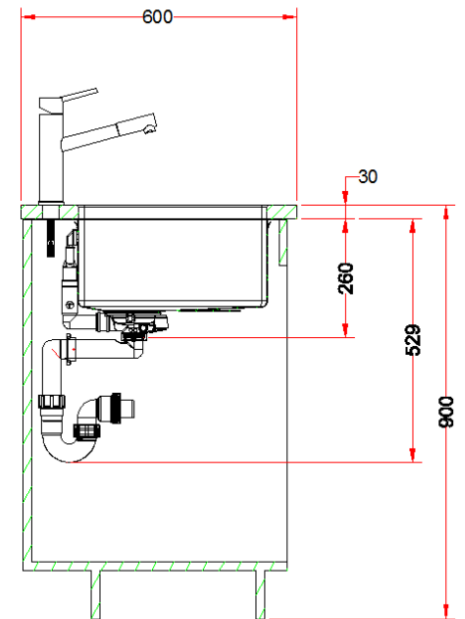
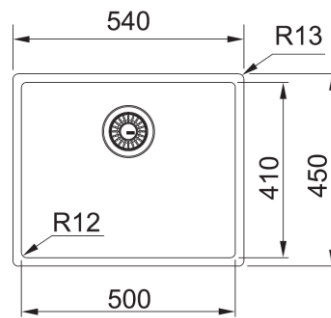

BXM 110 - 50	REFLET D'OR	CUIVRE	ANTHRACITE
Manuel	127.0674.362 7612986 199086	127.0674.363 7612986 199093	127.0672.129 7612986 184464
Automatique	127.0662.540 7612986 117837	127.0662.642 7612986 117844	127.0650.363 7612986 112856



Sous plan
 A encastrer
 A fleur de plan



Garantie à vie sur Inox
 Corrosion et tenue des soudures



Trop-plein exclusif, discret,
 esthétique et facile à nettoyer



Rayon de 12 mm dans les
 angles de la cuve



Vidage comprenant
 bonde Ø 90 mm, siphon et
 tubulure



Pour les vidages
 automatiques : Bonde
 automatique
 Bouton push Inox Ø35mm



Installation à fleur de plan ou à
 encastrer : FastFix : Système de
 fixation par le dessus. Très rapide
 à installer